

# NEUTRO À TERRA

Revista Técnico-Científica

<http://www.neutroaterra.blogspot.com>

*Voltamos à Vossa presença com mais uma edição da nossa revista Neutro-à-Terra.*

*Estamos certos que a qualidade dos artigos publicados nesta edição seguramente que compensarão a curiosidade e o interesse de todos os nossos habituais leitores, que nos privilegiam com o seu interesse desde o início das nossas publicações.*

*Já são 12 anos em que sem interrupções honramos o compromisso que temos convosco.*

*José Beleza Carvalho, Professor Doutor*



**Máquinas e Veículos Elétricos**



**Produção, Transporte e Distribuição Energia**



**Instalações Elétricas**



**Telecomunicações**



**Segurança**



**Gestão de Energia e Eficiência Energética**



**Automação, Gestão Técnica e Domótica**

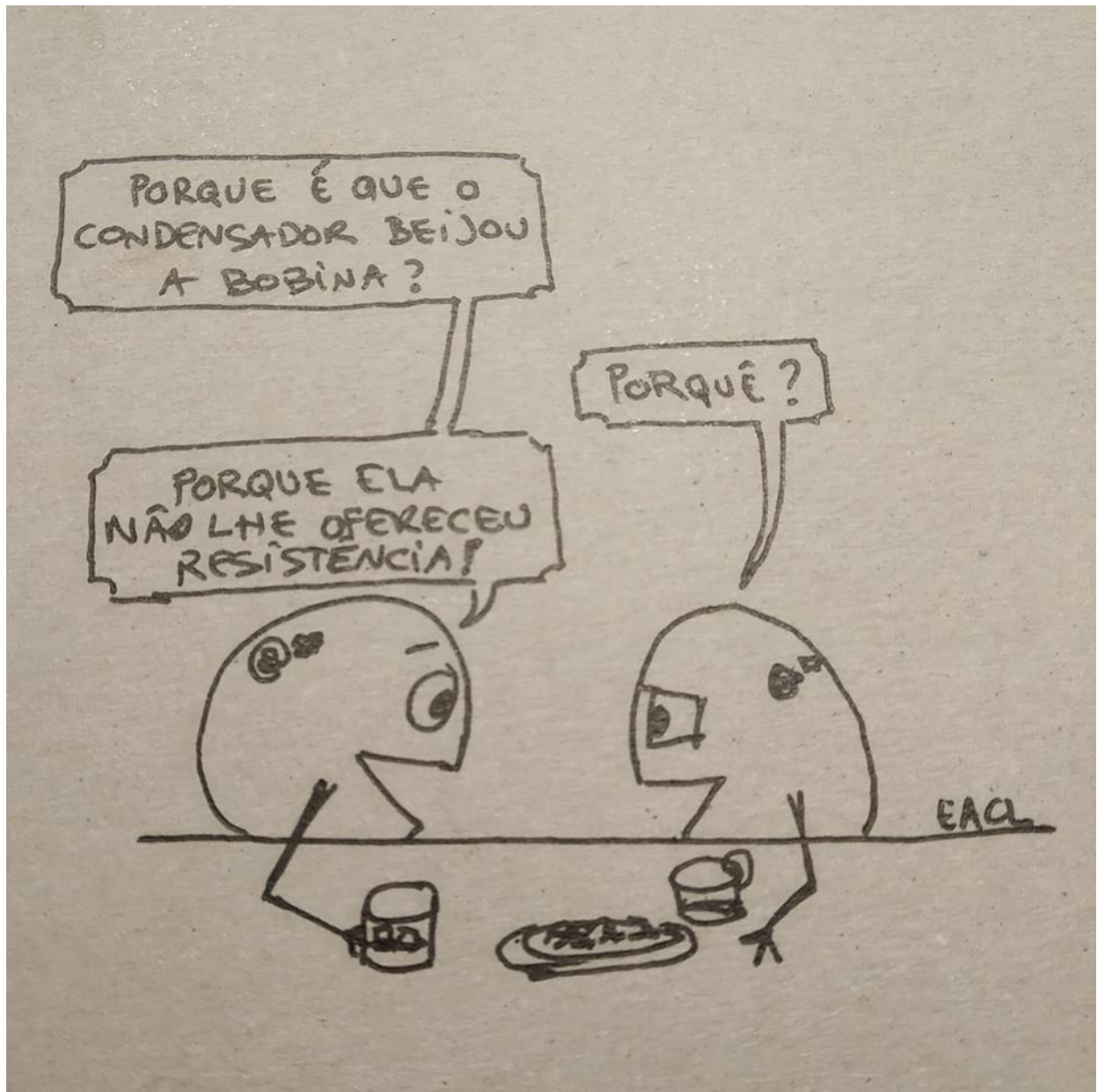

|                                                                                                                                                                       |    |
|-----------------------------------------------------------------------------------------------------------------------------------------------------------------------|----|
| - Editorial                                                                                                                                                           | 5  |
| - Rede Nacional de Transporte<br>Célia Maria dos Santos Carneiro                                                                                                      | 9  |
| - Potencial Energético das Correntes de Maré na Ria de Aveiro<br>João Pedro Pereira da Rocha, J.Dias                                                                  | 25 |
| - Syzing and Analisis of a Photovoltaic System for Self-consumption<br>César M. S. Santos                                                                             | 37 |
| - Solar Power Support of Luxury Boat<br>Aleksandra Wawrzyniak                                                                                                         | 43 |
| - Evolução das Classes de Rendimento de Motores Eléctricos<br>Pedro Miguel Azevedo de Sousa Melo                                                                      | 53 |
| - Experimental analysis of a DC current-controlled variable inductor in a DC-DC converter<br>André P. Mendes; Bruno Baptista; Marina S. Perdigoão; André M. S. Mendes | 61 |
| - A Engenharia ao Serviço da Segurança<br>Alexandre Chamusca                                                                                                          | 71 |
| - Regulamentos técnicos no âmbito das instalações eléctricas<br>António Augusto Araújo Gomes                                                                          | 75 |
| - Autores                                                                                                                                                             |    |

## FICHA TÉCNICA

|               |                                                                                                                                     |
|---------------|-------------------------------------------------------------------------------------------------------------------------------------|
| DIRETOR:      | José António Beleza Carvalho, Doutor                                                                                                |
| SUBDIRETORES: | António Augusto Araújo Gomes, Eng.<br>Roque Filipe Mesquita Brandão, Doutor<br>Sérgio Filipe Carvalho Ramos, Doutor                 |
| PROPRIEDADE:  | Área de Máquinas e Instalações Eléctricas<br>Departamento de Engenharia Electrotécnica<br>Instituto Superior de Engenharia do Porto |
| CONTATOS:     | jbc@isep.ipp.pt ; aag@isep.ipp.pt                                                                                                   |

**Título:** Instalações Elétricas de Baixa Tensão: Dimensionamento e Proteção de Canalizações Elétricas  
**Autor:** António Augusto Araújo Gomes, Henrique Jorge de Jesus Ribeiro da Silva, José António Beleza Carvalho  
**Editora:** Publindústria  
**Data de Edição:** 2017  
**ISBN:** 9789897232046  
**Nº Páginas:** 114  
**Encadernação:** Capa mole

**Sinopse:**

Esta obra pretende ser, acima de tudo, uma ferramenta didática de apoio aos alunos de cursos de engenharia eletrotécnica, bem como a técnicos responsáveis pelo projeto, execução e exploração de instalações elétricas. Pretende ser ainda uma ferramenta prática de estudo e de trabalho, capaz de transmitir conhecimentos técnicos, normativos e regulamentares sobre o dimensionamento e proteção de canalizações elétricas aos diversos agentes eletrotécnicos, tornando-os capazes de, para cada instalação nas quais sejam intervenientes, selecionar o tipo de canalização e o modo de instalação mais adequados, de forma a maximizar a segurança, a fiabilidade e a funcionalidade, assim como os custos de execução e exploração das instalações.

**INSTALAÇÕES ELÉTRICAS DE BAIXA TENSÃO**

Dimensionamento e Proteção de Canalizações Elétricas

**SOBRE O LIVRO**

Esta obra pretende ser, acima de tudo, uma ferramenta didática de apoio aos alunos de cursos de engenharia eletrotécnica, bem como a técnicos responsáveis pelo projeto, execução e exploração de instalações elétricas.

Pretende ser ainda uma ferramenta prática de estudo e de trabalho, capaz de transmitir conhecimentos técnicos, normativos e regulamentares sobre o dimensionamento e proteção de canalizações elétricas aos diversos agentes eletrotécnicos, tornando-os capazes de, para cada instalação nas quais sejam intervenientes, selecionar o tipo de canalização e o modo de instalação mais adequados, de forma a maximizar a segurança, a fiabilidade e a funcionalidade, assim como os custos de execução e exploração das instalações.

**SOBRE OS AUTORES**

**António Augusto Araújo Gomes**

Bacharel em Engenharia Eletrotécnica – Sistemas de Energia pelo Instituto Superior de Engenharia do Porto – licenciado em Eletricidade (que inclui) em Engenharia Eletrotécnica e Computadores pela Faculdade de Engenharia da Universidade do Porto. Professor adjunto no Departamento de Engenharia Eletrotécnica do Instituto Superior de Engenharia do Porto desde 1999. Coordenador do Orçamento na CEFAEPUS – Engenharia de Segurança, entre 1997 e 1999. Sócio da empresa Realto à Terra – Gabinete de Engenharia, Lda (2002 a 2006). Prestação de serviços de formação e supervisão de pessoal e apoio consultivo no âmbito das instalações elétricas, telecomunicações, segurança, gestão de energia, eficiência energética, a diversas entidades nomeadamente: NORVIA – Consultores de Engenharia, S.A.; Schmalz – Engenharia e Serviços, Lda; ENERPO – Consultores de Engenharia, Lda; EG – Instituto de Substância e Qualidade, Químicas – Fabrica de Quadros Elétricos, S.A.; EP – Instituto Eletrotécnico Português; CEMETEC – Centro de Energia e Tecnologia; ANACOM – Autoridade Nacional das Telecomunicações; IET – Instituto para o Desenvolvimento Tecnológico; ENX – Agência de Energia Entre Douro e Vouga.

**Henrique Jorge de Jesus Ribeiro da Silva**

Licenciado em Engenharia Eletrotécnica, ramo de Produção, Transporte e Distribuição de energia, pela Faculdade de Engenharia da Universidade do Porto e Mestre (gr. Bolonha) em Engenharia Industrial, pela Escola de Engenharia da Universidade do Minho. Professor Adjunto no Departamento de Engenharia Eletrotécnica do Instituto Superior de Engenharia do Porto.

**José António Beleza Carvalho**

Bacharel em Engenharia Eletrotécnica pelo Instituto Superior de Engenharia do Porto; Mestre e Doutor em Engenharia Eletrotécnica na especialidade de sistemas de energia pela Faculdade de Engenharia da Universidade do Porto. Professor Coordenador no Departamento de Engenharia Eletrotécnica do Instituto Superior de Engenharia do Porto, desempenhando as funções de Diretor do Departamento, vogal e direção de Escola Tecnológica de Vals de Camarã como investigador do Instituto Politécnico do Porto. Autor de vários artigos publicados em conferências nacionais e internacionais, diretor de revista neutro-ôter e integrou vários júris de provas públicas de doutoramento e para a câmara do ensino superior.

**ENGEBOOK**

Família Empresarial  
 de Instalações Elétricas

Com o apoio de **Life to On** **Schneider Electric** **Weidmüller**



Estimados leitores

Um pouco mais tarde que o habitual, pois os afazeres dos responsáveis pela edição da revista no fim de um ano letivo numa escola prestigiada de Engenharia são sempre muitos e complicados, voltamos à Vossa presença com mais uma edição da nossa revista Neutro-à-Terra. Estamos certos que a qualidade dos artigos publicados nesta edição seguramente que compensarão a curiosidade e o interesse de todos os nossos habituais leitores, que nos privilegiam com o seu interesse desde o início das nossas publicações. Já são 12 anos em que sem interrupções honramos o compromisso que temos convosco.

Numa revista focada nas áreas de especialização da Engenharia Eletrotécnica, tem sido falha dos editores a não apresentação de um artigo técnico-científico que apresente de uma forma clara e suficientemente desenvolvida o funcionamento de um Sistema Elétrico de Energia, ou seja, a produção, o transporte e distribuição de energia elétrica que todos usufruímos diariamente nas nossas atividades. Esta falta é compensada nesta edição da nossa revista, com apresentação de um artigo muito interessante sobre a Rede Nacional de Transporte e o funcionamento do Sistema Elétrico de Energia Português, da autoria da Engenheira Célia Carneiro, Mestre em Engenharia Eletrotécnica pelo ISEP, e operadora responsável no Centro de Operações da Rede de Muito Alta Tensão, localizado em Vermoim.

Os trabalhos de investigação desenvolvidos no ISEP, fundamentalmente no âmbito do desenvolvimento de Dissertações de Mestrado, permitem a realização de artigos científicos de elevada qualidade. Nesta edição publica-se dois artigos científicos em Inglês, *“Syzing and Analisis of a Photovoltaic System for Self-Consumption”* e *“Solar Power Support Of Luxury Boat”*, mantendo assim o compromisso que temos em regularmente publicar artigos científicos em língua Inglesa, fundamentalmente destinados aos nossos leitores dos países Anglo-Saxónicos. Ainda neste âmbito, merece particular destaque um artigo científico publicado conjuntamente por 2 investigadores da WEG e do Departamento de Engenharia Eletrotécnica da Universidade de Coimbra, *“Experimental Analysis of a DC Current-Controlled Variable Inductor in a DC-DC Converter”*.

No âmbito das Máquinas Elétricas, como tem sido habitual nas nossas recentes edições, publica-se mais um interessante artigo da autoria do Eng<sup>o</sup> Pedro Melo, neste caso sobre a *“Evolução das Classes de Rendimento de Motores Elétricos”*, onde se apresenta uma síntese da evolução das classes de rendimento de motores elétricos de alcance internacional. Começando pelo acordo CE/CEMEP, no contexto europeu, referindo depois as sucessivas normas internacionais CEI, as quais traduzem a evolução da classificação IE.

Nesta edição da nossa revista merecem ainda destaque alguns artigos de elevado valor técnico e científico. Apresenta-se um artigo sobre *“Potencial Energético das Correntes de Maré na Ria de Aveiro”*, onde é feita uma abordagem ao aproveitamento da energia cinética existente no movimento de água induzido pela propagação das marés na produção de energia elétrica. Apresenta-se também um artigo sobre *“A Engenharia ao Serviço da Segurança”*, onde são abordadas as exigências crescentes que se fazem sentir nesta crescente área de negócio. Finalmente, mas não de menor importância, apresenta-se um artigo sobre *“Regulamentos Técnicos no Âmbito das Instalações Elétricas”*, da autoria do Eng<sup>o</sup> António Gomes, um especialista que tem vindo aprofundar este assunto nas suas atividades profissionais e também em publicações que tem efetuado sobre o assunto.

Fazendo votos que esta 23<sup>a</sup> edição da nossa revista *“Neutro à Terra”* vá novamente ao encontro das expectativas dos nossos leitores, estes semestre um pouco mais tarde que o habitual, mas com artigos de elevado valor técnico e científico, apresento os meus cordiais cumprimentos.

Porto, julho de 2019

José António Beleza Carvalho

**Título:** Instalações Elétricas de Baixa Tensão - Aparelhagem de Proteção, Comando e Seccionamento  
**Autor:** António Augusto Araújo Gomes, Sérgio Filipe Carvalho Ramos, André Fernando Ribeiro de Sá  
**Editora:** Publindústria  
**Data de Edição:** Engebook  
**ISBN:** 9789898927187  
**Nº Páginas:** 226  
**Encadernação:** Capa mole

**Sinopse:**

A obra Instalações Elétricas de Baixa Tensão - Aparelhagem de Proteção, Comando e Seccionamento pretende ser, acima de tudo, uma ferramenta didática de apoio aos alunos de cursos de Engenharia Eletrotécnica, bem como a Técnicos Responsáveis pelo projeto, execução e exploração de instalações elétricas. Pretende ser, ainda, uma ferramenta prática de estudo e de trabalho, capaz de transmitir conhecimentos técnicos, tecnológicos, normativos e regulamentares sobre a aparelhagem de proteção, comando e seccionamento de baixa tensão, aos diversos agentes eletrotécnicos, tornando-os capazes de, para cada instalação na qual sejam intervenientes, maximizar a segurança, a fiabilidade e a funcionalidade, assim como reduzir os custos de execução e exploração das instalações.

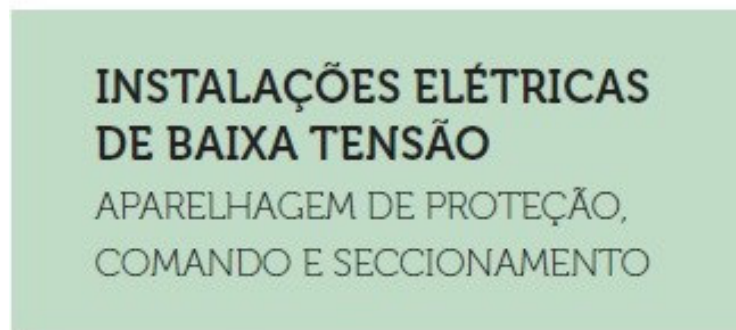

ENGEBOOK **ELEOTECNIA**

António Gomes  
 Sérgio Ramos  
 André Sá



Blog:

[www.neutroaterra.blogspot.com](http://www.neutroaterra.blogspot.com)

Histórico de visualizações

**34 401**

| Entrada        | Visualizações de páginas |
|----------------|--------------------------|
| Portugal       | 25725                    |
| Estados Unidos | 2950                     |
| Brasil         | 1956                     |
| Alemanha       | 531                      |
| França         | 445                      |
| Rússia         | 432                      |
| Angola         | 242                      |
| Reino Unido    | 205                      |
| Ucrânia        | 190                      |
| Espanha        | 137                      |

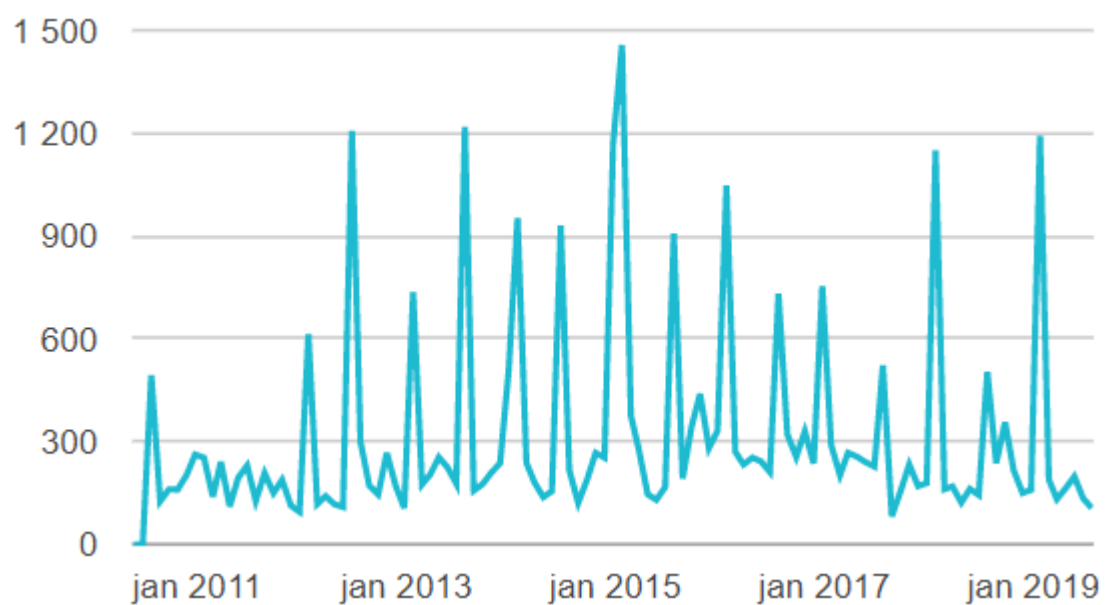

## SOLAR POWER SUPPORT OF LUXURY BOAT

### ABSTRACT

*This document contains project of solar power support for luxury boat. This project is design of electrical installation of the boat with solar panel system as an additional energy source what in case of an emergency it is possible to supply loads necessary for communication and safety. Electric propulsion system allows better maneuvering at low speed. This work presents design of electrical installation of the base and of the solar part of the system with all the necessary elements. Simulation of solar design and power analysis of solar part of the system are presented, what provides with good picture of its influence on the system. Obtained results are promising and can potentially be extended to bigger systems. This kind of solution highly increases reliability of the system.*

*Index Terms— PV system, solar power support, boat propulsion system, hybrid system, electrical installation design, power analysis*

### I. INTRODUCTION

EFFICIENCY, availability and popularity of solar panels keep growing, and ecological tendencies in our community are getting stronger than ever, it is important to find solutions of microgrids equipped with solar photovoltaics as a main source of electrical power. Microgrids are small scale supply network designed for supplying electrical and heat loads, where generators or renewable energy sources to generate power at distribution voltage. From operational point of view the energy sources in microgrids must maintain the specified power quality and energy output. [1] Solar modules are widely used for electrification and in off-grid housing. It is also becoming popular among the touristic vessels and small boat to use solar panels as an additional energy source.

There are many types of solar panels available on the market.

They differ in materials, efficiency, costs, parameters of cell and production method. Some of them are: Silicon solar cells, Amorphous silicon solar cells, III-V Semiconductor Solar Cells, Perovskite and Perovskite/silicon tan-dem cell.

There are several ways of placing solar panels on the surface of the boat. Most popular approach is to place solar panels on the roof of the boat, which is usually the biggest area available for placement of solar panels. In many cases designs of the boats has solar panels on the deck and have wings or sail with solar panels. In this way it is possible to place relatively high area of solar panels without limiting space available for people and without big interference of outer design of the boat. This solution is very common while remodeling of boat to operation supported with solar power. Solar radiation is higher above waterline than below it, but solar energy penetrates the water and if it is properly managed it can offer a significant energy resource.

Effect of water absorption on solar spectrum varies with depth and water clarity. It is possible to observe that in spectrum above 700nm spectral irradiance is highly decreasing on all depths and on the depth of 2 meters is nearly entirely absorbed. What is more between 400nm and 650nm of wavelength the absorption level is the lowest. Close to the water surface interruption of spectral irradiance is small. It is also possible to see that water absorption effect removes the ultraviolet and infrared portions of solar spectrum.

Depending on construction and design of the boat there are various configuration of the main power circuits available. There are many systems designs what allows to choose appropriate solution for every application. Diesel-electric propulsion system has many advantages. The benefits of this solution are lower fuel consumption and emissions due to the ability of optimization of loading of diesel gensets. Better hydrodynamics efficiency of the propeller. Multiple engine redundancy gives this solution high reliability.

An-other advantage of diesel-electric propulsion is lower noise and reduced vibrations. It also gives more flexibility in location of gensets and propulsors. Main components of a diesel-electric propulsion plant are diesel generators, switchboards, transformers, frequency converters/variable speed drives, electric propulsion motors and propellers.

There are many available options of power system design for boats. Systems can be divided for AC and DC systems. One of typical AC systems is onboard power plant where main generator is connected to the main switchboard. Two propulsions are connected to the main switchboard via three phase transformers and rectifying units. System can be divided in two to increase its reliability. Then another option of AC network is a single screw system. It fulfils high redundancy requirements, but it requires high propulsion power and high efficiencies motors. Other solution for the AC system is double screw system with multiple volt-age levels and different currents. Another solution is onboard DC grid with multidrive approach where power from generators are converted to DC current and connected to main DC switchboard.

There are many benefits of the onboard DC grid. Vessel layout is more functional through more flexible placement of electrical component. Improved dynamic response and maneuverability, and up to 20 per-cent fuel savings. Another onboard DC grid has distributed approach. In this system propulsion systems are connected to separate DC buses. With a distributed approach, the various converters can be placed where it suits the vessel operation or design best. This allows a new level of freedom in designing the electrical power system, increasing vessel functionality and value.

## II. SPECIFICATION

For sizing of the system, it was used dimensions of available on the market long range luxury motor yacht. Chosen boat has following dimensions: length of deck 16.275m, beam:5.08m, full length: 16.505m, max. draft:1,225m and dry weight of 21250kg.

The boat moving in the water have to overcome resistances from the environment and cover energy needed for movement of the system devices losses and municipal energy needs. Resistive force in its simplified form in case of boat moving on stationary water can be calculated by formula  $R=0.5*k*CD*\rho*v^2*A$  where water density is assumed to be 1030 [kg/m<sup>3</sup>], and drag coefficient is approx.  $3.313*10^{-1}$  [2][3]. For better calculation of the force coefficient of additional resistances of 1,2 was assumed.[4] Effective power of the boat is obtained from multiplication of resistance and speed. Municipal needs of energy are estimated on the level of 5 kWh with four people on the boat. Considering that heating and cooker are not a part of electrical load of the system [5].

In the application of the solar power support on the boat is different than in case of land applications, because there is limitation of the available space. On the Fig.1. there is presented placement of solar panels on the boat. Solar panels will be placed on two areas of the boat and on attached trailer which will have possible extension when boat is stopped in the port.

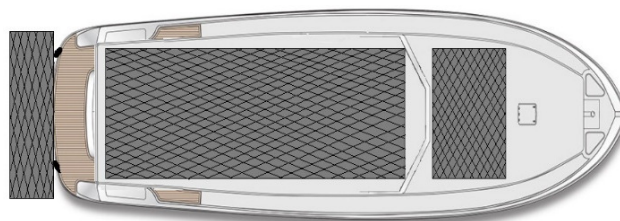

Figure 1. Concept of solar panels placement on the boat

Connected trailer made with stainless and strong material to provide good support for solar panels allows significant increment of available area for placement of solar panels, and possibility of expanding area of trailer while stop in port gives opportunity of faster charging on-board batteries due to higher power produced by solar panels Placing the trailer on the back of the boat without changing the front area of the boat, does not have big influence on the water resistances acting on the boat.

Different solar panels are chosen to make it appropriate for placement in different areas. On the roof and the bow Mono-Crystalline Photovoltaic Module with data present-ed in Table I. Transformer-less solution, Light Induced Degradation Free technology and high temperature coefficient. On the roof and bow total of 18 panels can be installed.

TABLE I - Panel datasheet of panel on roof, bow and trailer

| Panel datasheet of panel on roof and bow [6] |         |
|----------------------------------------------|---------|
| Nominal Power                                | 333 W   |
| Module Efficiency                            | 20,4 %  |
| Nominal Voltage                              | 54.7 V  |
| Nominal Current                              | 6.09 A  |
| Open Circuit Voltage                         | 64.9 V  |
| Short Circuit Current                        | 6.58 A  |
| Panel datasheet for panel on trailer [7]     |         |
| Nominal Power                                | 445 W   |
| Module Efficiency                            | 18 %    |
| Nominal Voltage                              | 182,8V  |
| Nominal Current                              | 2,43 A  |
| Open Circuit Voltage                         | 216,5 V |
| Short Circuit Current                        | 2,65 A  |

T... film CdTe semiconductor with data presented in Table I.

For power analysis while the boat is not moving energy produced by solar panels should be able to supply the system. Solar power installed on the boat is 7,78kW, and domestic needs are estimated on the level of 5kW on full load but usually all the load is not used at the same time, so after covering all the domestic needs there is still some extra power which can be stored. What proves that in case of and emergency solar panels will be able to support critical loads.

During movement of the boat it is considered that there are no municipal power needs, and all power produced by solar panels goes for covering energy needs for movement of the boat.

Fig.2. present characteristic of power needs of boat in reference of its speed and it is showed that energy needs until 17knots, and over that level of needed energy there is necessity to use diesel generator. For speed of 19 knots electric energy produced by solar power should cover around 75% of the load, while for speed of 29 knots it only covers 23% of the load. Even at the time when solar system covers only small part of the electricity needs of the system it ensures limitation of fuel consumption.

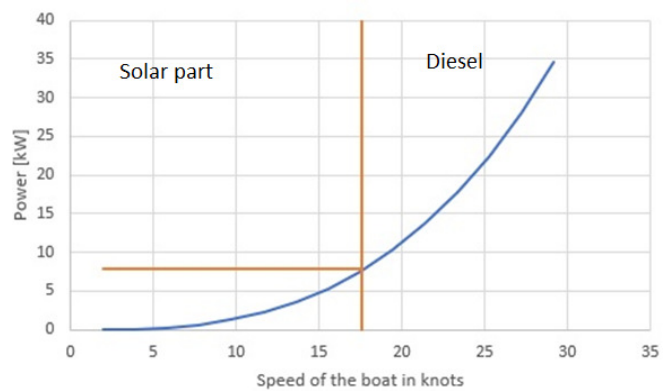

Figure 2. Power distribution

Design of the system allow possibility of covering full load with solar energy, covering all the load with the generators and driving on both supply system which allows to lower generators consumption, what allows high flexibility of the system and increases its reliability. DC system where chosen due to higher functionality of the system and predicted fuel savings. It also allows direct connection between battery and main switchboard.

As it is possible to see on the Fig.3. in the system there are two kinds of energy sources. Two diesel generators and battery charged by photovoltaics arrays. Main switchboard is divided for two parts, so in case of failure of one of the generators or busbars one part of the system still can be operating. Solar panels supply batteries thorough charge controllers, and battery supply power to the load. All system is designed as DC system and main switchboard is DC. Main loads of the system are screws driven by electric motors and distribution line. UPS system is installed for distribution line.

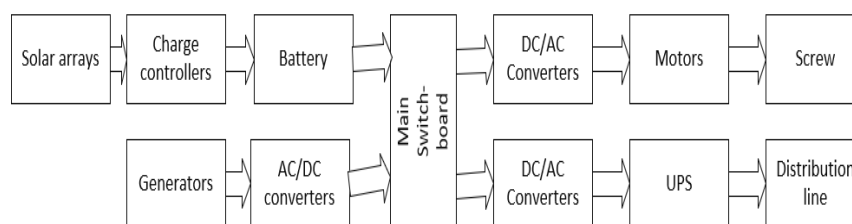

Figure 3. Block diagram of the system of electrical installation of the boat

### III. PROJECT

All the main elements for the design of the circuit were chosen from the solutions available on the market to create total concept of the system. Protection devices for the system are not sized but they are placed on the diagram as a preliminary concept is developed. AC to DC converters for generators selection and selection of DC to AC converters for motors and distribution line are not going to be presented in this paper.

#### A. Energy storage selection

As continuous supply of electricity is needed, energy produced by solar panels must be stored for use on no-sun periods, covering peaks of necessary energy and operation while generators are not working.

Important characteristics which batteries for solar systems should fulfil are high capacity, high cycle-based life span, low depth of discharge, allowable occasional deep dis-charge cycles without life span reduction, available very small charging currents, low self-discharge rate, good am-per-hour efficiency and no necessary maintenance.

$$\text{Capacity}_{\text{battery}} = (7780\text{Wh} * 1,1) / (0,8 * 0,8 * 48\text{V}) = 279\text{Ah}$$

For calculation of necessary capacity of the battery it is crucial to know nominal voltage of the battery. Also, capacity of the battery must be high enough to fulfill energy requirement.

Another important parameter is depth of dis-charge which is the ratio of discharged battery capacity to nominal battery capacity.

Deep cycle battery is preferred in applications with solar panels due to its toleration of cyclic charging and discharging without losses in performance. Life span of the battery is next factor to be considered. Number of cycles that a battery can carry out before its capacity reaches 80% of nominal capacity is a cycled based life span, and its mainly determined by battery type and DoD. To obtain capacity of the battery it is also necessary to know required energy.

TABLE II - Basic parameters of chosen battery [8]

|                                    |               |
|------------------------------------|---------------|
| Operating voltage                  | 44.8 to 58.1V |
| Max. charging, discharging current | 900 A         |
| Energy                             | 14.4kWh       |
| Capacity                           | 282Ah         |
| DoD                                | 80%           |

#### B. Charge controller selection

Solar charge controller is installed to manage the power going from the solar array to the battery bank. Solar charge controllers are being used in this system to protects installed battery from overcharging during the day and, from deep discharge during the night. One of the features of charge controllers is disconnection of the attached load when battery is low and turning it back when battery is charged back up.

An MPPT charge controller ensure that solar generator is operating at its maximum power point. This kind of charge controller increases power output about 15-30% in properly sized solar system with integrated battery.

In the project three solar charge controllers will be used due to use of two different types of solar panels, and because of placement of solar panels in different part of the boat.

Charge controller for array 1 which is array consisting form the panels placed on the roof of the boat and it is 16 panels in eight strings of 2 panels connected in series. Solar panels used in this array has included in table I.

$$V_{array} = V_{npanel} * n_s = 109.4V, V_{ocarray} = V_{oc} * n_s = 129.8V,$$

$$I_{array} = I_{npanel} * n_p = 48.7A, I_{scarray} = I_{scpanel} * n_p = 52.6A \text{ and}$$

$$P_{array} = V_{array} * I_{array} = 5330W$$

For this array charge controller have step down the voltage to necessary for the battery 48V.

TABLE III - Basic parameters of charge controller for panels arrays form the roof.[9]

|                               |            |
|-------------------------------|------------|
| Maximum operating voltage     | 187 VDC    |
| Maximum short circuit current | 100 ADC    |
| Nominal battery voltage       | 48 VDC     |
| Maximum output power          | 6600 watts |

Second charge controller is for array 2 created from series connection of solar panels on the bow. Solar panels used in this array are the same as in array1. Calculations for the second array was made in the same manner as for the first array For this array charge controller have step up the voltage to necessary for the battery 48V.

TABLE IV - Basic parameters of charge controller for panels array on the bow.[10]

|                                 |              |
|---------------------------------|--------------|
| Max. Solar Open Circuit Voltage | 150 volts DC |
| Maximum Battery Current         | 45 A         |
| Nominal battery voltage         | 48 V         |
| Max. output power               | 2400 W       |

Third charge controller is for array 3 created from parallel connection of two strings of two panels which create trailer. Another type of solar panels is used in this array has specification presented in the table II. Calculations for the second array was made in the same manner as for the first array. For this array charge controller have step down the voltage to necessary for the battery 48V.

TABLE V - Basic parameters of charge controller for panels which consist the trailer.[11]

|                                   |          |
|-----------------------------------|----------|
| Nominal battery voltage:          | 48 V     |
| Max PV array voltage (operating): | 195-550V |
| Array short-circuit current       | 35 A     |
| Max. output power                 | 4800 W   |
| Max. charge current               | 80 A     |
| Max. power conversion efficiency  | 96%      |

Electrical motor is chosen as a drive for the screw to ensure better maneuvering on low speed. Motor allows operation on different speeds what gives possibility of better operation. Chosen motor must have level of protection resistant to water jets and dust what mean IP code protection on the level of IP 55. Two of these motors are used in the design of the system, and each of them is connected to the different part of the main switchboard so in case of necessary maintenance or breakdown of one of the motors it is still possible to operate the other one.

**D. Generator selection**

Two generators are installed, one for each busbar of main switchboard so all necessary power can be delivered. This kind of solution increases reliability of the system because if one of the generators is out of order it is still possible to operate using one of the generators. Chosen generators are three-phase brushless 4 pole generators. Due to excellent fuel economy and minimum of required maintenance it is highly reliable power source. Diesel generators are safer than gasoline ones because gasoline has explosive nature and would have higher safety requirements.

It is better to have two generators of smaller nominal power than one big generator because generator should never run continuously with less than 25% of the load.

TABLE VII - Basic specification of generator set [13]

|                |          |
|----------------|----------|
| Rated Power    | 18kW     |
| Frequency      | 50Hz     |
| Speed          | 1500rpm  |
| Output Voltage | 230V     |
| Fuel Cons.     | 5.2 L/hr |

#### E. UPS system selection

To insure high reliability of the system UPS is used. UPS is a device that provides emergency power to a load in case of the main power supply failure. Using these systems allows supply of energy to the most needed loads while no supply from main energy source.

TABLE VIII - Basic data of the UPS system [14]

|                  |       |
|------------------|-------|
| Input voltage    | 230 V |
| Input frequency  | 50 Hz |
| Output power     | 720 W |
| Output voltage   | 230 V |
| Output frequency | 50 Hz |
| Time of charging | 8 h   |

#### F. Design of the solar part of the system

Solar part of the system is presented on Fig.4.

First array consists of parallel connection of 8 strings of 2 panels connected in series, each string of two panels is connected through disconnector so in case of necessary maintenance it is possible to disconnect one string without disconnecting all array. There is also possibility to disconnect whole array.

Second array consist of two panels connected in series and third array consist of parallel connection of two strings of two panels connected in series and are designed in the same manner as first one.

Each array is connected to the separated charge controller and all three controllers are connected in series. So, two charge controllers operate on it full power and third controller evens the output. All this system is connected to the battery which supply the electrical installation of the system.

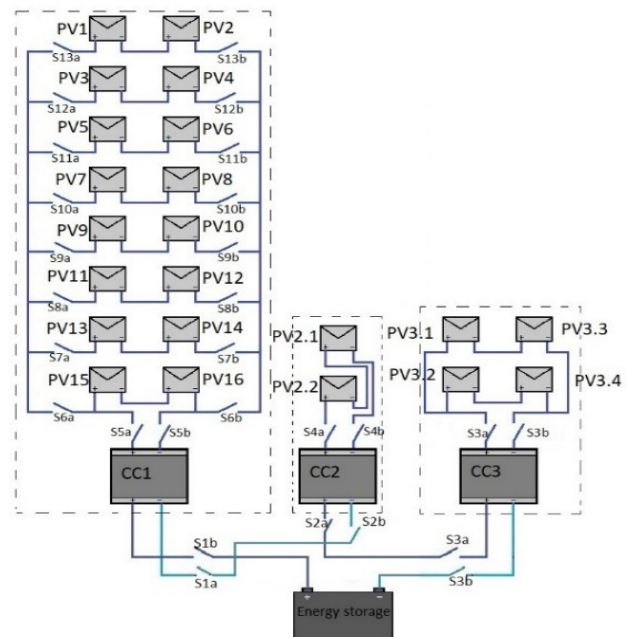

Figure 4. Diagram of solar part of the system

#### G. Design of the full system

Codes and basic data of the elements used in the system design are visible on the single line diagram of the circuit presented in Fig.5.

Designed system has DC main switch-board composed with two parts, which increases reliability of the system and in case of necessity allows operation of each part of the system separately. System is equipped with two energy sources, diesel generators and battery supplied by solar system. Solar system is presented on Fig.4.

There are two diesel generators connected via AC to DC converters to the main switchboard. Each generator set is connected to different part of the switchboard which increase system reliability. There are two types of loads connected into the switchboard.

The propulsion system driven by 3 phase electric motor, supplied by DC to AC converter. Second type of load is AC distribution line connected to main switchboard by the DC to AC converter. Distribution line is connected to the main switchboard by the DC to AC converter and UPS system.

IV. SIMULATION

Simulations was performed in PSIM software. Simulation circuit of solar part of the system uses basic scheme of step-down converter controlled with MPPT as charge controllers. In the simulation perturb and observe algorithm for maximum power point tracking method is used. MPPT is implemented to maximize the power generated by solar panels. The algorithms continuously adjust the impedance seen by solar panels to keep operation point of solar panels as close to maximum power point as possible under any condition.

Entire basic algorithm of perturb and observe method is presented in Fig.6. This Algorithm measures values of voltage and current to obtain power value. Depending on value of power voltage is increased and decreased to obtain appropriate output. Based on this the algorithm simulation circuit was prepared. To ensure maximum power algorithm perturbs the operating voltage. MPPT is simulated using Simplified C block.

Simulation system of solar part of the designed electrical installation presented on Fig.7. Solar panels outputs go to model of buck controller with MPPT and output of the controllers is connected to the battery. Buck converter is modeled with IGBT controlled with control system equipped with MPPT and other necessary devices. MPPT uses current and voltage sensors to control IGBT to obtain reference voltage.

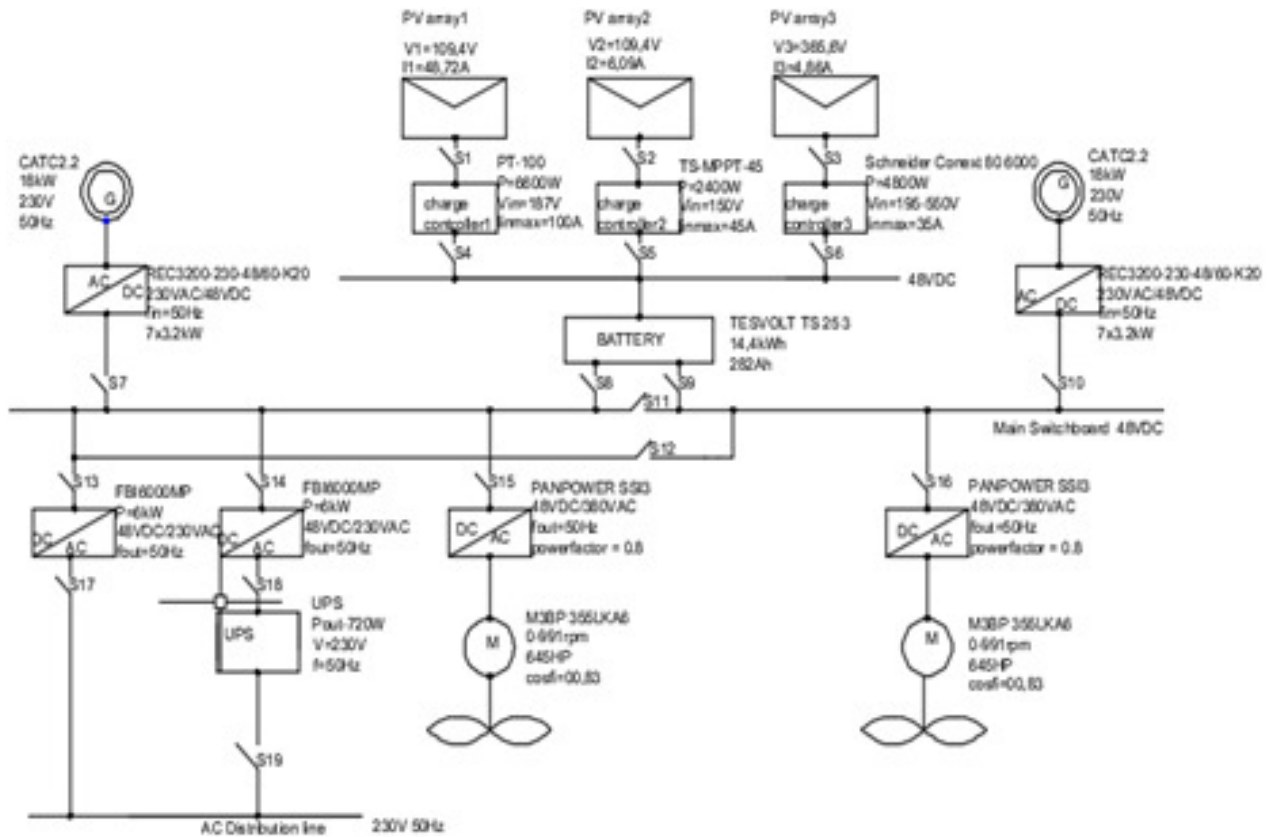

Figure 5. Diagram of the system

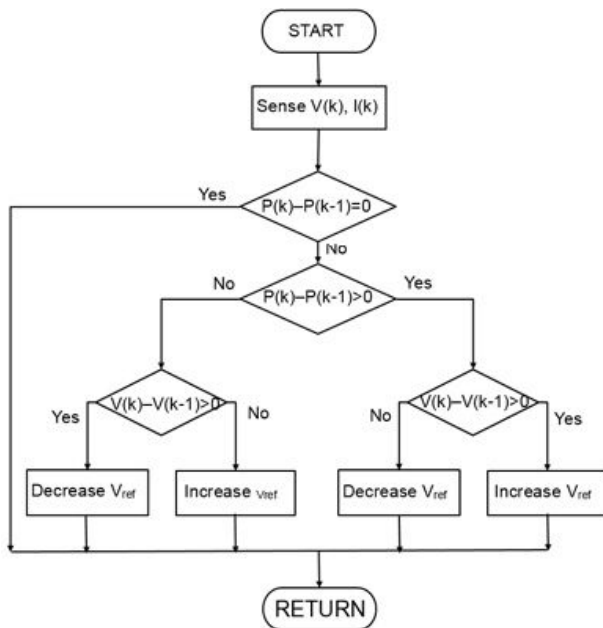

Figure 6. Algorithm of MPPT [15]

Results of the simulation of the solar part of the system are presented in figures 8, 9 and 10.

Characteristics presented on the Fig.8. shows that the voltage stays on the level close to 48V, what is value acceptable for the battery. Current form solar panels on the roof is equal 52.63A, current form panels on the bow is equal 6,09A and current from panels on the trailer is on the level of 5,3A

On the characteristic from Fig.9. it is visible that all the currents are stabilizing on the same level, and it is also possible to observe that current from the trailer stabilizes as last, it is due to the fact that it has the biggest difference between value of voltage from the panel and battery.

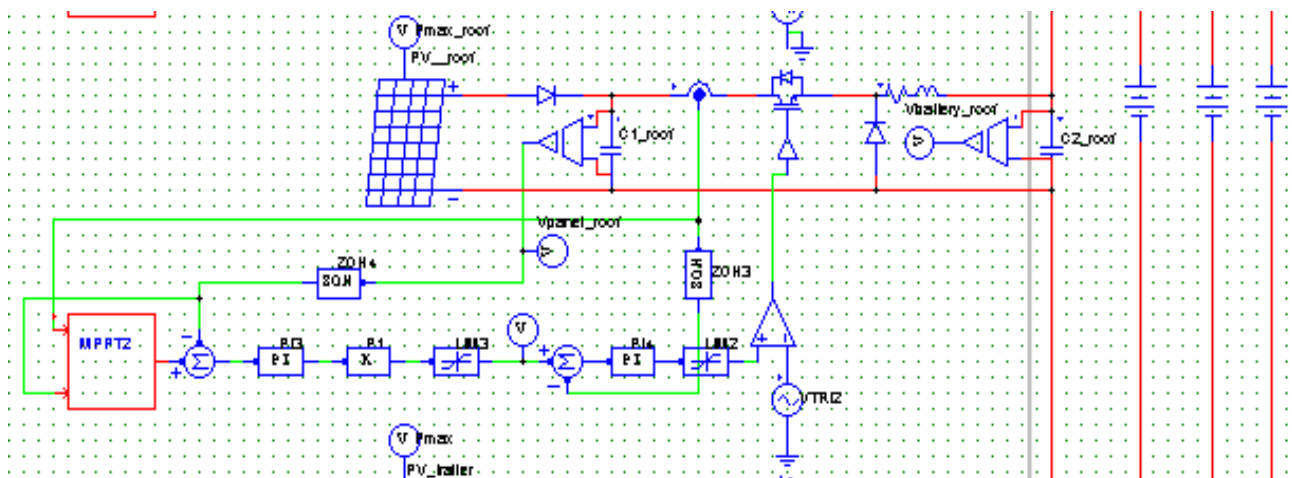

Figure 7. Part of the simulation model used in simulations

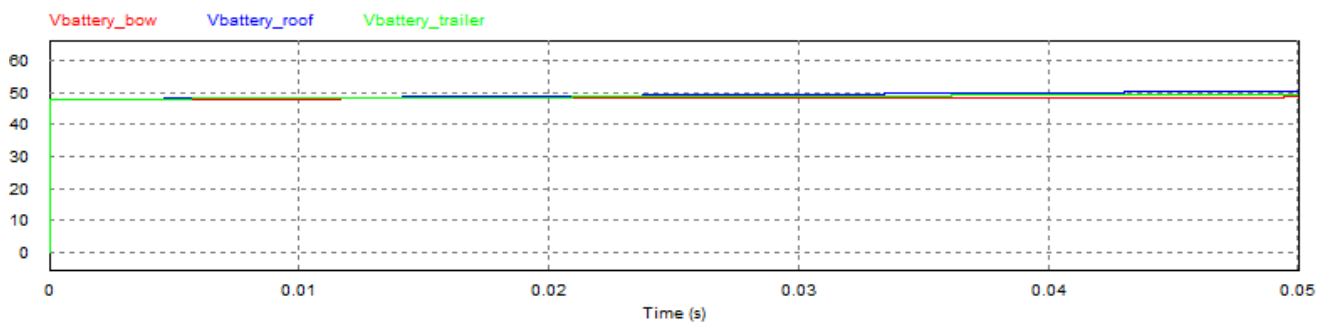

Figure 8. Simulation result- voltages after step down converter

Fig.10. present characteristics that show that all the lines are heading to maximum power point, achieving it and then oscillating around the maximum value. It is also visible that power value has the biggest oscillations for trailer panel what is due to the fact that it has the highest difference between value of the voltage form the solar panel.

**V. CONCLUSIONS**

This paper covered design and simulation of electrical installation for luxury boat supported with solar power. Design include the luxury boat of with hybrid system where solar panels are installed to support diesel generator.

Project consider solar panels placed on the roof bow of the boat and some additional panels mounted on the attached trailer. Designed electrical installation is an DC grid, what make layout of the vessel more functional due to more flexible placement of electrical components, improvement of dynamic response, maneuverability, and increases fuel savings.

There are two types of solar panels installed on the boat. Different solar panels are chosen to make it appropriate for placement in different areas.

Solar panels installed on the roof and bow are the monocrystalline photovoltaic. Array mounted on the roof is the biggest and produces 68% of power produced by solar system and panels form the bow produces 8,5%.

For improvement of the system performance project consider adding trailer to the boat to extend area of boat and get possibility of mounting additional solar panels on the boat. Trailer area is remaining 23% of total area of installed solar panels. Trailer does not create additional resistances because it fits into hydrodynamic tunnel created by the boat.

It can be considered to extend trailer area even more, but than it would require further studies of it influence on the water resistances influencing the boat. Solar part of the system consists of three arrays of solar panels, three charge controllers connected to the battery. Other generating part of the design consist of two diesel generators, to ensure enough power to drive the boat at higher speeds. There are two main load types in the system.

There is AC distribution line with UPS system and what is more the boat is equipped with two screws driven by electric motors

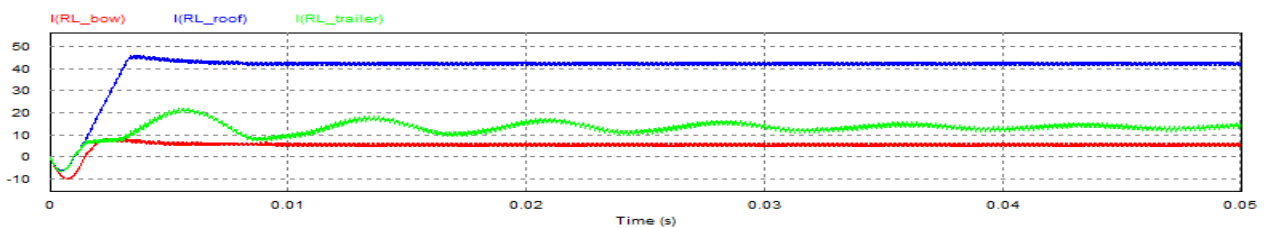

Figure 9. Simulation result- current comparison

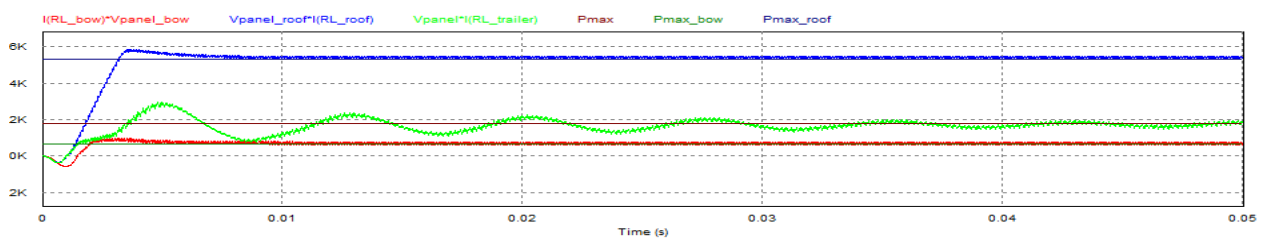

Figure 10. Simulation result-power comparison

For power analysis it is known that solar part of the system can cover all the critical loads in case of an emergency, it can also provide enough energy to cover municipal needs of energy, or it can cover all needs for energy to cover the movement of the boat up to speed of 17 knots, and over this level it is necessary to use the diesel generator.

With speed of 19 knots electric energy produced by solar power should cover around 75% of the load, while for speed of 29 knots it only covers 23% of the load. When solar system covers only small part of the electricity needs of the system it still ensures decrease in fuel consumption.

Simulation is performed only for solar part of the electrical installation. Circuit obtains voltage of 48V and it is also visible that ripples are very small. Also, maximum power point tracking device allows us to have the highest possible power output at the solar irradiation that we have.

To summarize, even at the time when power produced from the solar panels is not the highest it is beneficial to have solar panels in the circuit. Use of solar panels decreases fuel consumption and in case of breakdown of diesel generators it provides alternative source of energy which supply critical loads.

## VI. REFERENCES

1. Chowdhury, S.; Chowdhury, S.P.; Crossley, P. Microgrids and Active Distribution Networks. Herts, UK, Institution of Engineering and Technology, 2009,
2. Cheng-Wen Lin, Scott Percival, Eugene H. Gotimer. Viscous Drag Calculations for Ship Hull Geometry, Bethesda, Naval Surface Warfare Center, 1995
3. Mirosław Jurdziński, Technological and operational methods to reduce ship hull resistance due to reduce energy consumption on sea going ships, Scientific Journal of Gdynia Maritime University, 82/2013, Pages: 23-37
4. Tomasz Kniaziewicz, Leszek Piaseczny, Model symulacyjny nox podczas ruchu promu pasażersko-samochodowego, Postępy nauki i techniki nr15.
5. Tauron, Kalkulator zużycia energii elektrycznej w domu. <http://kalkulator.tauron.pl/h5/>. 4 /12/2017
6. Solartoday, SunForte PM096B00, [http://www.solartoday.nl/uploads/downloads/SF-PM096B00\\_ds\\_en%20\(1\).pdf](http://www.solartoday.nl/uploads/downloads/SF-PM096B00_ds_en%20(1).pdf). 10/11/2017
7. Firstsolar, FIRST SOLAR SERIES 6™ FS-6445 FS-6445A, <http://www.firstsolar.com/-/media/First-Solar/Technical-Documents/Series-6-Datasheets/Series-6-Datasheet.ashx>. 10/11/2017
8. Tesvolt, TESVOLT TS 25 3. <http://www.tesvolt.com/templates/tesvolt/files/pdf/EDB.TS.ENG-A.11b.pdf>. 16/11/2017
9. MagnumDimensions, PT-100 CHARGE CONTROLLER, <https://www.wholesalesolar.com/2950000/magnumenergy/chargecontrollers/magnum-energy-pt-100-charge-controller>. 29/11/2017
10. Morningstar, MPPT charge controller TS-MPPT-45, <https://2n1s7w3qw84d2ysnx3ia2bct-wpengine.netdna-ssl.com/wp-content/uploads/2014/02/TSMPTdsEng.pdf>. 29/11/2017
11. Schneider Electric, Conext MPPT 80 600 solar charge controller. <https://41j5tc3akbrn3uezx5av0jj1bgm-wpengine.netdna-ssl.com/wp-content/uploads/2017/10/DS20171023-Conext-MPPT-80-600-Datasheet.pdf>, 29/11/2017
13. CATERPILLAR, C2.2 Marine Generator Set, [https://www.cat.com/en\\_US/products/new/power-systems/marine-power-systems/marine-generator-sets/18494391.html](https://www.cat.com/en_US/products/new/power-systems/marine-power-systems/marine-generator-sets/18494391.html). 28/11/2017
14. Schneider Electric, APC Power-Saving Back-UPS Pro 1200 BR1200G-FR, [https://www.schneider-electric.com/en/product/BR1200G-FR\\_APC/apc-power-saving-back-ups-pro-1200%2C-230v%2C-cee-7-5](https://www.schneider-electric.com/en/product/BR1200G-FR_APC/apc-power-saving-back-ups-pro-1200%2C-230v%2C-cee-7-5). 28/11/2017
15. Mathworks, MPPT algorithm. <https://www.mathworks.com/discovery/mppt-algorithm.html>. 4/01/2018

## COLABORARAM NESTA EDIÇÃO:



**Aleksandra Wawrzyniak**

**1150113@isep.ipp.pt**

Erasmus student at ISEP from Warsaw University of Technology from master's degree in electrical engineering - Networks and Electricity Systems. Engineering Degree in Electrical Engineering. Worked on projects in concerning power electronics and design of electrical installations.



**Alexandre Chamusca**

**achamusca@xkt.pt**

Engenheiro Eletrotécnico. Consultor Soluções Integradas Segurança. XKT - Soluções Integradas de Segurança.

**André P. Mendes**

**pereiramendes.andre@gmail.com**

Instituto de Telecomunicações, Department of Electrical and Computer Engineering, 3030-290 Coimbra, Portugal

**André M. S. Mendes**

**amsmendes@ieee.org**

Department of Electrical and Computer Engineering, University of Coimbra/Instituto de Telecomunicações, 3030-290 Coimbra, Portugal



**António Augusto Araújo Gomes**

**aag@isep.ipp.pt**

Professor adjunto do Departamento de Engenharia Eletrotécnica do Instituto Superior de Engenharia do Porto desde 1999.

**Bruno Baptista**

**brunoricardo@weg.net**

WEGeuro - Indústria Eléctrica, S.A., 4470-605 Maia, Portugal



**Célia Maria dos Santos Carneiro**

**celia\_carneiro@live.com.pt**

Licenciada em Engenharia Electrotécnica – Ramo Sistemas de Energia, pelo Instituto Superior de Engenharia do Porto (ISEP). Mestre em Engenharia Eletrotécnica – Sistemas Eléctricos de Energia. Em 2016 entrou para o programa de Trainees da empresa REN, onde atualmente, desempenha funções de operadora da rede eléctrica de MAT no COR- Vermoim.

## COLABORARAM NESTA EDIÇÃO:



**César M.S. Sanos**

**cesar.s.santos03@gmail.com**

Licenciatura em Engenharia de Sistemas de Engenharia Renovável, no Instituto Politécnico de Viana do Castelo. Aluno do curso de mestrado em Energias Sustentáveis, no Instituto Superior de Engenharia do Porto.

**João Dias**

**joao.dias@ua.pt**

CESAM – Centro de Estudos do Ambiente e do Mar, UA – Universidade de Aveiro, Aveiro.



**João Pedro Pereira da Rocha**

**1181274@isep.ipp.pt**

Aluno do curso de mestrado em Energias Sustentáveis, no Instituto Superior de Engenharia do Porto.

**Marina S. Perdigão**

**perdigao@isec.pt**

Instituto Superior de Engenharia de Coimbra, Instituto Politécnico de Coimbra/Instituto de Telecomunicações, 3030-199 Coimbra, Portugal



**Pedro Miguel Azevedo de Sousa Melo**

**pma@isep.ipp.pt**

Mestre em Automação, Instrumentação e Controlo pela Faculdade de Engenharia da Universidade do Porto. Aluno do Programa Doutoral em Engenharia Eletrotécnica e de Computadores, na Faculdade de Engenharia da Universidade do Porto. Docente do Instituto Superior de Engenharia do Porto desde 2001. Desenvolveu atividade de projetista de instalações elétricas de BT na DHV-TECNOPOPOR.

