

NONLINEAR DYNAMICS, CHAOS, CONTROL, AND THEIR APPLICATIONS TO ENGINEERING SCIENCES.

Volume 4: Recent Developments in Nonlinear Phenomena.

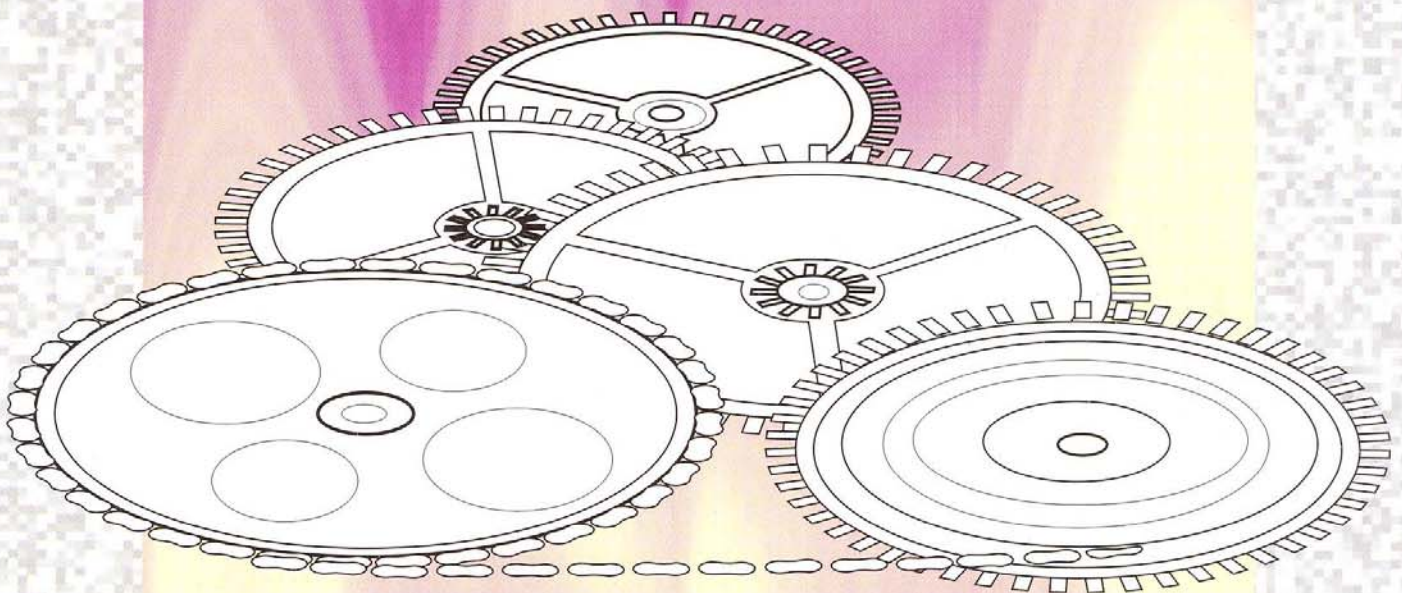

José Manoel Balthazar
Paulo Batista Gonçalves
Reyolando M.F.L.R.F. Brasil
Iberê L. Caldas
Felipe B. Rizatto
Editors.

Published by

Brazilian Society of Mechanical Sciences (ABCM)

American Academy of Mechanics (AAM)

Brazilian Society of Applied and Computacional Mathematics (SBMAC)

Società Italiana di Matematica Applicata e Industriale (SIMAI)

2002.

SYSTEM MODELING AND CONTROL THROUGH FRACTIONAL-ORDER ALGORITHMS

J. A. Tenreiro Machado
Instituto Superior de Engenharia do Porto
Departamento de Engenharia Electrotécnica, 4200 Porto, Portugal

ABSTRACT

The theory of fractional calculus goes back to the beginning of the theory of differential calculus but its inherent complexity postponed the application of the associated concepts. In the last decade the progress in the areas of chaos and fractals revealed subtle relationships with the fractional calculus leading to an increasing interest in the development of the new paradigm. In the area of automatic control preliminary work has already been carried out but the proposed algorithms are restricted to the frequency domain. The paper discusses the design of fractional-order discrete-time controllers. The algorithms studied adopt the time domain, which makes them suited for z -transform analysis and discrete-time implementation. The performance of discrete-time fractional-order controllers with linear and nonlinear systems is also investigated.

1. INTRODUCTION

Fractional calculus is a natural extension of the classical mathematics. In fact, since the beginning of the theory of differential and integral calculus, mathematicians such as Euler and Liouville investigated their ideas on the calculation of non-integer order derivatives and integrals. Nevertheless, in spite of the work that has been done in the area, the application of fractional derivatives and integrals (*FDIs*) has been scarce until recently. In the last years, the advances in the theory of chaos revealed relations with *FDIs*, motivating a renewed interest in this field.

The basic aspects of the fractional calculus theory and the study of its properties can be addressed in references [1-5] while research results can be found in [6-13]. In what concerns the application of *FDI* concepts we can mention a large volume of research about viscoelasticity/damping [14-32] and chaos/fractals [33-36]. However, other scientific areas are currently paying attention to the new concepts and we can refer the adoption of *FDIs* in biology [37], electronics [38], signal processing [39-41], system identification [42], diffusion and wave propagation [43-46], percolation [47], modeling and identification [48-49], chemistry [50], irreversibility [51] and others.

Inspired by the fractional calculus several researchers on automatic control proposed algorithms based on the frequency [52-53] and the discrete-time [54-55] domains. This work is still giving its first steps and, consequently, many aspects remain to be investigated. This paper analyses several approaches to implement *FDIs* in discrete-time control systems and, in this line of thought, the paper is organized as follows. Section two starts by introducing the main mathematical aspects concerning the fractional calculus. Sections three and four analyze the frequency-domain and the discrete-time approximations to *FDIs*, respectively. Based on the proposed discrete-time *FDI* approximation, sections five and six investigate the performance of fractional order algorithms with linear and nonlinear control systems, respectively, from a stability and robustness point of view. Finally, section seven draws the main conclusions.

2. MATHEMATICAL FORMULATION OF FRACTIONAL DERIVATIVES

Since the foundation of the differential calculus the generalization of the concept of derivative and integral to a non-integer order α has been the subject of several approaches. Due to this reason there are various definitions of *FDIs* (Table I) which are proved to be equivalent.

Table I Definitions of *FDIs*

Liouville	$\left(I_c^\alpha \varphi\right)(x) = \frac{1}{\Gamma(\alpha)} \int_{-\infty}^x \frac{\varphi(t)}{(x-t)^{1-\alpha}} dt; \left(D_c^\alpha f\right)(x) = \frac{1}{\Gamma(1-\alpha)} \frac{d}{dx} \int_{-\infty}^x \frac{f(t)}{(x-t)^\alpha} dt, -\infty < x < +\infty$
Riemann-Liouville	$\left(I_{a+}^\alpha \varphi\right)(x) = \frac{1}{\Gamma(\alpha)} \int_a^x \frac{\varphi(t)}{(x-t)^{1-\alpha}} dt, a < x; \left(D_{a+}^\alpha f\right)(x) = \frac{1}{\Gamma(1-\alpha)} \frac{d}{dx} \int_a^x \frac{f(t)}{(x-t)^\alpha} dt, a < x$
Hadamard	$\left(I_+^\alpha \varphi\right)(x) = \frac{1}{\Gamma(\alpha)} \int_0^x \frac{\varphi(t)}{t[\ln(x/t)]^{1-\alpha}} dt, x > 0, a > 0; \left(D_{a+}^\alpha f\right)(x) = \frac{\alpha}{\Gamma(1-\alpha)} \int_0^x \frac{f(x)-f(t)}{t[\ln(x/t)]^{1+\alpha}} dt$
Grünwald-Letnikov	$\left(I_{a+}^\alpha \varphi\right)(x) = \frac{1}{\Gamma(\alpha)} \lim_{h \rightarrow +0} \left[h^\alpha \sum_{j=0}^{\left[\frac{x-a}{h}\right]} \frac{\Gamma(\alpha+j)}{\Gamma(j+1)} \varphi(x-jh) \right]$
Chen	$\left(I_c^\alpha \varphi\right)(x) = \frac{1}{\Gamma(\alpha)} \int_c^x \varphi(t)(x-t)^{\alpha-1} dt; \left(D_c^\alpha f\right)(x) = \frac{1}{\Gamma(1-\alpha)} \frac{d}{dx} \int_c^x f(t)(x-t)^{-\alpha} dt, x > c$
Marchaud	$\left(D_+^\alpha f\right)(x) = \frac{\alpha}{\Gamma(1-\alpha)} \int_{-\infty}^x \frac{f(x)-f(t)}{(x-t)^{1+\alpha}} dt$
Fourier	$F\left\{I_{\pm}^\alpha \varphi\right\} = F\{\varphi\} / (\pm j\omega)^\alpha, 0 < \text{Re}(\alpha) < 1; F\left\{D_{\pm}^\alpha \varphi\right\} = (\pm j\omega)^\alpha F\{\varphi\}, \text{Re}(\alpha) \geq 0$
Laplace	$L\left\{I_{0+}^\alpha \varphi\right\} = L\{\varphi\} / s^\alpha, \text{Re}(\alpha) > 0; L\left\{D_{0+}^\alpha \varphi\right\} = s^\alpha L\{\varphi\}, \text{Re}(\alpha) \geq 0$

Based on the proposed definitions it is possible to calculate the *FDIs* of several functions leading to the expressions presented in Table II. Nevertheless, from the control point of view some definitions seem

more attractive, namely when thinking in a real-time calculation. The problem of devising and implementing fractional-order algorithms will be the matter of the next sections.

Table II *FDIs* of several functions

$\varphi(x), x \in \mathfrak{R}$	$(I_+^\alpha \varphi)(x), x \in \mathfrak{R}, \alpha \in \mathbb{C}$
$(x-a)^{\beta-1}$	$\frac{\Gamma(\beta)}{\Gamma(\alpha+\beta)} (x-a)^{\alpha+\beta-1}, \text{Re}(\beta) > 0$
$e^{\lambda x}$	$\lambda^{-\alpha} e^{\lambda x}, \text{Re}(\lambda) > 0$
$\begin{cases} \sin(\lambda x) \\ \cos(\lambda x) \end{cases}$	$\lambda^{-\alpha} \begin{cases} \sin(\lambda x - \alpha \pi/2) \\ \cos(\lambda x - \alpha \pi/2) \end{cases}, \lambda > 0, \text{Re}(\alpha) > 1$
$e^{\lambda x} \begin{cases} \sin(\gamma x) \\ \cos(\gamma x) \end{cases}$	$\frac{e^{\lambda x}}{(\lambda^2 + \gamma^2)^{\alpha/2}} \begin{cases} \sin(\gamma x - \alpha \phi) \\ \cos(\gamma x - \alpha \phi) \end{cases}, \phi = \arctan(\gamma/\lambda), \gamma > 0, \text{Re}(\lambda) > 1$

3. FREQUENCY-DOMAIN APPROXIMATION TO FRACTIONAL-ORDER DERIVATIVES

In order to analyze the frequency-based approach to $D^\alpha, 0 < \alpha < 1$, let us consider the recursive circuit represented on Figure 1 such that:

$$I = \sum_{i=1}^n I_i, R_{i+1} = \frac{R_i}{\varepsilon}, C_{i+1} = \frac{C_i}{\eta} \quad (1)$$

where η and ε are scale factors, I is the current due to an applied voltage V and R_i and C_i are the resistance and capacitance elements of the i^{th} branch of the circuit.

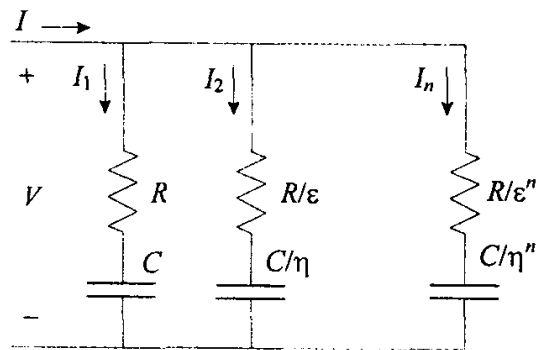

Fig. 1 Electrical circuit with a recursive association of resistance and capacitance elements.

The admittance $Y(j\omega)$ is given by:

$$Y(j\omega) = \frac{I(j\omega)}{V(j\omega)} = \sum_{i=0}^n \frac{j\omega C \epsilon^i}{j\omega CR + (\eta\epsilon)^i} \quad (2)$$

Figure 2 shows the asymptotic Bode diagrams of amplitude and phase of $Y(j\omega)$. The pole and zero frequencies (ω_i and ω'_i) obey the recursive relationships:

$$\frac{\omega'_{i+1}}{\omega'_i} = \frac{\omega_{i+1}}{\omega_i} = \epsilon\eta, \quad \frac{\omega_i}{\omega'_i} = \epsilon, \quad \frac{\omega'_{i+1}}{\omega_i} = \eta \quad (3)$$

From the Bode diagram of amplitude or of phase, the average slope m' can be calculated as:

$$m' = \frac{\log \epsilon}{\log \epsilon + \log \eta} \quad (4)$$

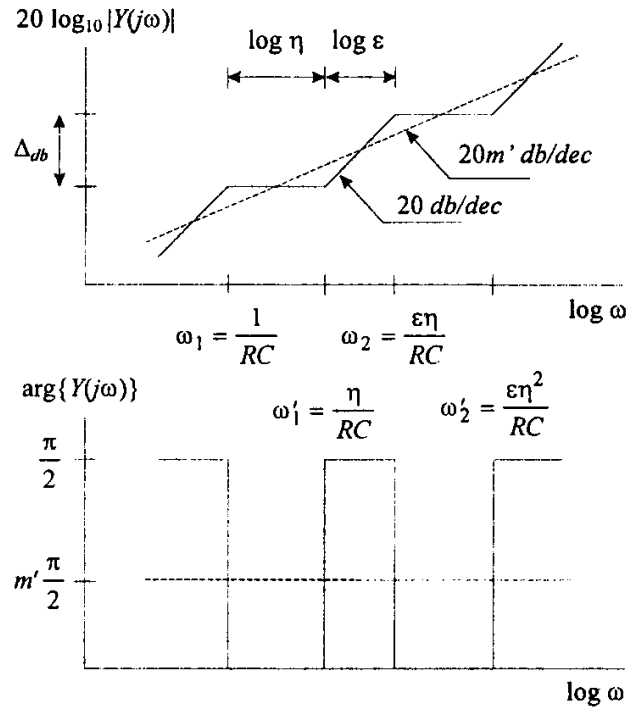

Fig. 2 Bode diagrams of amplitude and phase of $Y(j\omega)$.

The fractional order of the frequency response is due to the recursive nature of the circuit. In fact, the admittance $Y(j\omega)$ follows the recursive formula:

$$Y\left(\frac{\omega}{\eta\epsilon}\right) = \frac{1}{\epsilon} Y(\omega) \quad (5)$$

with solution in accordance with (4) (where ψ is a scale factor):

$$Y(\omega) = \psi(j\omega)^{-m'}, \quad m' = \frac{\log \varepsilon}{\log \varepsilon + \log \eta} \quad (6)$$

Consequently, the circuit of Fig. 1 represents an approach to D^α , $0 < \alpha < 1$, with $m' = \alpha$, based on a recursive pole/zero placement in the frequency domain.

A second aspect of *FDI* algorithms can be illustrated through the elemental control system represented in Figure 3, with open-loop transfer function $G(s) = Ks^{-\alpha}$ ($1 < \alpha < 2$) in the forward path. The open-loop Bode diagrams (Figure 4) of amplitude and phase have a slope of $-20\alpha \text{ dB/dec}$ and a constant phase of $-\alpha\pi/2 \text{ rad}$, respectively. Therefore, the closed-loop system has a constant phase margin of $\pi(1 - \alpha/2) \text{ rad}$, that is independent of the system gain K . Likewise, this important property is also revealed through the root-locus depicted in Figure 5. In fact, when $1 < \alpha < 2$ the root-locus follows the relation $\pi - \pi/\alpha = \cos^{-1} \zeta$, where ζ is the damping ratio, independently of the system gain K .

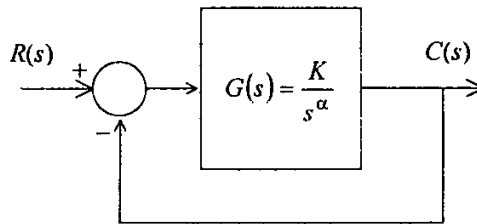

Fig. 3 Block diagram for an elemental feedback control system of fractional order α .

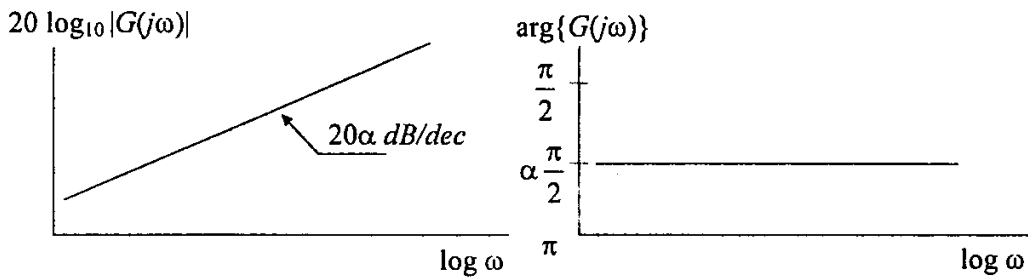

Fig. 4 Open-loop Bode diagrams of amplitude and phase for a system of fractional order $1 < \alpha < 2$.

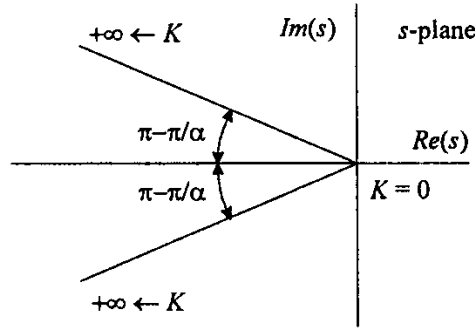

Fig. 5 Root locus for a feedback control system of fractional order $1 < \alpha < 2$.

In conclusion, the Laplace/Fourier definition (Table I) for a derivative of order $\alpha \in \mathbb{C}$ is a 'direct' generalization of the classical integer-order scheme with the multiplication of the signal transform by the $s/j\omega$ operator. In what concerns automatic control theory this means that frequency-based analysis methods have a straightforward adaptation to *FDIs*. Nevertheless, this approach has several drawbacks because the implementation of *FDIs* based on the Laplace/Fourier definition adopts the frequency domain and requires an infinite number of poles and zeros obeying a recursive relationship [52]. In a real approximation the finite number of poles and zeros yields a ripple in the frequency response and a limited bandwidth. Moreover, the digital conversion of the scheme requires further steps and additional approximations making difficult to analyze the final algorithm. The method is restricted to cases where a frequency response is well known and, in other circumstances, problems occur for its implementation.

4. FRACTIONAL-ORDER DISCRETE-TIME CONTROL ALGORITHMS

Based on the concept of fractional differential of order α , the Letnikov definition (Table I) of a derivative of fractional order α of the signal $x(t)$, $D^\alpha x(t)$, leads to the expression:

$$D^\alpha x(t) = \lim_{h \rightarrow 0} \left[\frac{1}{h^\alpha} \sum_{k=0}^{\infty} (-1)^k \frac{\Gamma(\alpha+1)}{\Gamma(k+1)\Gamma(\alpha-k+1)} x(t-kh) \right] \quad (7)$$

where Γ is the gamma function and h is the time increment. This formulation [54] inspired a discrete-time *FDI* calculation algorithm, based on the approximation of the time increment h through the sampling period T , yielding the equation in the z domain:

$$D^\alpha(z^{-1}) \approx \frac{1}{T^\alpha} \sum_{k=0}^{\infty} \frac{(-1)^k \Gamma(\alpha+1)}{k! \Gamma(\alpha-k+1)} z^{-k} = \left(\frac{1-z^{-1}}{T} \right)^\alpha \quad (8)$$

A real implementation of (8) corresponds to a n -term truncated series given by:

$$D^\alpha(z^{-1}) \approx \frac{1}{T^\alpha} \sum_{k=0}^n \frac{(-1)^k \Gamma(\alpha+1)}{k! \Gamma(\alpha-k+1)} z^{-k} = Trunc_n \left\{ \left(\frac{1-z^{-1}}{T} \right)^\alpha \right\} \quad (9)$$

Nevertheless, the properties of this and other approaches must be further studied and, bearing these facts in mind, in the sequel we analyze several discrete-time approximations to *FDIs*. We start by considering the well-known $s \rightarrow z$ conversion schemes (also called analog to digital open-loop design methods) of Euler (or first backward difference), Tustin (or bilinear) and Simpson. Note that the Letnikov approach (8) is similar to the Euler scheme. In our study we shall adopt for D^α expressions that are the generalization to non-integer exponents of these conversion methods as represented in Table III. The fractional-order conversion schemes lead to non-rational z -formulae. Therefore, in order to get rational expressions we expand them into Taylor series and the final algorithm corresponds to a n -term truncated series.

Table III Discrete-time conversion schemes

Method	$s \rightarrow z$ conversion	Taylor series
Euler, Letnikov, First backward difference	$s^\alpha \approx \left[\frac{1}{T} (1-z^{-1}) \right]^\alpha$	$\left(\frac{1}{T} \right)^\alpha \left[1 - \alpha z^{-1} + \frac{\alpha(\alpha-1)}{2!} z^{-2} \dots \right]$
Tustin	$s^\alpha \approx \left(\frac{2}{T} \frac{1-z^{-1}}{1+z^{-1}} \right)^\alpha$	$\left(\frac{2}{T} \right)^\alpha \left[1 - 2\alpha z^{-1} + 2\alpha^2 z^{-2} \dots \right]$
Simpson	$s^\alpha \approx \left[\frac{3}{T} \frac{(1+z^{-1})(1-z^{-1})}{1+4z^{-1}+z^{-2}} \right]^\alpha$	$\left(\frac{3}{T} \right)^\alpha \left[1 - 4\alpha z^{-1} + 2\alpha(4\alpha+3)z^{-2} \dots \right]$

These three approximations and the corresponding Taylor truncated series have distinct properties that must be analyzed before getting into a control system implementation. For example, the log-log chart of Figure 6 shows the amplitude absolute values of the Taylor series coefficients *versus* the term order when approximating the $\alpha = 1/2$ derivative:

$$\text{Letnikov: } D^{1/2}(z^{-1}) \approx \sqrt{\frac{1}{T}} \left(1 - \frac{1}{2} z^{-1} - \frac{1}{8} z^{-2} - \frac{1}{16} z^{-3} - \frac{5}{128} z^{-4} - \frac{7}{256} z^{-5} \dots \right) \quad (10a)$$

$$\text{Tustin: } D^{1/2}(z^{-1}) \approx \sqrt{\frac{2}{T}} \left[(1-z^{-1}) + \frac{1}{2} (z^{-2} - z^{-3}) + \frac{3}{8} (z^{-4} - z^{-5}) \dots \right] \quad (10b)$$

$$\text{Simpson: } D^{1/2}(z^{-1}) \approx \sqrt{\frac{3}{T}} \left(1 - 2z^{-1} + 5z^{-2} - 16z^{-3} + \frac{105}{2} z^{-4} - 177z^{-5} \dots \right) \quad (10c)$$

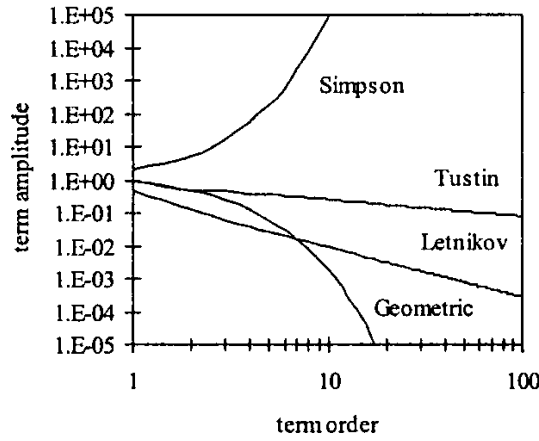

Fig. 6 Amplitude of the Taylor series coefficients *versus* the term order when approximating the $D^{1/2}$ with the Letnikov, Tustin and Simpson algorithms.

For simplicity, in the chart the gains of the approximations are not represented.

Analyzing the results we conclude that:

- While an integer-order derivative implies simply a finite series, the fractional-order derivative requires an infinite number of terms. This means that integer derivatives are ‘local’ operators in opposition with fractional derivatives that have, implicitly, a ‘memory’ of all past events.
- The ‘memory’ property of the fractional derivatives is highlighted when we study the magnitude of the series coefficients. For comparison purposes in Figure 6 it is also plotted the coefficients of a geometric series having the three initial terms similar to those of the Tustin series, that is:

$$\text{Geometric: } 1 - z^{-1} + \frac{1}{2}z^{-2} - \frac{1}{4}z^{-3} + \frac{1}{8}z^{-4} - \frac{1}{16}z^{-5} - \dots = \frac{2 - z^{-1}}{2 + z^{-1}} \quad (11)$$

The term coefficients of the geometric series decay rapidly while those of the Tustin approximation for the fractional-order derivative have a constant diminishing. Therefore, *FDIs* have a kind of logarithmic-time memory that gives a higher importance to past events.

- The Tustin and Simpson approximations $D^{1/2}$ seem problematic. In the first case, the coefficients decay with the term order but they appear in pairs of similar magnitude. Therefore, a series truncation of even or odd order will reveal distinct characteristics and, consequently, poor convergence properties. The Simpson approach requires a series with increasing coefficients showing, clearly, convergence problems.

The alternative of the *FDI* ‘direct’ implementation in the z -domain (the so-called discrete-time system design method) leads to poor results. For an open-loop system with transfer function $G(s)$, a first-order sample/hold and a D^α ($0 < \alpha < 1$) controller, we get:

$$D^\alpha(z^{-1}) = \frac{Z[s^\alpha G(s)]}{Z\left[\frac{1-e^{-sT}}{s} G(s)\right]} \quad (12)$$

For example, with $G(s) = 1/s^2$ it yields:

$$D^\alpha(z^{-1}) = \frac{Z\left(\frac{1}{s^{2-\alpha}}\right)}{Z\left(\frac{1-e^{-sT}}{s} \frac{1}{s^2}\right)} = \frac{2}{T^{1+\alpha}\Gamma(2-\alpha)} \frac{(1-z^{-1})^2}{1+z^{-1}} (1 + 2^{1-\alpha}z^{-1} + 3^{1-\alpha}z^{-2} + \dots) \quad (13)$$

Adopting $\alpha = 1/2$ in (13), for comparison purposes, the Taylor series expansion results:

$$D^{1/2}(z^{-1}) \approx \frac{4}{T^{3/2}\sqrt{\pi}} \left[1 - (3-\sqrt{2})z^{-1} + (4+\sqrt{3}-3\sqrt{2})z^{-2} - (3\sqrt{3}+2-4\sqrt{2})z^{-2} + \dots \right] \quad (14)$$

The series coefficients diminish very slowly showing convergence problems that were confirmed in the z -domain root-locus. Moreover, for a different transfer function $G(s)$ we need to recalculate the expressions in (13) and (14). Therefore, this method will not be considered in the next section, where the properties of Table III formulae will be further analyzed from a control system perspective.

5. PERFORMANCE OF *FDI* APPROXIMATIONS IN LINEAR CONTROL SYSTEMS

A mass M with a time delay T_D may be considered as a simple prototype system. Therefore, in order to study the performance of the *FDI* approximations in control algorithms we adopt a system with transfer function:

$$G(s) = \frac{e^{-sT_D}}{Ms^2} \quad (15)$$

An important property to be tested in the *FDI* approximations for control consists in the stability of the resulting closed-loop system.

Figure 7 shows the root-locus, in the z domain, for the three *FDI* schemes when implementing a $D^{1/2}$ controller, without any series truncation, for the case of $M=1$ and $T_D=0$ in (15). For an infinite series the Letnikov algorithm seems inferior while the Simpson method looks preferable. However, for a 5th order series truncation we get the results of Figure 8. As pointed out in the previous section, the Letnikov algorithm is 'robust' in what concerns the series truncation while the root-locus reveals increasing stability problems when passing to the Tustin and Simpson schemes. In fact, this conclusion can be confirmed tacking other values of α in the control algorithm and analyzing both the root-locus and the time responses.

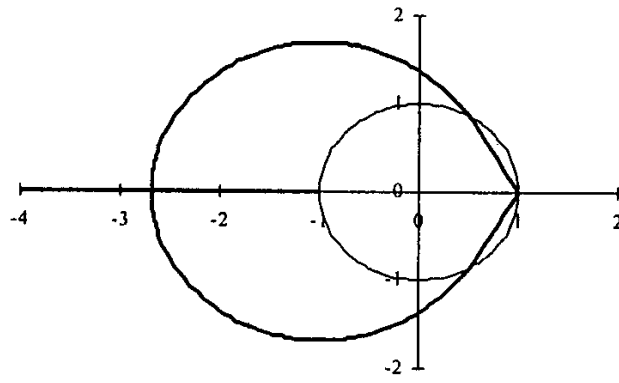

a)

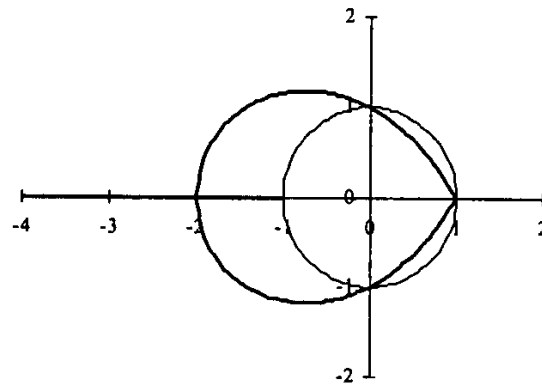

b)

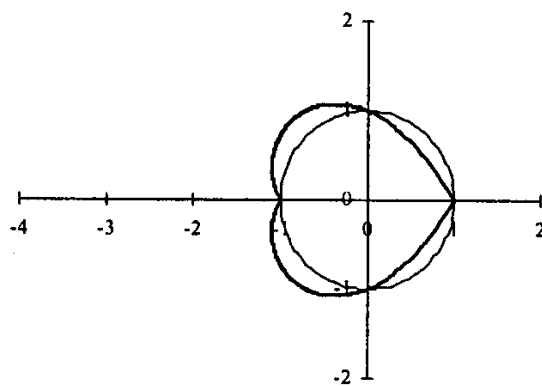

c)

Fig. 7 Root-locus for $G(s) = e^{-sT_D} / Ms^2$ with $M = 1$ and $T_D = 0$ under the control of a infinite series $D^{1/2}$ algorithm based on the approach of a) Letnikov b) Tustin c) Simpson.

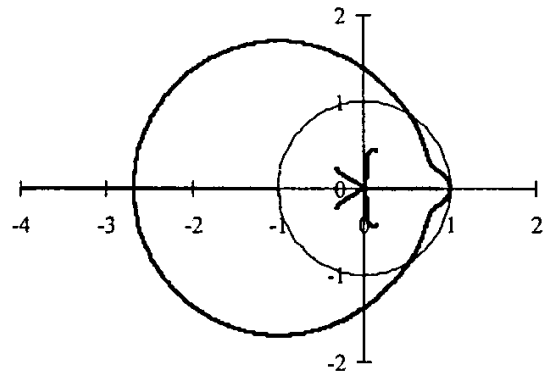

a)

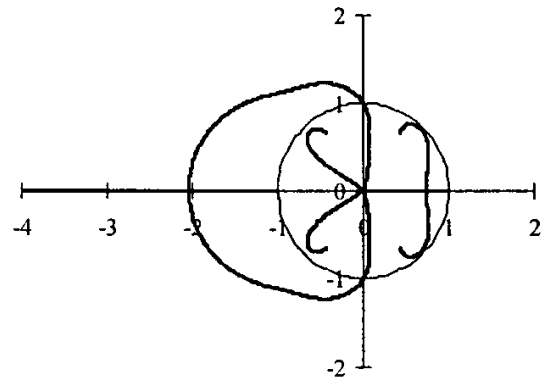

b)

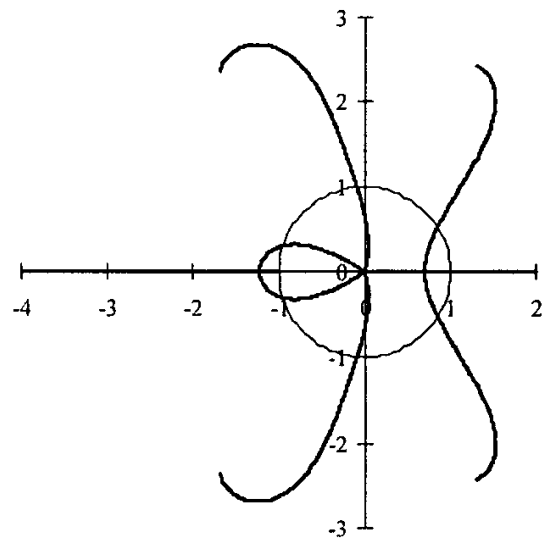

c)

Fig. 8 Root-locus for $G(s) = e^{-sT_D} / Ms^2$ with $M = 1$ and $T_D = 0$ under the control of a 5th order series approximation of $D^{1/2}$ algorithm based on the approach of a) Letnikov b) Tustin c) Simpson.

A second aspect to be tested from the control viewpoint is the controller performance when confronted with system parameter deviations. Therefore, in Figure 9 we compare the system time response with a Letnikov-based $D^{1/2}$ control algorithm for time delays of $T_D = 0 \text{ sec}$ and $T_D = 0.1 \text{ sec}$. The sampling period is $T = 0.1 \text{ sec}$ and the controller gain is $K = 10\sqrt{2/T}$. Moreover, in order to analyze the response for distinct series truncation orders, namely for $n = 3, 4$ and 5 .

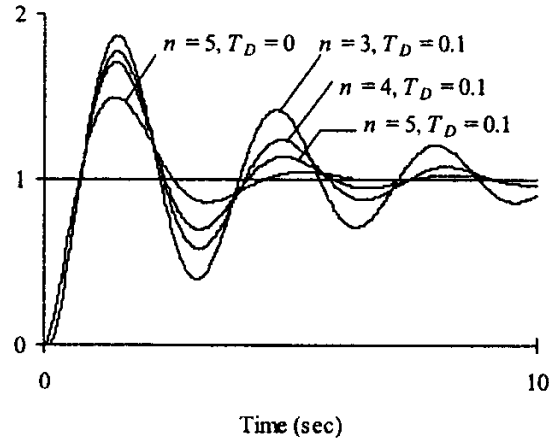

Fig. 9 Time response for $G(s) = e^{-sT_D} / Ms^2$ with $M = 1$, $T_D = 0$ and $T_D = 0.1$, under the control of a Letnikov-based approximation of $D^{1/2}$ with truncation orders of $n = 3, 4$ and 5 . The sampling period is $T = 0.1 \text{ sec}$ and the controller gain is $K = 10\sqrt{2/T}$.

Clearly, the higher the order of the series truncation the better the system performance and the closer the system response with and without time delay in the loop. It should be pointed out that the adoption of a $D^{1/2}$ controller is just for comparison purposes and, in fact, the development of systematic design procedures for FDI -based algorithms is currently under investigation.

6. PERFORMANCE OF FDI APPROXIMATIONS IN NONLINEAR CONTROL SYSTEMS

In order to investigate the robustness of the FDI -based control algorithms we introduced a nonlinear block in the forward path (Figure 10) and a system with a mass M .

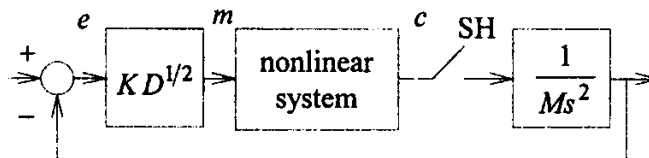

Fig. 10 A $D^{1/2}$ controller for a system with a mass M and a nonlinear actuator.

Four different phenomena in the actuator are considered for this system: saturation ($\mu = 1, \Delta = 1$), deadzone ($\mu = 1, \lambda = 0.1$), hysteresis ($\mu = 1, \lambda = 0.1$) and relay ($\gamma = 1$) with the characteristics depicted in Figure 11. In all the cases, the parameters adopted in the experiments are $K = 10 T^{1/2}$, $M = 1$ and a sample and hold time $T = 0.1$.

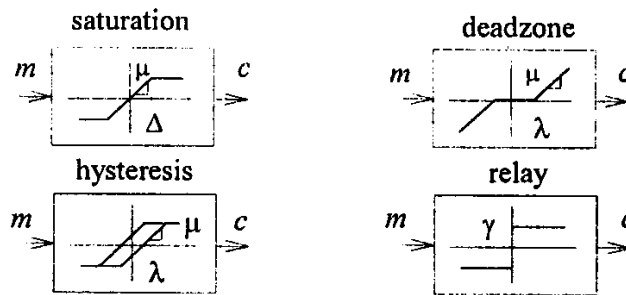

Fig. 11 Nonlinear phenomena at the actuator: saturation ($\mu = 1, \Delta = 1$), deadzone ($\mu = 1, \lambda = 0.1$), hysteresis ($\mu = 1, \lambda = 0.1$) and relay ($\gamma = 1$).

Figure 12 shows the linear system response (*i.e.* without the nonlinear block), for a unity step input and a n^{th} order ($1 \leq n \leq 7$) approximation to $D^{1/2}$ according with (9). It is clear that the higher the order of the approximation the better the response.

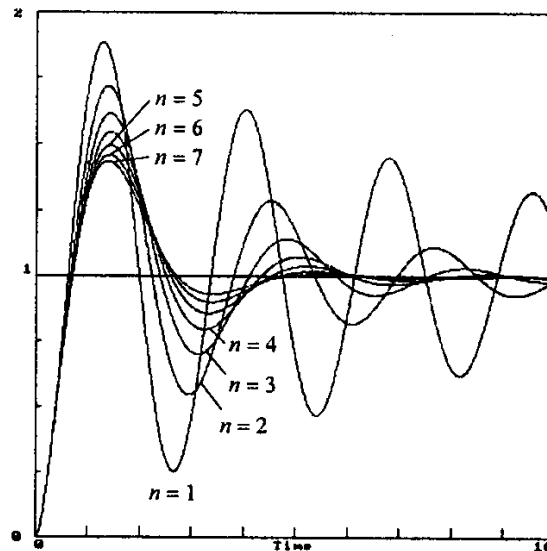

Fig. 12 Linear system response for a n^{th} order series approximation to $D^{1/2}$.

The robustness of the fractional algorithm over classical control actions is highlighted in the presence of a nonlinear actuator. Figure 13 shows that the response for the *FDI* controller with $n = 1$ is very sensitive to the saturation effect while for higher values of n becomes more stable. In the same line of thought, Figures 14, 15 and 16 reveal that the 7th order approximation to the $D^{1/2}$ controller is robust

for a large range of nonlinear phenomena, having a better performance the higher the order of series truncation.

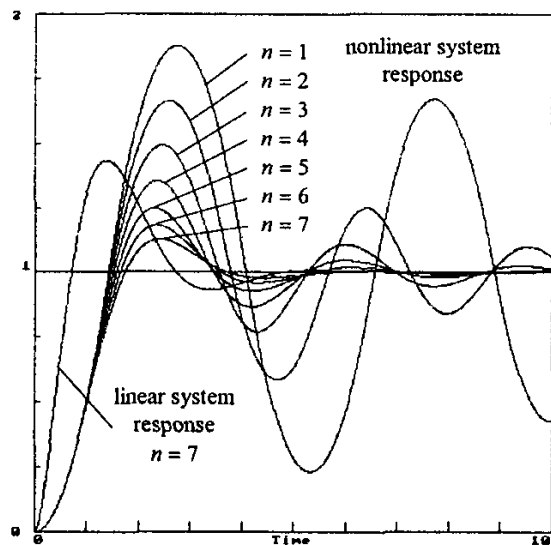

Fig. 13 System response, with saturation, for a n^{th} order series approximation to $D^{1/2}$

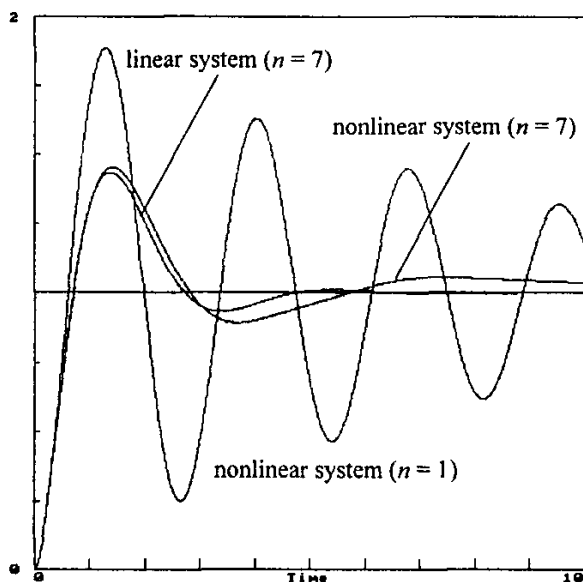

Fig. 14 System response, with deadzone, for a 7^{th} order series approximation to $D^{1/2}$

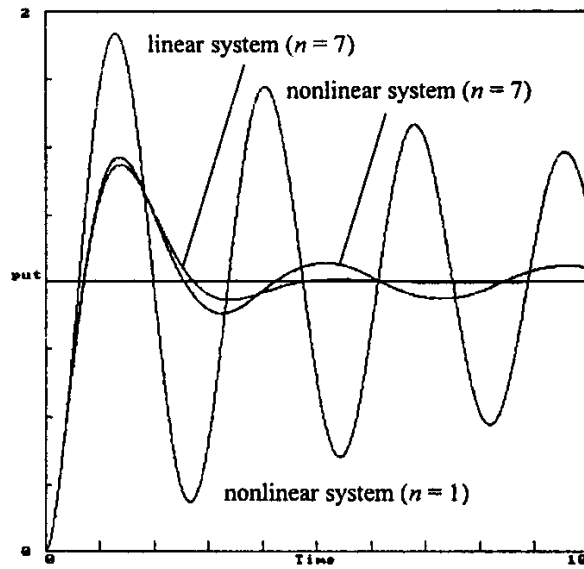

Fig. 15 System response, with hysteresis, for a 7th order series approximation to $D^{1/2}$.

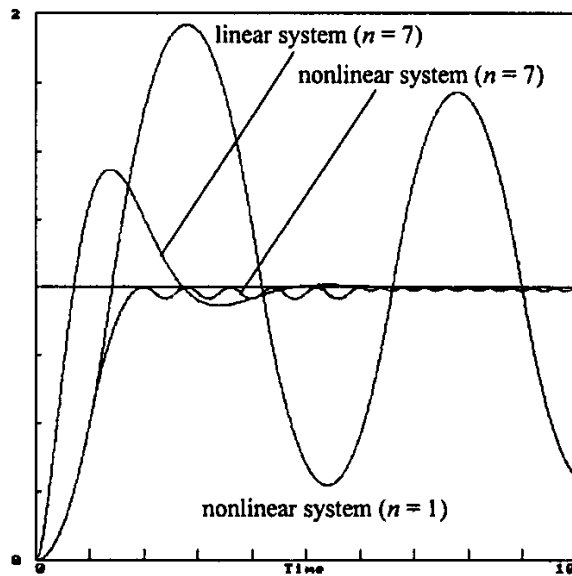

Fig. 16 System response, with relay, for a 7th order series approximation to $D^{1/2}$.

7. CONCLUSIONS

The recent progress in the area of chaos reveals promising aspects for future developments and application of the theory of fractional calculus. In the area of automatic control some preliminary work has been proposed but the algorithms are restricted to the frequency domain. In this paper several methods for the discrete-time *FDI* approximation were presented and compared. The new algorithms adopt the time domain, making them well adapted for z-transform analysis and computer calculation.

The properties of the Letnikov, Tustin and Simpson schemes are studied in terms of robustness and system stability, revealing that the first approach is preferable. For a simple prototype system the control algorithms based on the fractional-order concepts are simple to implement and reveal good robustness.

REFERENCES

- [1] Andrew Gemant, "On Fractional Differentials", *Philosophical Magazine*, vol. 25, pp. 540-549, 1938.
- [2] Keith B. Oldham and Jerome Spanier, "The Fractional Calculus: Theory and Application of Differentiation and Integration to Arbitrary Order", Academic Press, 1974.
- [3] Bertram Ross, "Fractional Calculus", *Mathematics Magazine*, vol. 50, no. 3, pp. 15-122, May 1977.
- [4] Stefan G. Samko, Anatoly A. Kilbas, Oleg I. Marichev, "Fractional Integrals and Derivatives: Theory and Applications", Gordon and Breach Science Publishers, 1993.
- [5] Kenneth S. Miller and Bertram Ross, "An Introduction to the Fractional Calculus and Fractional Differential Equations", John Wiley and Sons, 1993.
- [6] Thomas J. Osler, "Leibniz Rule for Fractional Derivatives Generalized and its Application to Infinite Series", *SIAM Journal of Applied Math.*, vol. 18, no. 3, pp. 658-674, May 1970.
- [7] Thomas Osler, "Taylor's Series Generalized for Fractional Derivatives and Applications", *SIAM Journal of Math. Analysis*, vol. 2, no. 1, pp. 37-48, Feb. 1971.
- [8] Bertram Ross (ed.), "Fractional Calculus and Its Applications", *Lecture Notes in Mathematics* 457, Springer-Verlag, 1974.
- [9] Katsuyuki Nishimoto, "Fractional Calculus (Volume IV): Integrations and Differentiations of Arbitrary Order", Descartes Press, Japan, 1991.
- [10] L. M. B. C. Campos, "Application of Fractional Calculus to the Generation of Special Functions with Complex Parameters", *Journal of Fractional Calculus*, vol. 4, pp. 61-76, Nov. 1993.
- [11] L. M. B. C. Campos, "Fractional Calculus of Analytic and Branched Functions", *Recent Advances in Fractional Calculus*, R. N. Kalia (ed.), pp. 66-43, Global Pub. Company 1993.
- [12] Stefan G. Samko and Bertram Ross, "Integration and Differentiation to a Variable Fractional Order, Integral Transforms and Special Functions", vol. 1, no. 4, pp. 277-300, 1993.
- [13] S. G. Samko, "Fractional Integration and Differentiation of Variable Order", *Analysis Mathematica*, vol. 21, pp. 213-236, 1995.
- [14] Andrew Gemant, "A Method of Analyzing Experimental Results Obtained from Elasto-Viscous Bodies", *Physics*, vol. 7, pp. 311-317, Aug. 1936.
- [15] Michael Stiassnie, "On the Application of Fractional Calculus for the Formulation of Viscoelastic Models", *Applied Math. Modelling*, vol. 3, pp. 300-302, Aug. 1979.
- [16] Ronald L. Bagley and Peter J. Torvik, "Fractional Calculus-A Different Approach to the Analysis of Viscoelastically Damped Structures", *AIAA Journal*, vol. 21, no. 5, pp. 741-748, May 1983.
- [17] Lynn Rogers, "Operators and Fractional Derivatives for Viscoelastic Constitutive Equations", *Journal of Rheology*, vol. 27, no. 4, pp. 351-372, 1983.
- [18] R. C. Koeller, "Applications of Fractional Calculus to the Theory of Viscoelasticity", *ASME Journal of Applied Mechanics*, vol. 51, pp. 299-307, June 1984.
- [19] P. J. Torvik and R. L. Bagley, "On the Appearance of the Fractional Derivative in the Behaviour of Real Materials", *ASME Journal of Applied Mechanics*, vol. 51, pp. 294-298, June 1984.

- [20] R. L. Bagley and P. J. Torvik, "On the Fractional Calculus Model of Viscoelastic Behaviour", *Journal of Rheology*, vol. 30, no. 1, pp. 133-155, 1986.
- [21] R. C. Koeller, "Polynomial Operators, Stieltjes Convolution, and Fractional Calculus in Hereditary Mechanics", *Acta Mechanica*, vol. 58, pp. 251-264, 1986.
- [22] J. Padovan, "Computational Algorithms for FE Formulations Involving Fractional Operators", *Computational Mechanics*, vol. 2, no. 4, pp. 271-287, 1987.
- [23] Chan Ghee Koh and James M. Kelly, "Application of Fractional Derivatives to Seismic Analysis of Base-isolated Models", *Earthquake Engineering and Structural Dynamics*, vol. 19, pp. 229-241, 1990.
- [24] R. L. Bagley and R. A. Calico, "Fractional Order State Equations for the Control of Viscoelastically Damped Structures", *ASME Journal of Guidance*, vol. 14, no. 2, pp. 304-311, March-April 1991.
- [25] Nicos Makris and M. C. Constantinou, "Fractional-Derivative Maxwell Model for Viscous Dampers", *Journal of Structural Engineering*, vol. 117, no. 9, pp. 2708-2724, Sept. 1991.
- [26] Nicos Makris, M. C. Constantinou and G. F. Dargush, "Analytical Model of Viscoelastic Fluid Dampers", *Journal of Structural Engineering*, vol. 119, no. 11, pp. 3310-3325, Nov. 1993.
- [27] L. Gaul and C. M. Chen, "Modeling of Viscoelastic Elastomer Mounts in Multibody Systems", *Advanced Multibody System Dynamics*, W. Schiehlen (ed.), pp. 257-276, Kluwer Academic Publishers, 1993.
- [28] M. C. Constantinou and M. D. Symans, "Experimental Study of Seismic Response of Buildings with Supplemental Fluid Dampers", *The Structural Design of Tall Buildings*, vol. 2, pp. 93-132, 1993.
- [29] L. Gaul and M. Schanz, "Dynamics of Viscoelastic Solids Treated by Boundary Element Approaches in Time Domain", *European Journal of Mechanics, A/Solids*, vol. 13, no. 4 – suppl., pp. 43-59, 1994.
- [30] Nicos Makris, G. F. Dargush and M. C. Constantinou, "Dynamic Analysis of Viscoelastic-Fluid Dampers", *Journal of Engineering Mechanics*, vol. 121, no. 10, pp. 1114-1121, Oct. 1995.
- [31] Åsa Fenander, "Modal Synthesis when Modeling Damping by Use of Fractional Derivatives", *AIAA Journal*, vol. 34, no. 5, pp. 1051-1058, May 1996.
- [32] B. S. Liebst and P. J. Torvik, "Asymptotic Approximations for Systems Incorporating Fractional Derivative Damping", *ASME Journal of Dynamic Systems, Measurement, and Control*, vol. 118, pp. 572-579, Sept. 1996.
- [33] J. P. Clerc, A.-M.S. Tremblay, G. Albinet, C.D. Mitescu, "A. C. Response of Fractal Networks", *Le Journal de Physique-Lettres*, vol. 45, n. 19, pp. L.913-L.924, Oct. 1984.
- [34] S. H. Liu, "Fractal Model for the ac Response of a Rough Interface", *Physical Review Letters*, vol. 55, n. 5, pp. 529-532, July 1985.
- [35] Theodore Kaplan, L. J. Gray and S. H. Liu, "Self-Affine Fractal Model for a Metal-Electrolyte Interface", *Physical Review B*, vol. 35, n. 10, pp. 5379-5381, April 1987.
- [36] Alain Le Méhauté, "Fractal Geometries: Theory and Applications", Penton Press, 1991.
- [37] Thomas J. Anastasio, "The Fractional-Order Dynamics of Brainstem Vestibulo-oculomotor Neurons", *Biological Cybernetics*, vol. 72, pp. 69-79, 1994.
- [38] A. Oustaloup, "Fractional Order Sinusoidal Oscillators: Optimization and Their Use in Highly Linear FM Modulation", *IEEE Trans. on Circuits and Systems*, vol. 28, n. 10, pp. 1007-1009, Oct. 1981.
- [39] J. R. M. Hosking, "Fractional Differencing", *Biometrika*, vol. 68, no. 1, pp. 165-176, 1981.

- [40] Haldun M. Ozaktas, Orhan Arikan, M. Alper Kutay and Gözde Bozdagi, "Digital Computation of the Fractional Fourier Transform", *IEEE Transactions on Signal Processing*, vol. 44, no. 9, pp. 2141-2150, Sept. 1996.
- [41] Manuel D. Ortigueira, "Fractional Discrete-Time Linear Systems", *ICASSP'97-IEEE International Conference On Acoustics, Speech and Signal Processing*, Munich, Germany, 20-24 April 1997.
- [42] D. Dubois, J.-P. Brienne, L. Pony and H. Baussart, "Study of a System Described by An Implicit Derivative Transmittance of Non Integer Order With or Without Delay Time", *IEEE-SMC/IMACS Symposium on Control, Optimization and Supervision*, pp. 826-830, Lille, France, 1996.
- [43] R. R. Nigmatullin, "The Realization of the Generalized Transfer Equation in a Medium with Fractal Geometry", *Phys. stat. sol. (b)*, vol. 133, pp. 425-430, 1986.
- [44] A. Le Méhauté, F. Héliodore, D. Cotteville and F. Latreille, "Introduction to Wave Phenomena and Uncertainty in a Fractal Space", *Chaos, Solitons & Fractals*, vol. 3, no. 5, 1993.
- [45] Francesco Mainardi, "Fractional Relaxation in Anelastic Solids", *Journal of Alloys and Compounds*, 211/212, pp. 534-538, 1994.
- [46] Francesco Mainardi, "Fractional Relaxation-Oscillation and Fractional Diffusion-Wave Phenomena", *Chaos, Solitons & Fractals*, vol. 7, no. 9, pp. 1461-1477, 1996.
- [47] Itzhak Webman, "Propagation and Trapping of Excitations on Percolation Clusters", *Journal of Statistical Physics*, vol. 6, n. 5/6, pp. 603-614, 1984.
- [48] Denis Matignon and Brigitte d'Anréa-Novel, "Some Results on Controllability and Observability of Finite-Dimensional Fractional Differential Systems", *IEEE-SMC/IMACS Symposium on Control, Optimization and Supervision*, pp. 952-956, Lille, France, 1996.
- [49] Benoit Mathieu, Ludovic Le Lay and Alain Oustaloup, "Identification of Non Integer Order Systems in the Time Domain", *IEEE-SMC/IMACS Symposium on Control, Optimization and Supervision*, pp. 952-956, Lille, France, 1996.
- [50] A. Le Méhauté, "From Dissipative and to Non-dissipative Processes in Fractal Geometry: The Janals", *New Journal of Chemistry*, vol. 14, no 3, pp. 207-215, 1990.
- [51] Alain Le Méhauté, "Transfer Processes in Fractal Media", *Journal of Statistical Physics*, vol. 36, no 5/6, pp. 665-676, 1984.
- [52] A. Oustaloup, "La Commande CRONE: Commande Robuste d'Ordre Non Entier", *Hermes*, 1991.
- [53] A. Oustaloup, B. Mathieu and P. Lanusse, "The CRONE Control of Resonant Plants: Application to a Flexible Transmission", *European Journal of Control*, vol. 1, no. 2, pp. 113-121, 1995.
- [54] J. A. Tenreiro Machado, "Analysis and Design of Fractional-Order Digital Control Systems", *SAMS-Journal Systems Analysis, Modelling, Simulation*, vol. 27, pp. 107-122, 1997.
- [55] J. A. Tenreiro Machado and Abílio Azenha, "Position/Force Fractional Control of Mechanical Manipulators", *IEEE Int. Workshop on Advanced Motion Control*, Coimbra, Portugal, 1998.