

# ISEPORTO ROBOTIC SOCCER TEAM: A NEW PLAYER GENERATION

V. Cerqueira\*, André Dias<sup>+</sup>, Nuno Matos<sup>+</sup>, J. M. Almeida\*, A. Martins,\* E. P. Silva\*

*LSA -Autonomous Systems Lab  
Instituto Superior de Engenharia do Porto  
R. Dr. António Bernardino de Almeida 431  
4200-072 Porto, Portugal*

\*{ vitor,jma, amartins, eaps}@dee.isep.ipp.pt  
+{andre,nuno}@lsa.isep.ipp.pt

**Abstract:** This paper describes the recent modifications in ISePorto MSL robotic football team and future improvements concerning the development and evolution of the team. The robot was substantially redesigned in order to achieve high reliability, allow better control and coordination capabilities and substantial increase in perception. New mechanical and hardware redesign is presented. Motion control subsystems, new vision hardware sensor and overall architecture are described. The team redesign is done for preparation for participating in the Robocup 2004. The main goal is to achieve not only an important evolution in the team control and coordination but also increased overall reliability.

**Keywords:** mobile robotics, robot architectures, mechanical robot design, robotic soccer, robocup

## 1. INTRODUCTION

The ISEP Autonomous Systems Lab. (LSA) robotic football team provides an excellent tool to develop and demonstrate the research in the areas of interest associated with autonomous systems. These are mainly sensor fusion, mobile robotics navigation, nonlinear hybrid feedback control, system architectures, and coordination of teams of robots in dynamic environments. Additionally to the research interests, the laboratory has a strong educational purpose, being the robot team a good support to curricular and extra-curricular work in the areas of mechatronics, electronics and embedded systems.

In this paper we will focus in the description of hardware developments in ISePorto MSL robotic football team concerning the participation in the Robocup 2004.

The team objectives for this competition are development of an integrated control and navigation architecture and advanced integrated team coordinated game play. Our approach relies in the efficient use of the distributed robot resources not only by a top coordination layer but to use multiple robots in different layers of control and navigation [1],[2].

An additional goal is to improve significantly the team reliability during games

In terms of team cooperative play new control capabilities are required with advanced overall robot and ball control is required. These leads to a

mechanical redesign made in the current structure of robots, increasing its mobility. The new kicker will be also capable of rotation. Additionally it will have lower weight, reduced inertia (through a better mass distribution) and with a ball kicking force control and stopping mechanism. It will also comprise retractable ball guides.

New distributed low-level motion control architecture is implemented with higher computational power, increased motion sensing thus allowing advanced control algorithms.

Multiple robot coordination also requires better perception

Image latency and lack of determinism problems led to the development of a new dedicated hardware vision system. This system allows not only the reducing of latency and determinism but also reduces main CPU load, higher resolution, and higher frame rate.

Reliability requirements led also to the implementation of the axis control nodes connected in an industrial serial bus (CAN) [3], thus reducing the operational failures due to bad electrical connections, and global cabling complexity.

The remaining of the paper overviews the design options taken in the development. Mechanical are described next followed by the presentation of the new computational system architecture. In section 5 low level motion control modules are addressed and the software development system is treated in section 6. Prior to the final conclusions the vision

system is addressed with particular emphasis to the development of the new hardware intelligent vision sensor.

## 2. DESIGN OPTIONS

The robot team [4] was designed and implemented from scratch in order to constitute a suitable test bed for advanced multi-robot coordinated control. The mechanical design has taken in account the requirements to execute complex maneuvers and therefore does not poses hard constraints on the development of control, navigation, or coordination procedures. These requirements underlie the design of an innovative rotating kicker and the option to use two pan-controlled cameras.

The vehicles (see Fig. 1) have differential locomotion. An omni-directional locomotion scheme was not considered due to its low traction efficiency that strongly limits its application to very regular surfaces such as indoors. The additional degree of freedom provided by the kicker allows complex playing behaviors and pose interesting research problems.

The option for rotating cameras instead of omni-directional vision was due to its limitations in the quality of measurements for long distances, such as in outdoor problems, and larger play fields. Robocup rules and objectives tend to define increasing field sizes in order to achieve the final goal of playing in a human sized football field.

In terms of perception, the two wide angle paned cameras (one in a rotating head and the other fixed to the kicker structure provide bearing and range relatively to fixed landmarks (goals and corner poles), and moving targets (ball, opponent robots, team robots). The range measurements are very sensitive to vehicle oscillations, and depend strongly on the vision system accuracy, providing worse information than that of bearing measurements.

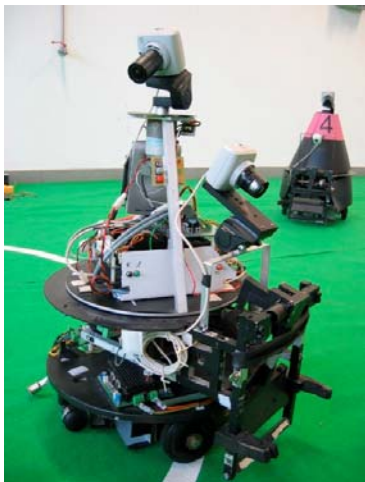

Fig. 1. ISePorto Team robots exhibiting two rotating cameras and rotating kicker.

## 3. ROBOT STRUCTURE

The original robot (see Fig.2. left) has three parts: a circular mobile base, a kicker connected to a structure that rotates around a central vertical axle, and on top, a computational an electronics module fixed relatively to the base with a pan mounted camera.

The system is mechanically modular; it can be used in different configurations, such as different kicker designs with the same base. The base contains two differential traction 24 V DC motors with optical encoders for motor control and vehicle odometry, two 12V NiMH packs with 6Ah, the kicker rotation motor and the motor power drives boards.

Motivated by the objective of having a team capable of performing ball passes, the development of a new kicker device provides the following functionalities: kicking power control, ball retractable guides and ball reception device. While the first is required for the pass with a low power in order for the other robot be able to intercept and perform the ball reception, the second is required to increase the reception angle allowing additional playing maneuvers. And at last, the reception device provides a way for slowing the ball at the reception instant.

Additionally, recent Robocup MSL rules changes motivate reducing the overall robot base area to allow playing with increased number of robot in the team.

Those consideration have motivated a robot redesign meeting the following requirements:

- keep a rotating kicker,
- partial mechanic compatibility with old design (lowering manufacturing costs),
- reduced robot base area,
- kicker with: ball force control (mechanical spring with different stop positions), ball stopping mechanism, retractable ball guides and reduced inertia,
- optimized cameras positioning in order to improve the perception,
- increased available volume for computational parts.

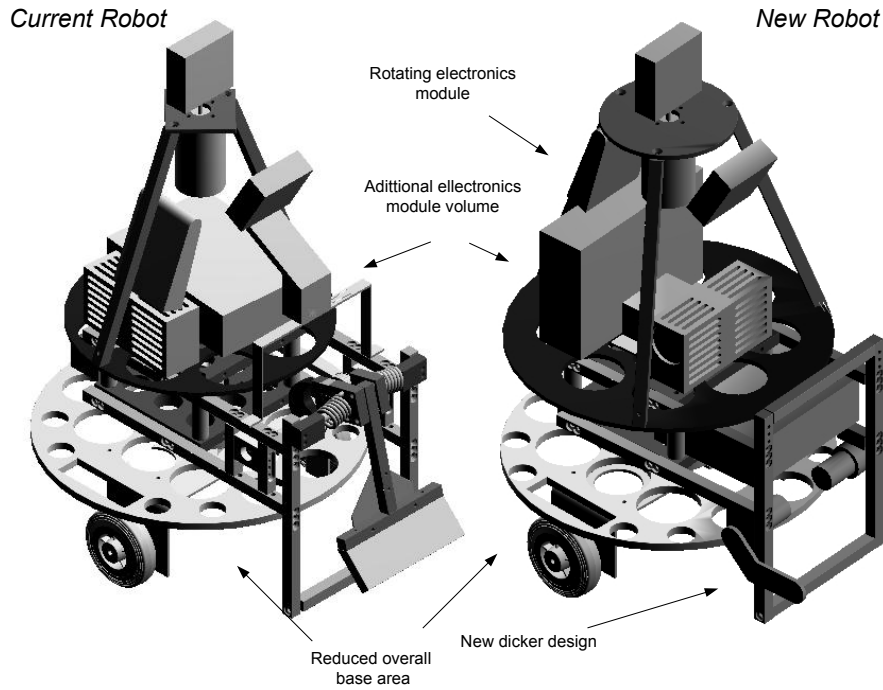

Fig. 2. The current and new robots design of ISePorto team.

The new mechanical solution can be observed in Fig. 2 on the right. The upper volume containing the main electronics and CPU now rotates with the kicker. The base diameter was reduced and a new mount for the kicker camera was developed. Allowing the kicker camera to be inside the upper protective cone, resulting in an improved ball and landmarks coverage.

The set of cables subjected to torsion now resides inside the main center axle and are less subjected to rupture compared with the original design (being also less in number). The new kicker design has better weigh distribution, taking advantage of the available space.

Improved electronics and cameras ball impact protection is also achieved by the mechanic structure.

Some of the problems arising from the actual high rotating inertia in the kicker are reduced by the achieved decrease in inertia from 195 g.m<sup>2</sup> to 160g.m<sup>2</sup> for the new rotating module.

One of the shortcomings of the current design is the inadequate ball coverage by the cameras. In particular for the head camera that can not see the ball when it is close to the robot.

Camera positioning (Fig. 3) is conditioned by the mechanical design (in terms of available space and mounting limitations), by the lens focal point and vertical field of view (50.5° for head camera), robot base diameter and rules vertical limit.

In the new robot it was possible to move the head camera lower achieving ball coverage even with the ball near the robot with smaller diameter.

Ball coverage can be measure by distance  $p$  and is related with the other parameters by:

$$p = ((h - R)\tan\alpha - D_{ball\_robot})\cos\alpha \quad (1)$$

with unavailable coverage for situations with  $p > R$ .

The additional volume available in the upper robot section, coupled with the new mounting, allows the integration and test of earlier hardware vision sensor prototypes.

#### 4. COMPUTATIONAL SYSTEM ARCHITECTURE

The main computational system consists of a 5.25" SBC (ICP NOVA7896FW with a 900Mhz Celeron) and IDE 24Mb Flash disk. Each robot communicates with the team and the host visualization computer by an Ethernet wireless modem compliant with IEEE 802.11b.

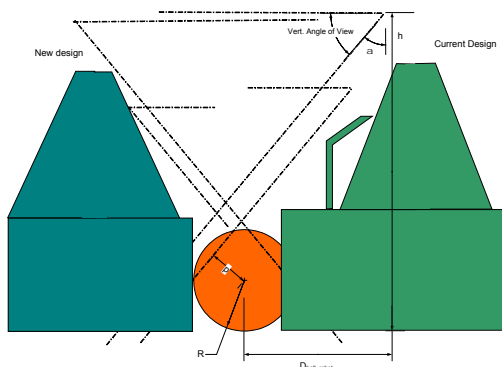

Fig. 3. Ball camera coverage (for head camera)

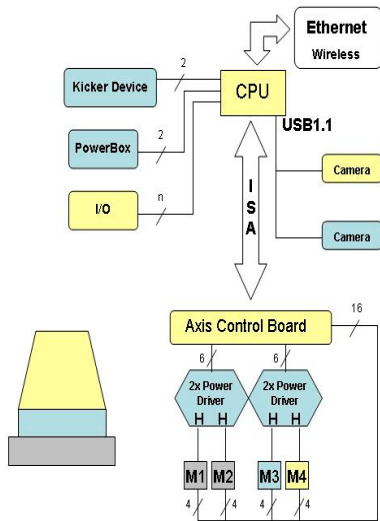

Fig. 4. ISePorto - An overview of the current robot system

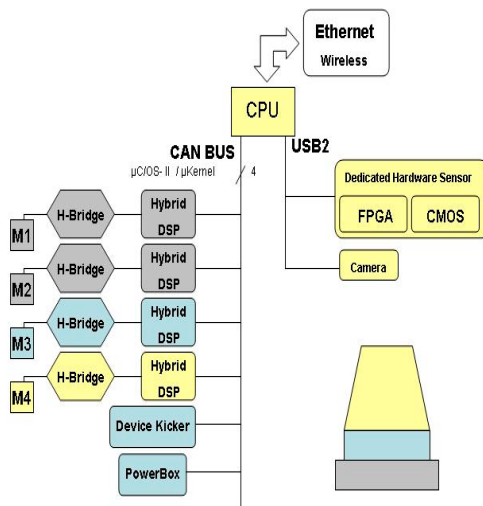

Fig. 5. ISePorto - An overview of the new robot system

In figures 4 and 5 a diagram of the two robot hardware configurations can be observed. The new distributed architecture with multiple nodes in a CAN bus reduces significantly the cabling and thus improving overall system reliability. Interface with the vision sensors is done by USB 2 maintaining a standard and increasing available bandwidth. This extra bandwidth can be used to increase resolution in standard USB cameras or to allow a combination of the new hardware dedicated intelligent vision sensors under development.

## 5. MOTION CONTROL

In the new hardware design axis control is performed by distributed modules with integrated power drives. The integration of the motor controller H-bridges with the low level motion

control modules provides additional modularity, reducing cabling problems and removed the requirement for the ISA bus communication with the axis control board. Since currently ISA is being deprecated in many CPU boards the use of CAN gives extra versatility (since CAN interfaces can be obtained for different standard CPU communication interfaces such as PCI, parallel, ISA or even serial).

Using this new approach we can avoid some problems of the current axis control board such as:

- low processing capability disabling the implementation of complex control algorithms;
- Cable complexity and resulting problems of reliability;
- ISA interface and old technological solutions can become obsolete and starts conditioning robot evolution;
- impossibility of implementing torque control motion algorithms, leading to poor traction control (with implications in odometry);
- difficult to maintain and tune motion control firmware due to the difficulty of implementing floating point calculations.

The development took in mind the reducing of the number of cables, providing torque measurements for traction control, small size, low power, and providing computational capabilities supporting relatively sophisticated control algorithms.

The combination of the integrated MC33887 5.2A H-bridge [8] with current sensing and the Motorola DSP56F8322 16bits hybrid DSP [7] with integrated CAN bus, encoder interface, ADC, and an high level development system provides a good solution meeting all the requirements.

## 6. DEVELOPMENT SYSTEM

The onboard main embedded computer runs a Linux operating system from the flash disk. For development convenience, we use a root filesystem over NFS.

A specific distribution was developed for the vehicles and a standard Linux kernel (2.4.19) was modified in order to provide some real-time functionalities and additional development tool support. These modifications include the following patches: high resolution clocks, pre-emptive kernel and Linux Trace Toolkit support.

The software design follows a modular and hierarchic multi-threaded software architecture [4]. We use the Posix [6] soft real time extensions: a priority pre-emptive scheduler and all the application memory resources are prevented from swapping to disk with *mlock()*. The robots use developed software API for communication by IP datagrams in a broadcast or multicast configuration.

Distributed perception requires clock synchronization for information tagging. Network Time Protocol (NTP) [5] is used to synchronize

robot system clocks allowing a maximum offset of 500  $\mu$ s during each game play.

There have been developed graphical tools for visualization of robot state and perceived sensor information, camera parameters and colour segmentation adjustment, and user interface for robot operation.

## 7. VISION SYSTEM

The current vision system uses two USB [9] cameras (Philips PVC740K) placed in a new housing that interface a CS-mount wide angular lens (a 2.8mm, F1.4, maxvision MVL2810M). Both cameras acquire images at 30fps, the head camera with a resolution of 320x240 and the kicker camera with a resolution 160x120. The image processing threads are capable to process all the acquired images. This processing is mainly done in a colour-segmented image.

The colour segmentation algorithm uses a pre-determined set of regions in the YUV in order to detect the game relevant colours. The colour segmentation algorithm implementation follows a very efficient method proposed in [12]. This process is still very sensitive to lighting conditions. Some problems with overlapping regions are noticed in the cases of colour that form a cluster diagonal to the YUV limit box. In order to improve the segmentation for colours within a diagonal cluster this is bounded by a set of boxes in YUV. All this process of colour segmentation can be very difficult to do without a good tool. Additionally, the problem can be even harder if we add all the camera parameters (shutter speed, gain, and white balance: red and blue, brightness, etc). In practice, we have a well-established set of colour limits and normally adjust the camera parameters until have a good segmentation. After that, we can adjust some colour limits to further improve the colour segmentation.

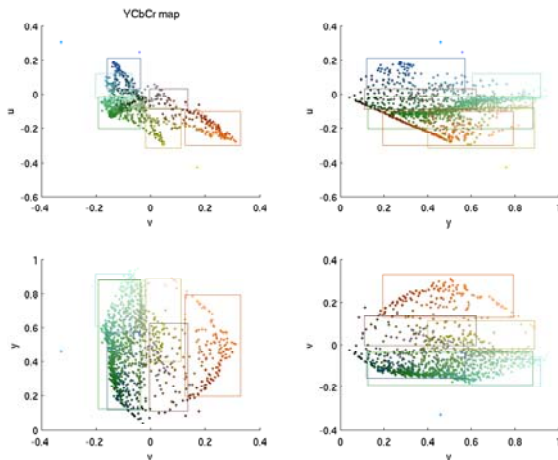

Fig. 6. Example of a YUV colour map and segmentation colours limits, visualised by the colour segmentation graphical tool.

The landmarks and world objects perceived by the vision system are the ball, Corner flags, Goals (Limits and Areas), Team colour marks and dark Obstacles. The ball, robots marks, dark objects and blue and yellow objects are detected using a blob-based algorithm. This provides information regarding ball centroid and bounding box for all possible clusters. The corner and goals objects are also validated along specified scan lines. A hierarchical approach is taken to eliminate false detection.

Due to wide angular characteristics of the lens used (needed for convenient field of view) the image received has some distortion. This taken in account in the scan lines. For example: a horizontal line (see the white line in the top of the Fig. 7) is computed in the distorted space, and the result is used in the scan. The information obtained in the distorted space is then converted to a corrected image coordinates and then to camera referential. The advantage of the use of this scan line is twofold. First, the angle to some target obtained this way becomes less sensitive to camera oscillations. Second, this scan allows a fast search for target candidates with the guaranty that if they are in the field of view they must intercept the horizontal plane where the search is conducted.

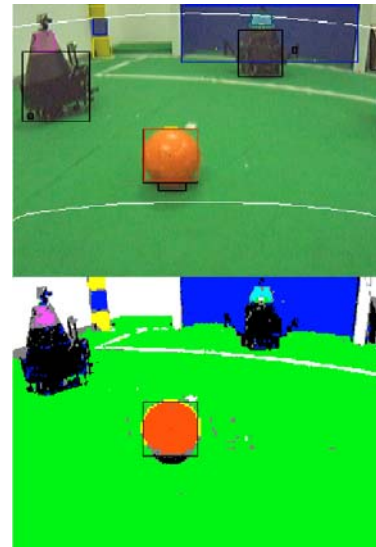

Fig. 7. Original and color segmented images. Over the images we can see the Horizontal scan line in the original images (head camera, marked in white on top image), the Ball limits represented by a black box around the ball. Additionally, blob limits can be seen in the top image.

A major improvement in our vision system is been currently developed by our team and consists of an intelligent vision sensor [10], [11], [15].

The sensor will allow the implementation of the above described steps (image acquisition, color segmentation, object classification) in reconfigurable hardware, thus providing relevant

performance increase and reduced main CPU load. This work has been carry out in the context of the Project “BoaVista - A Dedicated Vision System for Autonomous Mobile Robots Navigation” funded by Portuguese Foundation for Science and Technology. This vision system uses the LM9647 National 1/4" CMOS image sensor [14] capable of 68fps at 640x480 resolution or higher frame rates at lower resolutions. Relevant features are the progressive scan and programmable windowing among others.

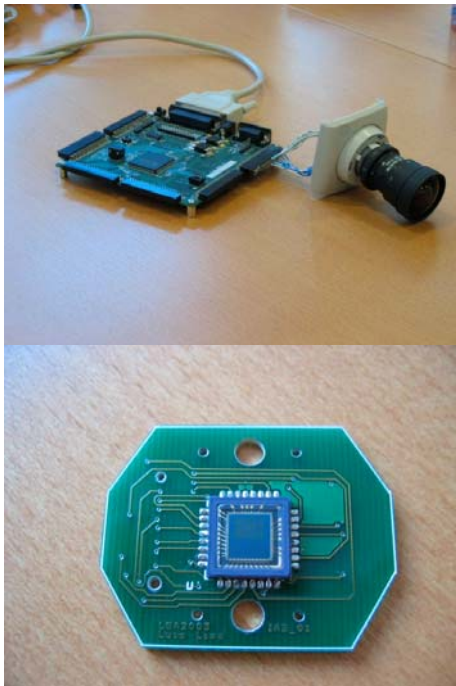

Fig. 8. Intelligent vision sensor

Thus this sensor becomes a good candidate to be the base of an intelligent vision system for mobile robots.

The images frame pixels from this sensor are segmented and color classified, compressed in RLE segments and grouped in color blobs by an FPGA device, that perform those task in a filter like form. The results are communicated to the central robot processor by serial or parallel port and will be in near future by USB bus. A more detailed description of this system can be found in [15].

Although, not yet integrated with the overall system, since we are now using the same type of image processing in our robots software (both for validating the method, and providing the specification and dimensioning of the hardware system under development), the final integration shouldn't bring significant additional work.

## 8. CONCLUSIONS AND FUTURE WORK

Current developments in the design of the robot player for the ISePorto Robotic Soccer Team are presented.

An emphasis is taken on new mechanical and hardware redesign. Problem requirements are analyzed and experience gained with operation of current robots in international competitions is used in the new developments.

The main ISePorto goal of achieving integrated cooperative game playing lead to the design of a new ball kicker mechanism, new motion control subsystems and the development of a dedicated intelligent hardware based vision sensor.

The dedicated hardware vision sensor currently being developed allows decrease of image latency and provides much higher precision in the raw vision measures.

These developments allow the implementation of coordinated attack and defense maneuvers [ref symposium].

The team has participated in several competitions namely in the Robocup 2003 in Padua, German Open 2002 and 2003, Robótica 2002 and Robótica 2003 in Portugal, with good results

The test of the new integrated hardware features and the integrated navigation and control approach needs to be validated in game conditions in Robocup 2004 competition.

## ACKNOWLEDGEMENT

The authors would like to thank the LSA team for their efforts and dedication in developing the robots and support on the participation of competitions and events. This work is sponsored by IPP, ISEP, Salvador Caetano and Bosch Security systems.

The BoaVista Project is founded by the Portuguese Science and Technology Foundation of Ministry of Science and Technology.

## REFERENCES

- [1] J. M. Almeida, F. L. Pereira and J. B. Sousa, “A Hybrid Feedback Control System for a Nonholonomic Car-like Vehicle, ” *International Conference on Robotics and Automation*, Albuquerque, New Mexico, 1997
- [2] J. M. Almeida, A. Martins, E. Silva and F. L. Pereira , “An Approach to Simultaneous Control Navigation and Target Tracking for Robotic Formations, ” *submitted to Robocup 2004 Symposium*, Lisbon, Portugal 2004
- [3] Wolfhard Lawrenz, *CAN System Engineering – From Theory to Pratical Applications*, Springer-Verlag, 1999
- [4] J. M.Almeida, A. Martins, E. P. Silva, et. al, “ISePorto Robotic Soccer Team for Robocup 2003. TDP RoboCup-2003, “ *Robot Soccer World Cup VII*, LNCS series, Springer-Verlag, 2004
- [5] Mills, D.L. Adaptive hybrid clock discipline algorithm for the Network Time Protocol. *IEEE/ACM Trans. Networking* 6, 5 (October 1998), 505-514.
- [6] Bill O. Gallmeister, *Programming for the Real World - Posix 4* , O'Reilly, 1995.
- [7] Motorola Inc., Datasheet MC56F8322, 2003.
- [8] Motorola Inc. , Datasheet MC33887, 2003.

- [9] Don Anderson, Dave Dzatko, *Universal Serial Bus System Architecture*, Second Edition, MindShare Inc.
- [10] A. Rowe, C. Rosenberg, I. Nourbakhsh, "A Low Cost Embedded Color Vision System", *Proceedings of IROS2002*, 2002.
- [11] J Johan Andrén-Dinerf, Lars Asplund, Carl Benson, Henrik Bergkvist, Mattias Brunk, "Chip Vision: A Vision System for Robots Based on Reconfigurable Hardware", *Robot Soccer World Cup VII*, LNCS series, Springer-Verlag, 2004.
- [12] J. Bruce, T. Balch, M. Veloso, "Fast and Inexpensive Color Image Segmentation for Interactive Robots," *IEEE/RSJ International Conf. On Intelligent Robots and Systems*, Vol 3, pp. 2061-2066, 2000
- [14] National Semiconductor Inc., " LM9647 – Color CMOS Image Sensor VGA 68 FPS," <http://www.national.com/pf/LM/LM9647.html>, 2003
- [15] L.Lima, J. M. Almeida, A.Martins, A. Patacho, E. P. Silva, "Sistema de visão robótica aplicado à equipa de futebol robótico ISePorto," *submitted to Robótica 2004*, Porto, Portugal.