



29th International Conference on Flexible Automation and Intelligent Manufacturing
(FAIM2019), June 24-28, 2019, Limerick, Ireland.

Improvement and validation of Zamak die casting moulds

H. A. Pinto, F. J. G. Silva*, R. P. Martinho, R. D. S. G. Campilho, A. G. Pinto

ISEP – School of Engineering, Polytechnic of Porto, Rua Dr. António Bernardino de Almeida, 431, 4200-072 Porto, Portugal

Abstract

The automotive industry, like many other industries, uses a wide range of parts produced by the die-cast process. Parts like engine blocks, wheel spacers, alternator housings and command cable terminals, are made by die casting with different kinds of materials like aluminium and zinc alloys. Despite being a reliable process both in terms of quantity and quality, it is very important to keep the process parameters controlled, in order to achieve a minimum percentage of defective parts, which may be caused by several factors such as, porosities, segregations, incomplete fill, soldering, cracks, etc. The main goal of the die casting industry is to achieve the zero per cent defects target, a goal that goes along with the automotive industry and its quality system, and to accomplish this objective the stakeholders need to invest in research and development. In the casting industry, for instance, it is very important to have a complete knowledge of the entire process developed inside the casting machine, from the melting pot to the die, in order to obtain data so one can improve the filling parameters, machine parts, and moulds. The focus of the presented study is the improvement of the methodologies used to design moulds for control cable terminals in Zamak alloys. The work starts by characterizing the flow happening inside the mould at the moment of cavity fill by analysing computer fluid dynamics simulations (CFD). The study proceeds by quantifying the porosities detected on cut terminal surfaces, and the ultimate goal is achieved with the modification of molten metal flow systems, like channels and sprues, and the introduction of venting systems, with a resource to mathematical and geometrical calculus developed in MATLAB[®] specifically for that purpose. The paper ends with the validation of the improvements, by comparing the initial results with the ones obtained through an improved mould, building bases for novel design concepts of moulds for this kind of parts, as well as new studies trying to improve the results now achieved.

© 2019 The Authors. Published by Elsevier B.V.

This is an open access article under the CC BY-NC-ND license (<http://creativecommons.org/licenses/by-nc-nd/4.0/>)

Peer-review under responsibility of the scientific committee of the Flexible Automation and Intelligent Manufacturing 2019 (FAIM 2019)

Keywords: Die casting, Zamak alloys, Moulds, CFD, Computing Fluid Dynamics, Design of moulds, Gas exhaust, Simulation.

* Corresponding author. Tel.: +351 228340500; fax: +351 228321159.
E-mail address: fgs@isep.ipp.pt

1. Introduction

The quality requirements on today's industry imply that improvements be made continuously, in order to eliminate production constraints that come up during manufacturing processes. Many of these quality requirements are based on Lean methodology which consists of various tools in order to ensure successful implementation. Tools like 5s, SMED or PDCA cycle which comprise the Ishikawa's diagram are frequently used in the productivity improvement of assembly lines [1]. Nowadays, companies within the automotive industry face an environment of tremendous competition that forces them to continuously adapt. The automotive sector, is on the top industries that requires excellence, applying continuous improvements on the products and processes of all vehicle components produced, placing this industrial sector at the forefront of development and allowing vehicles to be developed more rapidly, meeting as well the social requirements for reducing greenhouse gas emissions, pollution noise, increased safety, and energy efficiency, without detriment to performance nor cost inflation [2]. Each of these principles has its way of developing through the use of electronics, new ecological materials or manufacturing processes, contributing to the technological development, and going through a path that is very likely to reach in the near future, the autonomous car, taking advantage of new technologies such as the internet and cloud computing [3]. Because quality is a major key factor in meeting all the requirements imposed by the automotive sector, the introduction of questionable products should dictate ethical conduct and responsible action. To this end, the development of low-quality products not only brings a bad reputation for the company that produces them but can also ultimately lead to monetary and trust losses, legal proceedings and increased regulation governmental organizations [4]. Suppliers must, therefore, comply with the agreed requirements, such as delivery times, and quality parameters imposed by product engineering, in order to keep up with the assembly and construction scales, making product complies with the specifications of the main technical office. The need for high standards of quality imposes on companies the obligation to implement philosophies and management models, in which the most well-known nowadays, is the TQM model (Total Quality Management), which involves all individuals in an organization, continuous improvement of quality and customer satisfaction [5]. The implementation of an effective Total Quality Management system, supported by Lean and TPS ideologies, seems to be essential for the company's ability to maintain its competitiveness [6]. Starting on the tiniest bolt to the major engine component, a wide range of parts can be found that follow the quality control and improvement process, one of this parts are the control cable terminals, made in zinc-aluminium alloy named Zamak.

Control cables, also known as Bowden cables, are flexible mechanical elements of energy transmission between two or more devices [7,8]. They usually relay on a wire cable working in the interior of another one for conduction [9]. Command cable is, therefore, a system where all the components are necessary to carry out the process of conversion of mechanical energy, that is, the energy that can be transferred through a man-exerted force, translating into two forms of energy, motion-related kinetics, and storage-related potential [10]. The control cables can be found in cars' doors, seat adjustment, and acceleration, clutch and braking systems [11,12]. The use of this type of systems brings the advantage of adopting different layouts, between the place where the load is applied and the place or places where the effect is intended to be exerted. The path between two or more terminals may adopt different configurations and not having the need to have an exclusively straight course, using its application, when it is intended to overcome barriers such as mechanisms and parts placed in complex locations between the ends of the cable [13]. The type of actuation of the control cables is divided into two types of developed systems: the initial Pull system, and the Push-Pull system [14]. It is, therefore, possible to find a huge range of options, according to the requirements of the project and the option of the designer. Blocking terminals, are components that are coupled to the ends of the control cables, and designed with certain configurations, that allow their attachment to the places where the transfer of energy and work execution is desired. However, for the real case of door handles in the automotive industry, the materials commonly used in its manufacture are Zamak alloys and other die casting alloys. Die casting is a manufacturing technique used to produce geometrically complex metal parts, and the automotive industry is one of the main markets for parts obtained by this process [15], in which the molten material is injected directly onto a cable, thus eliminating operations, such as pressing. Die casting applies hydraulic energy that creates pressures which normally ranges from 70 to 3500 bar, the equivalent to 7 and 350 MPa, respectively [16].

The use of Zamak alloy brings the advantage of a good resistance to corrosion, due to their composition based on zinc and aluminum (Zn-Al), promoting the first element, zinc (Zn), a good protection, and the second, aluminum

(Al), the ability to form a surface layer of oxides, which prevents the progression of corrosion to the remaining material [17].

The dimensions of the locking terminals vary depending on the diameter of the metal cable and the requested stresses and must obey a minimum thickness between the most peripheral point of the cable and the wall of the terminal, in order to avoid breakage when requested. It is also paramount for the resistance of the assembly, the knowledge of the functional zone of the terminal (Figure 1a), as this is the area of the part that will be requested when forces are imposed. The knowledge of the functional zones allows the designer to control the injection process on these areas and, if necessary, to work on their optimization on the mould. In order to allow the best performances possible, one cannot forget that the moulds that are used to produce those parts are constantly exposed to highly severe conditions, such as high pressure, rapid temperature fluctuations and erosion from fast-moving molten metal [18], so a good comprehension of the flow process in the injection system is needed.

The foundry processes bring a set of defects which can be originated in different phases, from design to production, and may be closely linked to a poor evaluation during the design phase, the bad definition of machine parameters, or negligence during production. A molten part can, therefore, present a varied range of imperfections originated on different causes [19]. In the injected casting, one of the most common defects is porosity, which is usually classified in die casting as gaseous porosity, rejects, or flow porosity, all of which are intrinsically related to process problems [20].

The objective of this study is to deepen the work previously carried out in this field [21], improving the knowledge about the factors that induce problems in the injection of small terminals in control cables of motor vehicles. The aim is to eliminate or significantly reduce the presence of pores and other defects in the injected terminals by using techniques such as Computational Fluid Dynamics and analytical calculations with a view to finding a methodology that allows predicting the appearance of defects and allows that these same defects do not occur.

2. Methods

2.1. Definition of terminal geometry

The dimensions of the terminals vary depending on the diameter of the metal cable and the stresses of the forces applied and must obey to a minimum thickness between the most peripheral point of the cable and the wall of the terminal, in order to avoid breakage upon stress. It is also paramount for the resistance of the assembly, the knowledge of the functional zone of the terminal (Figure 1a), as this is the part zone that will be requested when forces are imposed. In the case of injected terminals, the knowledge of functional zones allows the designer to control the injection process of these zones and, if necessary, to work on their optimization, in order to allow the best performances possible. The terminal analysed in this study was designed in a special configuration (Figure 1b), resembling a crank. It is characterized by having a thick solid area in its central zone, from where at its top extends an engaging arm, making all these components part of its functional zone. A description of the terminal's properties can be found in Table 1.

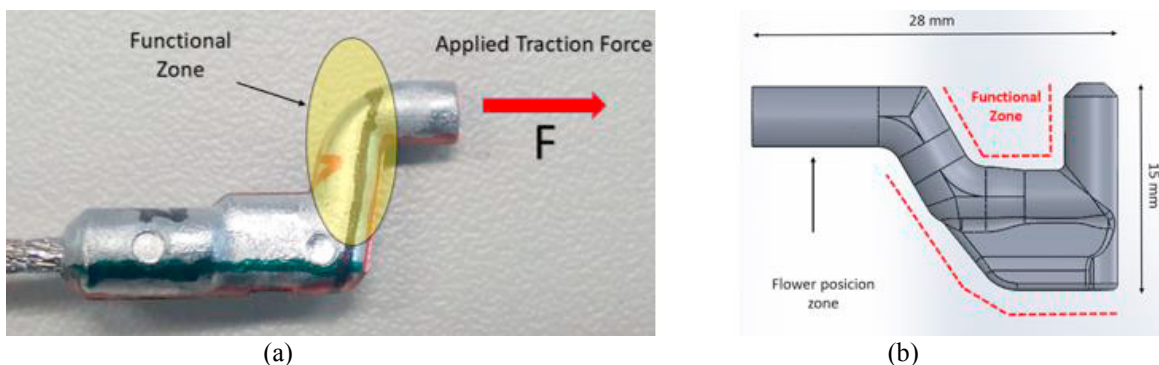

Fig. 1. (a) Description of the functional zone of this terminals design; (b) Description of the terminal under study

Table 1. Important characteristics of the terminal for the injection process

Part characteristics	Values	Units
Dimensions		
length	28	mm
width	15	mm
maximum thickness	5	mm
Part volume	733.5	mm ³
Injection time	0.35	s

2.2. Definition of the moulds

The mould (Figure 2) is one of the most important components of the whole process, because it is in it where the molten metal takes shape, and the projected part is produced. Moulds are thus structures with dimensions varying from small plates with printed gypsum, to complex mechanisms with movable elements inside, to allow feeding, cooling, and extraction of the castings. The case in study refers to the injection of cable lugs, where the mould consists of two steel plates (upper and lower), called moulding inserts, which share the impressed moulding cavity between them. Also, the lower plate includes the planting system. These plates are in turn mounted in an assembly which accompanies the moulds, called docking structures, and which have several purposes besides fixing the mould plates. In order to optimize the operating cycle, these structures also provide a connection between the mould plates and the injection nozzle and support the mould cooling, and extraction systems.

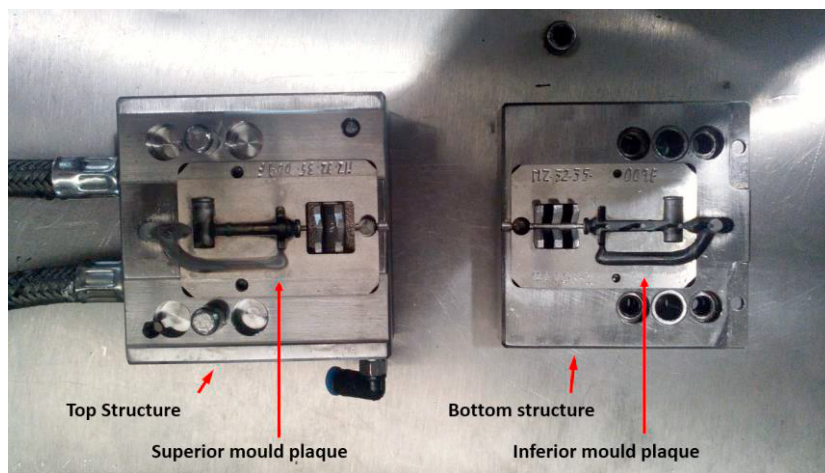

Fig. 2. Description of the mould structures with the mould inserts docked

2.3. Mould Inserts.

The mould inserts (Fig. 3a and 3b) or moulding system, are plates produced in accordance with the North American Die Casting Association (NADCA) standard in AISI H13 high chromium and molybdenum tool steel. In each insert, a cavity is printed corresponding to half the figure of the part to be obtained. In the lower plate, the gyration system is also printed, with dimensions that vary according to the number of sprues, and their locations depending on the design. These plates are fixed to the corresponding structures, initiating the operation cycle after the closure of both, and the injection of the molten metal into the cavity. The thickness of each plate varies in order of the height of each part, with a minimum of 8 mm thickness for at least 12 mm in height.

The mould used in this study with the reference 12232249 (Fig. 1b), follows the arrangement line of the components described and is characterized by having a double gating system, composed of two channels and two sprues (Fig. 3a and 3b). Dimensionally, it complies with the values described in Table 2.

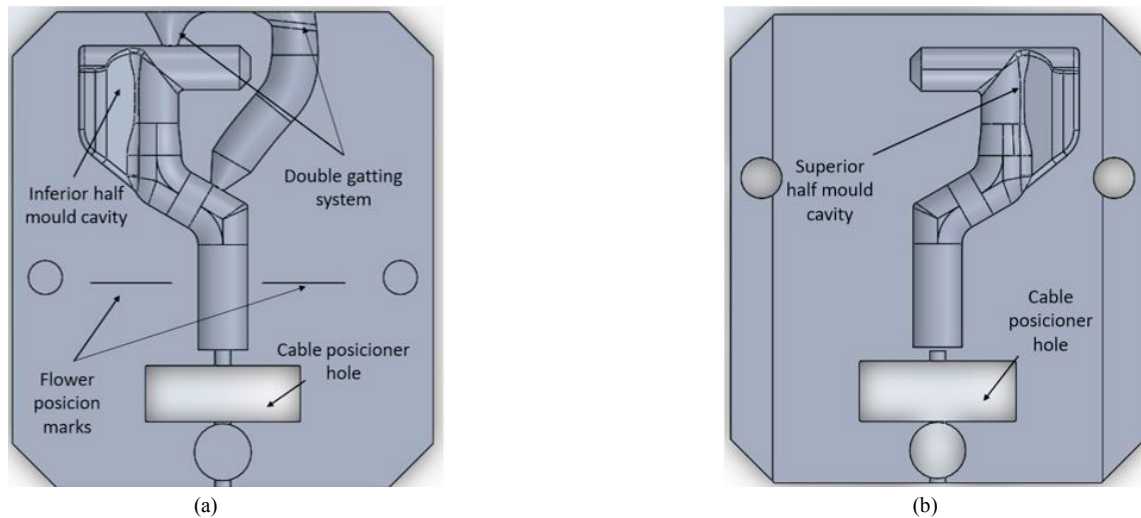

Fig. 3. Description of the mould insert and its systems: (a) lower cavity and (b) upper cavity

Table 2. Mould characteristics

Characteristics	Values	Units
Dimensions		
length	43	mm
width	28	mm
plates thickness	8	mm
Cavities volume		
Produced part	733.5	mm ³
Gating system	278.5	mm ³
Total	1012.0	mm ³

2.4. Description of the problem

For the die casting process to be effective, one must have the knowledge of the existing phenomena and applicable machine parameters. The absence of such knowledge might bring huge problems to the quality of the parts produced. In this context, the problems start to appear, resulting in a high number of rejected parts produced. The parts obtained by casting showed changes observed in the gloss level, presenting a spleen, being an indication of possible problems in the cooling system. At the same time, during the tensile tests carried out for the terminals quality control, it was observed that they broke through their functional zones (Fig. 1b), without reaching the minimum load established to be considered as a good quality part. The assignment of the problem to the characteristics of the molten material was considered remote, although not totally set aside, due to the fact that only three of the terminals types produced in the factory were faulty. Hence, the possibility of being a process problem was considered, thus giving start to a problem analysis process. A detailed study of the terminal regarding the identified problems and indicated failures in the production process was performed, namely during the injection and extraction cycles of the parts. A detailed analysis to the structure of the tested specimens revealed that they had porosities and rejects, supposedly induced by a failure in the feeding process, in terms of velocities and flow regimes, together with a poor layout of the feeding systems. A significant cause in these defects, in particular at the level of rejects, is the cooling of the mould, since a part must be cooled under ideal conditions. Failure of this time

window implies a slow diffusion of heat, and a longer stage of the part at a certain temperature, or, on the contrary, an instantaneous cooling. Whatever the scenario, these situations should always be avoided. The data collected was translated into an Ishikawa's diagram, which defined the factors and causes to be studied in depth, and directs the analysis to the mould and its structures, more concretely in the following items: a) flow regime in the mould, b) injection metal velocity and pressure, c) design of injection moulding systems, d) air vents from mould cavities and e) cooling process of mould and injected parts.

2.5. Framework

The study was divided into various stages. The first stage started with the analysis of a cut cross-section of the part, in order to determinate the defects presented in the section, as well as their quantity. In a second stage, flow simulations were made, to analyse the air fraction, turbulence and velocities presented during the filling. To allow these simulations to be made, it was also necessary to calculate the pressures and velocities at the entrance of the gating system, in order to find the value of this last parameter to be applied in the software, and the Reynolds number to obtain the flow regime, regarding that a good injection regime must be a laminar one. Then, the study moved forward to mould improvement implementations, according to the results achieved. Once again, the simulations were repeated and the new cross-sections were analysed. New calculations of pressures, velocities and Reynolds number were performed for the newly implemented improvements in an empirical iterative process.

2.6. Cross-section surface analyses of the tested parts

The preparation of the test pieces for analysis was carried out after cuts have been made according to the figure 4a. The parts were then sanded using sandpaper grades of 500 and 1000 mesh, and at the end, polishing process was performed using a suspension with diamond powder of 3 μm , resulting in surfaces like the one shown in Fig. 4b. The parts were then analysed using a magnifying glass with a magnification of x25, in order to quantify the defects, according to the Broose 590589-100: 2012 standard [22], which implies the use of a digital program to quantify the defects presented. In this case, the program Image J[®] was used (Fig. 4c).

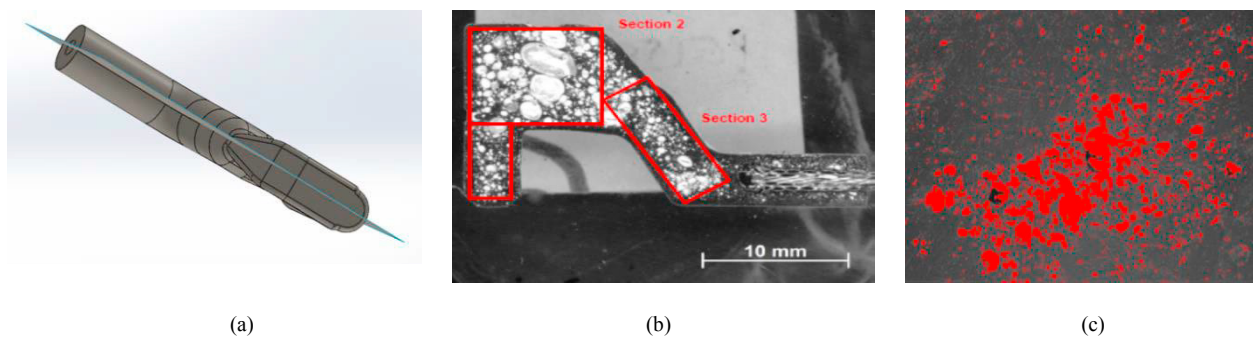

Fig. 4. (a) Plane cut of the terminal for surface analyse; (b) Cut sections selected of the terminal surface; (c) Example of a surface analyse using the Image J software

2.7. Description of the simulations

To understand the flow process inside the moulds, CFD (Computer Flow Dynamics) simulations were used. The analyses were made using FLOWCast[®] simulation software, and the study focused on the following: the volumetric fraction of air, turbulence and injection speed. The parameters applied in the software can be found in Table 3.

Table 3. Parameters used in the simulation software

Parameters	Values	Units
Global		
Cells width	0.0003	m
Metal		
Metal temperature	430	°C
Reference temperature	387	°C
Heat transfer coefficient (Zamak 5)	110	W/m/K
Mould		
Initial mould temperature	95	°C
Heat transfer coefficient (AISI H13)	28.6	W/m/K
Reference		
Number of cells	46332	[]
Metal pressure	10777.3	kPa
Metal velocity	1.41	m/s
Temperature	387	°C
Filling time	0.35	s

3. Results

3.1 Venting system

To address the problem of the remaining gases still trapped in the metallic liquid, it was decided to create gas escape channels in the mould. The section calculation of these channels follows a model that takes into account the characteristics of the terminal under study. The depth of the channels varies depending on the type of metal to be injected. In the case of zinc alloys, this height should not exceed 0.1016 mm [23]. Based on these values, the section should have a rectangular profile (Fig. 5a), varying only its width. Fig. 5b shows the width and the cross-section area of the escape (L and S, respectively).

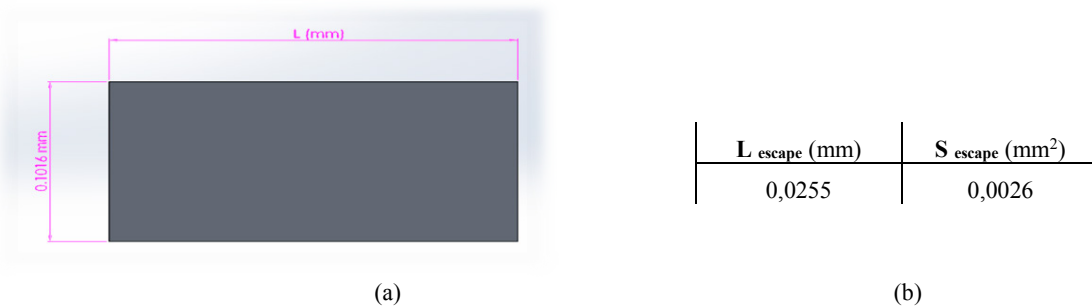

Fig. 5. a) Dimensions of the air venting section; b) width and volume calculated for the section

3.2 Gating system

Analysing the simulation flow regimes of mould filling, and according to the conclusions achieved in the previous work [21], the gating system was improved by modifying the number of sprues, and their geometry. The first amendment was drawn up in order to avoid turbulent regimes by flow collision, thus decreasing its entropy. Thus, the cavity will be fed by only one sprue instead of the initial two. The second amendment taking into account was the outlet geometry of the sprue. For this, a MATLAB[®] application was developed, which returns the geometry of the gating output by determining the ideal Reynolds number for a certain flow rate and speed. The application checks for restrictions on the maximum thickness that the outlet should present, due to the ability of the sprue

cutting mechanism. Regarding this, the thickness should never exceed 1,3 mm. Also, with regard to the configuration, a geometry composed of a central rectangle variable in width and height and provided with fixed areas was developed, in order to smooth the flow (Fig. 6). With this construction, a variable geometry can be obtained in function of the desired flow, varying also the sprue according to the figure to be injected.

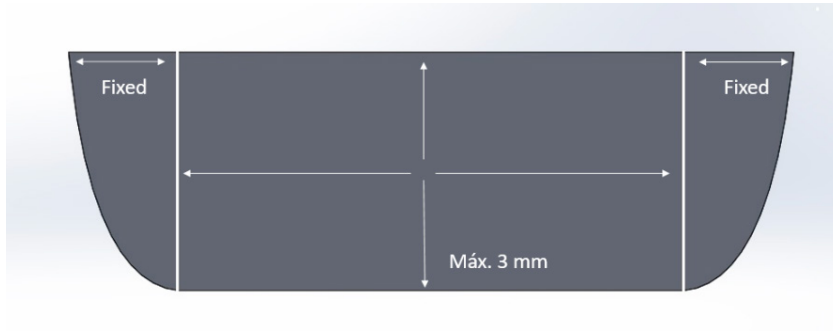

Fig. 6. Section of the sprue with fixed and movable areas

3.3 Mould improvement

Taking into account the data obtained by simulations, it was decided to develop a controlled mould with the improvements implemented. In this particular case, the dimensions of the sprues and ventilation system were increased, taking into account the minimum values obtained, and their location was defined. In Table 4, one can check the variation of these values and, in Fig. 7 one can observe the new mould design.

Table 4. Dimensions of the sprues sections before and after improvements applied

Dimensions	Before Improvement	After Improvement
Area (mm ²)	4.3	5.5
Perimeter (mm)	9.09	16.99
A (mm)	3.5	8.0
B (mm)	1.3	0.7
C (mm)	2.74	7.0

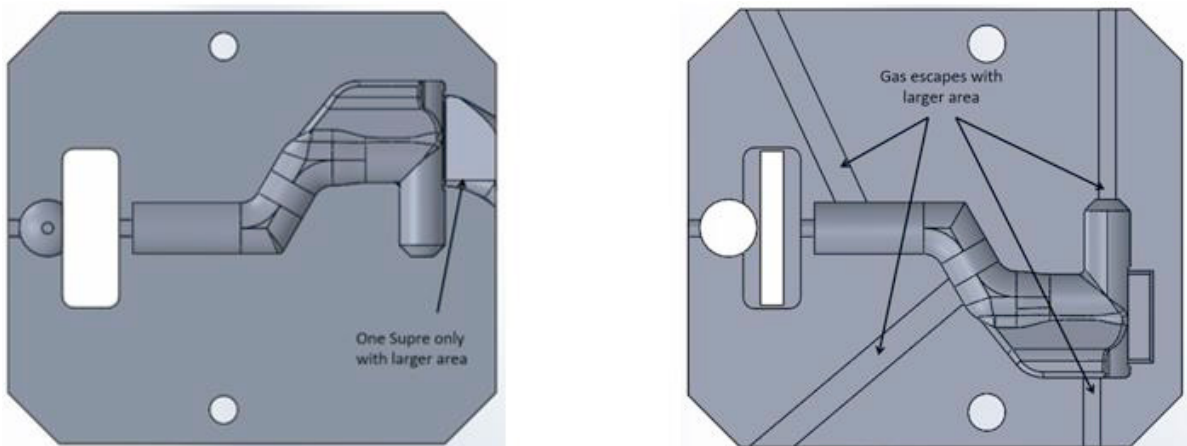

Fig. 7. Description of the mould inserts optimized

4. Discussion

The results obtained before and after the implementations made were checked. In Table 5, one can check the simulations made for both moulds, while in Table 6 the simulation results obtained by applying the procedures described in 2.7 are shown.

Table 5. Dimensions of the sprues sections before and after improvements applied

	μ (kg/m ³)	Q (m ³ /s)	U (m/s)	D _h (m)	μ (kg/m·s)	R _e
Before Improvement	6600	2,9 E-6	1,141	0,0018	0,003737	3627.26
After Improvement	6600	2,9 E-6	0,52728	1,2949	0,003737	1205828

Table 6. Comparison of the simulations made for 1) air fraction; 2) turbulence; 3) velocity; before at left and after improvements at the right

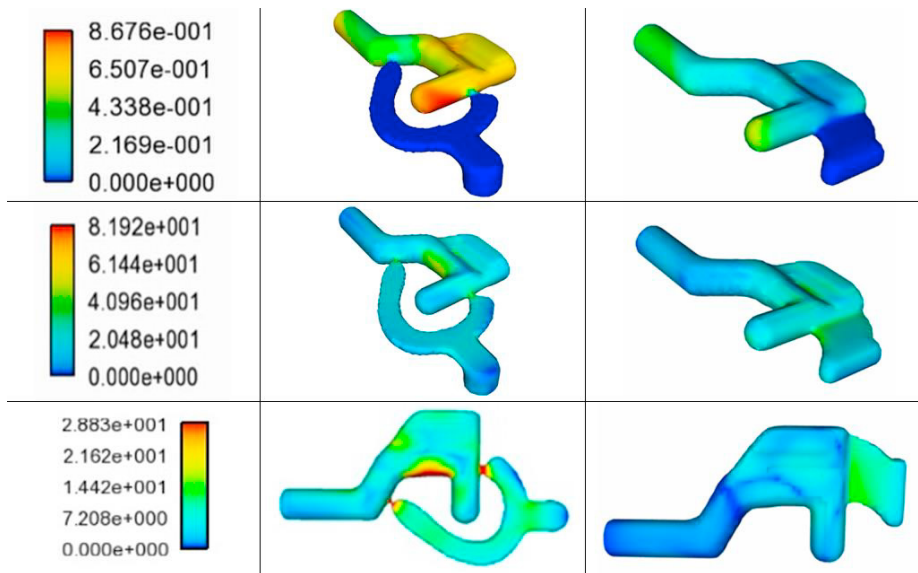

As far as the flows are concerned, there is a significant and general improvement in all aspects, as indicated in Table 6. Both the percentage of air retained in the moulding, as well as the turbulence and velocity decreased significantly, not only at the maximum value reached but also throughout the entire filling process, which supports the theory that the porosity index is interconnected with the flow characteristic. The reason for a drop in turbulence values has to do with the percentage of the injected metal mass since the feed is performed with a higher flow rate, which fills the part more evenly and without the high friction chains creation, which promotes that phenomenon. The decrease in turbulence is also aided by the decrease in velocity, which contributes to a smaller Reynolds number, due to flow closer to the laminar.

Comparing the obtained results, both the final values of the filling and the indexes of porosities, it is observed that a significant improvement was obtained with respect to the volume fraction and turbulence. Improvement is supported by the indexes of porosity obtained in the micrographic analyses and exposed in Table 7, which indicate a decrease of this index in all the tested parts, thus ensuring the validation of the studies.

Table 7. Comparison of the porosities results of the cut surface analyses

Sections	Porosities (%)					
	Specimen 1		Specimen 2		Specimen 3	
	Before	After	Before	After	Before	After
Section 1	31.7	8.5	11.3	3.3	7.7	4.0
Section 2	62.8	1.7	8.0	2.8	17.0	2.3
Section 3	41.2	4.8	6.3	5.4	11.7	5.8

In the present study, gas exhaustion and reduction of turbulence during the filling process were of vital importance as it effectively reduced the volume of gases trapped inside the casting. These results are in line with that reported by Ferreira [24], who used risers with access to the outside of the mould to allow gas exhaust. On the other hand, Kwon and Kwon [25] showed that the porosity index is also affected by the gates and runners geometry. Also, Sun *et al.* [26] studied the problem of turbulence and porosity generation in injected castings, noting that there are areas where the velocity in the gating system suddenly increases, leading to turbulence generation. Teixeira [27] also pointed out that turbulence generates retention of gases inside the castings, and that this is due to excessive injection speed, which causes turbulence in the runners. On the other hand, Tian *et al.* [28] state that the main cause for the generation of porosity in castings is the existence of inclusions in the molten metal. Also, Silva *et al.* [15] observed that the existence of properly positioned gas exhaust sites gives rise to better surface finish and lower defect rates.

5. Conclusions

Regarding the study, it can be concluded that the values obtained in the simulations have been validated and the porosity results analysed. It is important to note the importance of using gas exhausts and the reduction of the turbulence regime at the time of injection, which contributed to a reduction on the formation of gas pockets and, consequently, to decrease the porosity index. The reduction of the regime turbulence, however, can be performed in several ways, the simplest being the reduction of the injection pressure, and the most complex, the alteration of the flow and gating channels. In this case, the second hypothesis needed to be chosen, since reducing pressure would lead to a loss of productivity, which should be avoided. This option leads us, in the end, to conclude the importance of applying only one sprue instead of several, along with a wide injection area, so as to relieve pressures and make the flux flow. In the end, it can be concluded that this work has achieved the desired objectives, deepening knowledge about the phenomena of flow in the casting process.

References

- [1] C. Rosa, F. J. G. Silva, L. P. Ferreira, T. Pereira, R. M. Gouveia, Establishing standard methodologies to improve the production rate of assembly-lines used for low added-value products, *Procedia Manufacturing* 17 (2018) 555-562.
- [2] Brian Cantor, P. Grant, C. Johnston, *Automotive Engineering Lightweight, Functional, and Novel Materials*, CRC Press. Philadelphia, U.S.A. 2008. ISBN: 9780750310017.
- [3] Khuram Shazhad. Cloud robotics and autonomous vehicles. *Autonomous vehicles*. A. Zak (Editor). InTechOpen, 2016, pp. 0-19. <http://dx.doi.org/10.5772/64064>.
- [4] D. Mann, *Automotive Plastics and Composites* (2nd ed.). Elsevier Science Ltd. Amsterdam, 1999. ISBN: 9780080527741.
- [5] J. Heizer, C. Munson, B. Render, *Operations Management, Sustainability and Supply Chain Management* (12th ed.). Pearson. London, 2017. ISBN: 978-0134163512.
- [6] H. Santos, M. T. Pereira, F. J. G. Silva, L. P. Ferreira. A Novel Rework Costing Methodology Applied to a Bus Manufacturing Company, *Procedia Manufacturing* 17 (2018) 631-639.
- [7] O. J. Bratz. Push-Pull Cable, United States Patent Office. Patent US3015969A, 1958.
- [8] C. Rosa, F. J. G. Silva, L. P. Ferreira, R. Campilho, SMED methodology: the reduction of setup times for Steel Wire-Rope assembly lines in the automotive industry, *Procedia Manufacturing* 13 (2017) 1034–1042.
- [9] B. M. D. N. Moreira, R. M. Gouveia, F. J. G. Silva, R. D. S. G. Campilho, A Novel Concept Of Production And Assembly Processes Integration, *Procedia Manufacturing* 11 (2017) 1385–1395.
- [10] M. A. Boles, Y. A. Çengel, *Thermodynamics an engineering approach* (5th ed.), McGraw-Hill, Inc., New York, 2014. ISBN: 9780070606593.
- [11] S. Memmola, Bowden Cable, United States Patent Office. Patent US4683774A, 1987
- [12] C. Rosa, F. J. G. Silva, L. P. Ferreira, Improving the quality and productivity of steel wire-rope assembly lines for the automotive industry, *Procedia Manufacturing* 11 (2017) 1035–1042.
- [13] E. M. G. F. Braga. Otimização do processo de injeção de Zamak (in Portuguese). MSc Dissertation, Master's in Mechanical Engineering, ISEP – School of Engineering, Polytechnic of Porto, Porto, Portugal, 2015.
- [14] CMA, *Control Cables Design Guide*, CMA – Cable Manufacturing and Assembly Co, Bolivar, OH, U.S.A. [Online] Available on: <https://www.cmacable.com/mechanical-cable/m-guides/control/>. Accessed on 15th of February, 2019.
- [15] F.J.G. Silva, R. D.S.G. Campilho, L. P. Ferreira, M. T. Pereira, Establishing Guidelines to Improve the High-Pressure Die Casting Process

- of Complex Aesthetics Parts, *Advances in Transdisciplinary Engineering, Transdisciplinary Engineering Methods for Social Innovation of Industry 4.0*, M. Peruzzini et al. (Eds.), 7 (2018) 887-896. DOI: 10.3233/978-1-61499-898-3-887.
- [16] D. C. C. Ferreira, *Mitigação das causas geradoras de defeitos em peças metálicas injetadas de caráter estético* (in Portuguese), MSc Dissertation, Master's in Mechanical Engineering, ISEP – School of Engineering, Polytechnic of Porto, Porto, Portugal, 2017.
- [17] *Ficocables, Zamak Technical Handbook* (in Portuguese), Ficocables, Maia, Portugal. 2004.
- [18] V. Nunes, F. J. G. Silva, M. F. Andrade, R. Alexandre, A. P. M. Baptista. Increasing the lifespan of high-pressure die cast molds subjected to severe wear. *Surface and Coatings Technology*, 332 (2017) 319-331.
- [19] M. T. Rowley, *International atlas of casting defects*, American Foundry Association, ASM International, Novolty, OH, U.S.A. 2008. ISBN: ISBN: 978-0874330533.
- [20] C. Tian, J. Law, J. van der Touw, M. Murray, J. Yao, D. Graham, D. S. John, Effect of melt cleanliness on the formation of porosity defects in automotive aluminium high pressure die castings, *Journal of Materials Processing Technology* 122 (2002) 82–93.
- [21] Helder Pinto, F. J. G. Silva. Optimization of die casting process in Zamak alloys. *Procedia Manufacturing* 11 (2017) 517–525.
- [22] Brose 590589-100 Standard, 2012.
- [23] W. Andresen, *Die Casting Engineering: A Hydraulic, Thermal, and Mechanical Process*. CRC Press, Boca Raton, FL, U.S.A., 2004. ISBN: 9780824759353.
- [24] J. P. S. Ferreira, *Simulação numérica e validação experimental de sistemas de enchimento em fundição* (in Portuguese), MSc. Dissertation, Mechanical Engineering Department, School of Engineering, University of Minho, 2014.
- [25] H.-J. Kwon, H.-K. Kwon, Computer aided engineering (CAE) simulation for the design optimization of gate system on high pressure die casting (HPDC) process, *Robotics and Computer Integrated Manufacturing* 55(B) (2019) 147-153.
- [26] J. Sun, Q. Le, L. Fu, J. Bai, J. Tretter, K. Herbold, H. Huo, Gas entrainment behavior of aluminum alloy engine crankcases during the low-pressure-die-casting process, *Journal of Materials Processing Technology* 266 (2019) 274-282.
- [27] R. M. M. Teixeira, *Estudo numérico do efeito dos principais parâmetros de fundição na formação de rechupes em peças fundidas* (in Portuguese), MSc dissertation, Department of Industrial Engineering, Polytechnic of Bragança, 2013.
- [28] C. Tian, J. Law, J. der Touw, M. Murray, J.-Y Yao, D. Graham, D. St. John, Effect of melt cleanliness on the formation of porosity defects in automotive aluminium high pressure die castings, *Journal of Materials Processing Technology* 122(1) (2002) 82-93.