

Industrie 4.0
Framework, Challenges and Perspectives

by
Miguel Alexandre da Silva Correia

Thesis
for attainment of the academic degree of

Master of Engineering
(M. Eng.)

Presented to the Faculty of Engineering
Hochschule **RheinMain**, University of Applied Science



Hochschule **RheinMain**
University of Applied Sciences
Wiesbaden Rüsselsheim

Rüsselsheim

2014

Thesis Advisors: Prof. Dr. Matthias Halbleib
Prof. Dr.-Ing. Karlheinz Sossenheimer

Second Advisor: Dr. Ing. João Bastos

I affirm that I have written the dissertation myself and have not used any sources and aids other than those indicated.

Date / Signature: _____



Faculty of Engineering

Department of Mechanical Engineering

2014

Master's thesis in the degree program for
Miguel Alexandre da Silva Correia

Industrie 4.0

Framework, Challenges and Perspectives

Problem description:

Local economies can no longer be protected by their cultural isolated condition in a global and technological world. After researching several documents available about the subject *Industrie 4.0* in a global view, the opinion and vision of the various participants in direct targeted strategy that could exist on the theme in the German national reality, it's difficult to find any common operational model to be implemented. Only recommendations.

As yet the theme of the object of study is in an initial phase, is an opportunity for exploring new and emerging ideas for reflection and insights, approach, role and potentialities. Understanding how the interaction between the several players in collaborative industrial projects performed occurred along the entire value chain including customer, operator, supplier allow conducting a reflection about interactive business relations and industrial reorganization needed in the German industries reality for the future.

Objectives:

- Research and strategic dissertation of the framework, challenges and perspectives of the *Industry 4.0*.
- Literature study, screening of research documents on the field, evaluation of the concept, summary and outlook of steps to come.

Abstract

The world is increasingly in a global community. The rapid technological development of communication and information technologies allows the transmission of knowledge in real-time. In this context, it is imperative that the most developed countries are able to develop their own strategies to stimulate the industrial sector to keep up-to-date and being competitive in a dynamic and volatile global market so as to maintain its competitive capacities and by consequence, permits the maintenance of a pacific social state to meet the human and social needs of the nation. The path traced of competitiveness through technological differentiation in industrialization allows a wider and innovative field of research. Already we are facing a new phase of organization and industrial technology that begins to change the way we relate with the industry, society and the human interaction in the world of work in current standards.

This Thesis, develop an analysis of Industrie 4.0 Framework, Challenges and Perspectives. Also, an analysis of German reality in facing to approach the future challenge in this theme, the competition expected to win in future global markets, points of domestic concerns felt in its industrial fabric household face this challenge and proposes recommendations for a more effective implementation of its own strategy.

The methods of research consisted of a comprehensive review and strategically analysis of existing global literature on the topic, either directly or indirectly, in parallel with the analysis of questionnaires and data analysis performed by entities representing the industry at national and world global placement.

The results found by this multilevel analysis, allowed concluding that this is a theme that is only in the beginning for construction the platform to engage the future Internet of Things in the industrial environment Industrie 4.0.

This dissertation allows stimulate the need of achievements of more strategically and operational approach within the society itself as a whole to clarify the existing weaknesses in this area, so that the National Strategy can be implemented with effective approaches and planned actions for a direct training plan in a more efficiently path in education for the theme.

Keywords: *Industrie 4.0, Cyber-Physical-Systems, Internet of Things, Smart Factories.*

Acknowledgements

I would like to gratefully acknowledge the support of my advisors, Prof. Dr. Matthias Halbleib, and Prof. Dr. Eng. Karlheinz Sossenheimer, during my Master Thesis Dissertation, whom encouraged me to pursue this research topic as my dissertation and pushed me to follow many opportunities that have helped me developing my intellect and learning skills. I appreciate all contributions of time, ideas to make this document experience productive and stimulating.

I would like to gratefully acknowledge the support of my second advisor, Dr. Ing. João Bastos, for the support and believing in me, was giving the freedom with which I have always been guided for the choice of my academic challenges.

I would also like to thank Frau Silke Schuster, who provided me the opportunity to come to Hochschule Rhein Main in this enrollment program and all the support given in my stay here.

I am grateful for my parents, whom has made it possible for me to pursue my education for them constant encouragement, reassurance, patience, and efforts to make me feel good in walking this way.

*“The world as we have created it is a process of our thinking.
It cannot be changed without changing our thinking.”*

Albert Einstein

Contents

Abstract	ii
Acknowledgements	iii
Contents	v
Abbreviations and symbols	vii
List of Figures	ix
List of Tables	x
1. Introduction	1
1.1. Contextualization	1
1.2. Objective	1
1.3. Organization of the report	1
2. Industry 4.0	2
2.1. Historical review	2
2.2. The global competition	5
2.3. The potential of <i>Industrie 4.0</i>	7
2.4. Germany and the new industrial Era	8
2.4.1 Germany National Strategy	10
2.4.2 The fundamental new approach	11
3. Internet of Things	14
3.1. Pre-requisites	17
3.2. Reference model and architecture	20
3.3. Cloud Computing.....	24
3.4. Internet of Things in Industrial Production	26
4. Cyber Physical Systems	27
4.1. Pre-requisites	29
4.2. Reference model and architecture	29
4.3. Difficulties to overcome.....	31
5. The challenges	34
5.1. Challenges for engineering	34
5.2. Challenges in industrial environment	37
5.3. Challenges in industrial Security	38

5.4. Challenges in the new decentralized production philosophy.....	39
6. The benefits from different perspectives	40
6.1. Productivity and Internet of Things	41
6.2. Business Opportunities	45
6.3. Jobs creation	47
6.4. Risks and approaches to manage them	48
7. Applications of the concept	52
7.1. Advanced Manufacturing.....	52
7.2. Smart Plants	55
7.3. Digital Virtual Plant.....	57
7.4. Smart Manufacturing	60
7.5. Smart Industrial Designs	62
7.6. Smart Manufacturing Enterprise.....	63
7.7. Smart Technologies involved	64
7.8. Smart Education	66
8. Automotive, Mobility and Energy as examples of the new philosophy	67
9. Recommendations to promote the <i>Industrie 4.0</i>	70
10. Conclusions	80
11. Bibliography References	81
12 Glossary	91
Appendix	97
I. Smart Technologies involved in <i>Industrie 4.0</i>	97
II. The SmartFactory ^{KL} Vision Research Case Study	105

Abbreviations and symbols

ACATTECH	German National Academy of Science and Engineering.
ACEA	European Automotive Manufacturers Association.
AM	Additive Manufacturing.
AMT	Advanced Manufacturing Technology.
ARAT	Active Reader Active Tag.
ARPT	Active Reader Passive Tag.
BDI	Federation of German Industries.
BMBF	Federal Ministry of Education and Research.
BMWi	Ministry of Economics and Technology.
BRIC	Brazil, Russia, India, and China.
CAD	Computer-Aided Design.
CAE	Computer-Aided Engineering.
CAM	Computer Aided Manufacturing.
CARG	Compound Annual Growth Rate.
CIM	Computer-Integrated Manufacturing.
CPS	Cyber-Physical System.
CNC	Computer Numerically Control.
DTTL	Deloitte Touche Tohmatsu Limited.
EU	European Union.
EPC	Electronic Product Code.
EPoSS	European Technology Platform on Smart Systems Integration.
ES	Embedded Systems.
FIAO	Fraunhofer Institute for Industrial Engineering.
FMS	Flexible Manufacturing Systems.
Forschungsunion	Industry Science Research Alliance, Germany.
GAO	United States Government Accountability Office.
GDP	Gross Domestic Product.
GPS	Global Position System.
GSMA	Groupe Speciale Mobile Association.
GTAI	Germany Trade & Invest.
GVA	Gross Value Added.

HSM	Hardware Security Module.
IC	Information and Communication.
ICME	Integrated Computational Materials Engineering.
ICT	Information and Communication Technologies.
IMS	Intelligent Manufacturing System.
IoP	Internet of People.
IoT	Internet of Things.
IoS	Internet of Services.
IT	Information Technology.
M2M	Machine to Machine Communication.
MR	Mixed Reality.
NFC	Near Field Communication.
OASIS	Organization for the Advancement of Structured Information Standards.
OECD	Organization for Economic Cooperation and Development.
PLC	Programmable Logic Controller.
PLM	Product Life Management.
PRAT	Passive Reader Active Tag.
R&D	Research and Development.
RFID	Radio Frequency IDentification.
RTOS	Real Time Operation System.
SO	Smart Objects.
SN	Smart Networks.
SS	Smart Services.
SME	Small and Medium-sized Enterprise.
SMLC	Smart Manufacturing Leadership Coalition.
SOA	Service Oriented Architecture.
UC	Ubiquitous Computing.
URL	Uniform Resource Locator.
USN	Ubiquitous Sensor Networks.
WB	The World Bank.
WEF	World Economic Forum.
WTO	World Trade Organization.

List of Figures

Figure 1	Phases of the Industrial Revolution.....	3
Figure 2	Global Production Networks.....	6
Figure 3	Global Industrial Pressures.....	6
Figure 4	Relations between Internet of Things-People-Services.	7
Figure 5	Networking in manufacturing: activating potentials of synergy.	9
Figure 6	Shaping the future of manufacturing.....	11
Figure 7	Innovation Strategy Goals for Germany.....	12
Figure 8	Internet of Things mind map.	14
Figure 9	Internet of Things: the 6 A connectivity's.	15
Figure 10	Internet of Services-Smart-of Things integration.	15
Figure 11	Example of food supply chains in the Era of IoT.	16
Figure 12	Business Model reorganization.	17
Figure 13	Diagram with IoT eco-system that map in to industry sector.	19
Figure 14	Metaphorical representation of the architecture model of reference.	20
Figure 15	Generic reference architecture to <i>Industrie 4.0</i>	21
Figure 16	Smart pallets modeling.	22
Figure 17	Integration of Smart-Virtual-Digital Factories.	23
Figure 18	SOA interactions manage the behavior of the whole CPS of Systems.	24
Figure 19	Cloud based Service Oriented Interaction.	25
Figure 20	Industrial Smart Integration.	26
Figure 21	Evolution of the concept.	28
Figure 22	Integration of Cyber Physical Systems and Internet of Things Philosophies.....	30
Figure 23	Levels of industrial security.	38
Figure 24	End to End solutions in all fields.	41
Figure 25	Growth of the M2M communications.	42
Figure 26	The evolution of the interaction between the elements.....	43
Figure 27	Increase of productivity to the most varied levels.....	44
Figure 28	Manufacturing scenario involving different stakeholders in future enterprise.....	45
Figure 29	Business systems towards usage of Networked Devices Enabled Intelligence....	46
Figure 30	Value networks in business innovation.	46
Figure 31	Employment Multiplier Effect.....	47

Figure 32	Energy management and risks mitigation.	51
Figure 33	Dynamic relations with Advanced Manufacturing Engineering.	52
Figure 34	Schematic of alteration of production capacity.	53
Figure 35	Framework conditions for integration of the process.	54
Figure 36	Advanced manufacturing enterprise concepts.....	54
Figure 37	Smart Factory connectivity in <i>Industrie 4.0</i>	55
Figure 38	Smart Factory global view.	56
Figure 39	A conceptual framework of Integrated Factory Design.	58
Figure 40	Cyber Physical Production System.	59
Figure 41	Digital software to assist and support the decision makers.	59
Figure 42	Integrated Smart Manufacturing.	60
Figure 43	Smart Manufacturing: the 3 I's.	61
Figure 44	Smart Manufacturing flexible production.	61
Figure 45	3 D Printing and integrating forms.	62
Figure 46	Software to support Smart Industrial Design.	62
Figure 47	Smart Manufacturing Enterprise relations approach.	63
Figure 48	Communication Technologies.....	64
Figure 49	M2M Communication integration.	65
Figure 50	The extended concept of the Teaching Factory Paradigm	66
Figure 51	Smart Manufacturing Enterprise traceability.	67
Figure 52	Cyber Physical Systems integrating society	70
Figure 53	Communication integrating society	75
Figure 54	Integration of the Internet of Everything	79
Figure 55	Technologies integration	97
Figure 56	NFC Communication Modes	99
Figure 57	RFID Communication system	100
Figure 58	Bluetooth device configuration	101
Figure 59	Wireless Network Technology	102
Figure 60	WiMAX & Wireless Infrastructure Equipment Block Diagram	104
Figure 61	SmartFactoryKL Vision Research Case Study Living Lab	105
Figure 62	SmartFactoryKL Vision Research technology integration	106
Figure 63	SmartFactoryKL Vision Research maintenance service	108

1. Introduction

1.1. Contextualization

2013 marks the turning point on the focus of attention on the theme *Industrie 4.0*.

Industrie 4.0, is a term with reference to the 4th Industrial Revolution shaped by German Government and industry leaders, researchers, associations, and unions, for describing a joint National Strategy to improve the industry describing the fundamental paradigm shift from a centralized production to a decentralized production and control (BMW, 2013).

A quick global search reveals the lack of information to understand all the implications and repercussions that this matter will awake in German industrial society. In this context, the author of this research has accepted the challenge to research on this topic in order to provide not only a comprehensive understanding but, also recommendations to help and contribute to all the interested parties, understand and approach to the concept.

1.2. Objective

The aim of this Thesis is to allow an understanding of the framework, challenges and perspectives of the *Industrie 4.0* theme, in a global industrial perspective.

1.3. Organization of the report

This report is organized as follows: in Chapter 2, is considered a historical review of the Industrial Revolution, presented the need that motivated the development of Germany National Strategy, and its considerations. In chapter 3, is presented the concept of Internet of Things, with their constructive characteristics and technological interactions that allow the new industrial philosophy. In chapter 4, is presented the digital and physical media that will be involved in industrial reorganization in all value-added chain. In chapter 5, are listed some of the most important challenges that the entire community will have to overcome to implement this new philosophy. In chapter 6, are stimulated some of the benefits generated with this new industrial philosophy through different perspectives of the stakeholders. In chapter 7, are some applications of the concept to a practical understanding in the industry level. In chapter 8, is carried out some example fields like automotive, energy and mobility as examples of the new philosophy. In chapter 9, are presented some alerts, warnings and concerns in the form of recommendations. In chapter 10, the conclusions obtained along the realization of this Thesis on the theme *Industrie 4.0* and its current momentum.

2. Industrie 4.0

The industry is beginning to absorb the integrated relations allowed by the Internet of Things and Services. This obligate the entire industrial organization prepares itself for a change of its concept of business model. The integration of networks for sharing data and knowledge through a direct integration at its productive system, allow a new creation of added value and benefits in a comprehensive manner for all the interested parties. This allowed reacting to changing global markets increasingly uncertain.

2.1. Historical review

The basis of the economy in Europe, as well as its style of life, is based in the industrial revolution (Flegel's, 2009). This also has led to an economic growth at the pair of some social and environmental disasters in some nations (Jovane, 2009). The technological development allowed over the time a globalization of industrial technologies. The consequence was economical and social development of many countries shaping the current world market.

The term Industrial Revolution, has caused a lively discussion about its genesis and applicability over the recent times in the scientific community (Coleman, 1983). However, it has been widely accepted as a representative element of differentiated phases as a development of productive technological capacity through creativity as a key factor for the growth, development and change of the condition of human society and the environment. It can be argued that the Industrial Revolution has become a set of macro inventions that allowed an acceleration of micro inventions. This created events that changed irreversibly the face of society in a global sense even in some cases, no scientific basis supporting a pragmatic knowledge about how things worked (Mokyr, 1985).

The First Industrial Revolution emerges with the junction between the mechanical capabilities allowed by kinetic energy with the thermal energy at the end of the 18th Century. Up to this time, it seemed impossible the idea that one could lead to another in order to increase the productivity (Cipolla, 1965). The first mechanical looms created by Henry Cort in 1784, emerged the starting contextualization of the First Industrial Revolution in time frame.

The Second Industrial Revolution is usually dated between 1870 and 1914 (Mokyr, 1998). This was a consequence of fertile period in innovation between 1859 and 1873 (Mowery and Rosenberg, 1989). With profound impact on natural organizational methodology in

production system, the emergence of electrical productive technological systems allowed scale production of goods based on the division of labor. This resulted in an evolutionary continuity of First Revolution (Huges, 1983).

With the ability to use the first Programmable Logic Controller in 1969, it was able to join the synergies between information technologies with electronics. This allowed classifying this industrial reorganization as the Third Industrial Revolution. Also, the increased use of automation in manufacturing processes up to the present day, in a constant spiral of technological innovation, solidifies equipment strategic position in the productive chain.

The Four Industrial Revolution will represent the challenge through the technological integration of Cyber Physical Systems using the Technologies of Information and Communication in industrial processes of manufacturing and logistics. This integration will allow increasing the business value-added chain. Also, it will represent a change in classical organization of industrial work methodologies and development of new business models (acatech, 2013). It's not required only changing the productive systems to manufacture of goods or maintenance of services but, will profoundly changing the working relationship with the human being. The consequences once more will have reflexes in the structure of society and the environment.

Once more, the formal designation of Four Industrial Revolution is not a universal recognized consensus term in a single format accept by all communities.

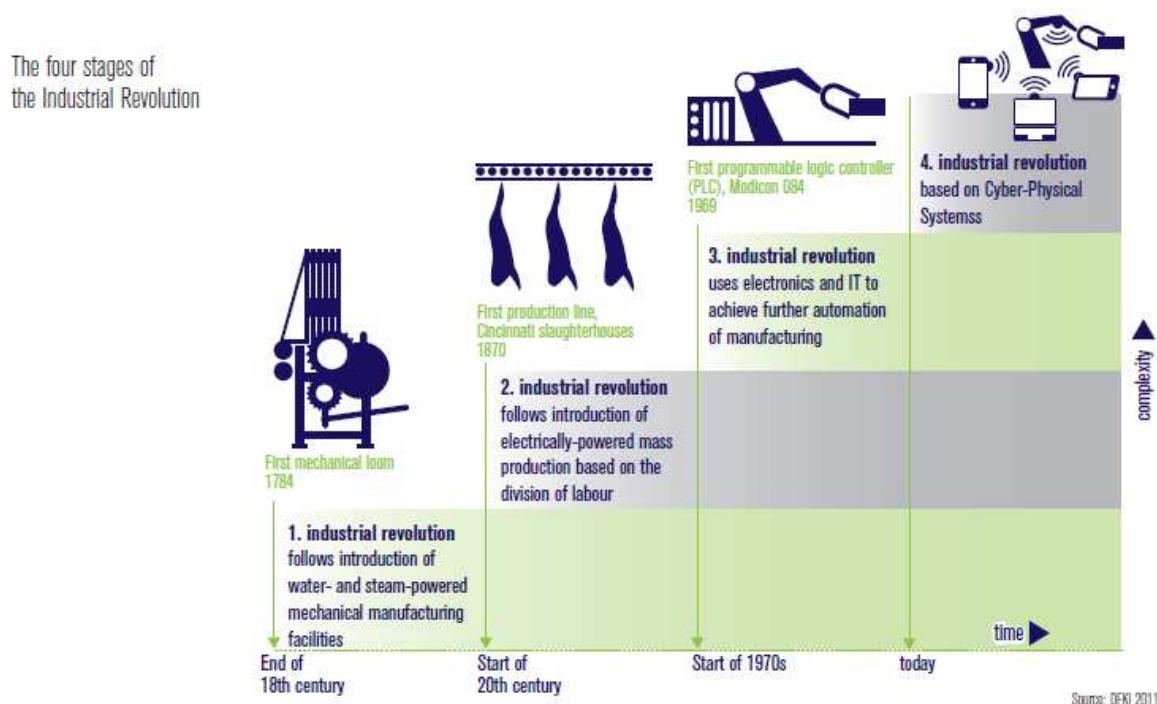

Figure 1. Phases of the Industrial Revolution (source: DFKI, 2011).

For some people in Scientific Community, this term represent the integration of the digital world with the physical designated by Internet of Things. For others it means Third Industrial Revolution especially for those who include the mechanical production of goods in the First Industrial Revolution and do not consider the existence of a Third Industrial Revolution located in the automation of digital manufacturing processes.

Terms such as Smart Production, Smart Manufacturing, Smart Factory, and Advanced Manufacturing among others that may exist are synonyms for the same technological expression used.

The new productive philosophy

Today's competitive pressure in the global market is imposed by the presence of industries in emerging countries. These industrial companies have capacity of technological absorption and presents low operating costs. This is a threat to develop countries such as Germany. It leads to the need to develop and draw up national strategies with joint future visions in society to minimize this external competitive effect with reflexes in the domestic economy. The goal is to boost the national industrial sector in international markets through the creation of economically high value-added elements through innovative products and services. These elements will allow empowering companies and institutions in creation of new markets, differentiating it from other competitors at the same time that minimize their costs by using their resources with more efficiency (Costa, 2009). This way, it is possible to protect and maintain the society in a stabilized environment.

Industry should concentrate its industrial operations through a customization of products and put them in market niches of high profitability. This will have consequences like the need for amendment of the classical productive structure through an increasingly complex introduction of variables and specifications on products and services available. This will require direct investment in the area of innovation to be able for optimizing the productive systems (Westkämper, 2009).

It is expected that the investment on this new productive philosophy will provide a technological innovation capable of providing also an economic boost through intelligent productive systems built for flexible production. Materials and products with highly optimized processes, inserted in supply chains networks will be managed through fast reaction to potential changes in requirements required by client. Products will be tracked throughout its life cycle in service and monitored by a capable and specialized workforce,

allowing a sustainable development (SMLC, 2011). At the same time, will be possible managing resources efficiently in a safety and quality environment for all.

As concerned to those future needs, the German Government in conjunction with all the interested parties, has elaborated and developed a dual common national strategy. This national strategy should create a new dynamism of German Industry so that the industry of manufacture of equipment could be able to keep the ability to position itself in leadership in a global market. Through a consistent integration of Information and Communication Technologies in Cyber-Physical Systems, will provide at the same time, the ability to create and serve new markets for these products. In this context, the word *Industrie 4.0*, represents the description of the fundamental paradigm of transition from a control applied in industry in a centralized manner for a decentralized production. This allow being extremely flexible and individualized, where classic productive barriers disappear creating new technological areas and forms of cooperation that lead to a change of value-added processes and require a reorganization of the division of labor (Bmwi, 2012).

2.2. The Global Competition

The migration and relocation of a portion of the industrial fabric of the most developed technologically nations in the weaker economies, aiming at the reduction of costs of domestic production and trying to increase the level of productivity, allowed the expansion and elevation of competitive industries in the last years on the global level. These companies had an active role in changing the World level competitiveness to claim for itself a part of the implementation of value added in the global marketplace (Hausmann, 2011). This was only possible because the ability and the knowledge acquired through the industrial production of goods were allowed by the transfer of foreign technology from the most industrial countries. As a consequence, were geared the construction and development of internal capacities of knowledge accessible by developing productive processes with the consequent social changes derived from the prosperity created. This prosperity creates and develops a middle class consumer and self sustained due to employment generated. In this context, the economic development in parallel with other key factors, it becomes the engine for a current accelerated globalization since the development of information and communication technologies. These technologies allow streamline the process of industrial technology transfer through allocations and deployment of financial and productive infrastructures. This operational global way is permitted by complexity created around the network of supply chains that allow the satisfaction of the

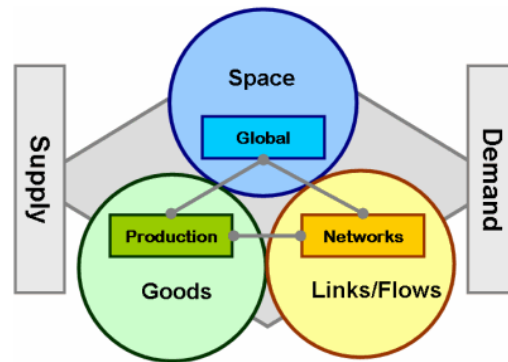

Source: (Hofstra, 2013)

Figure 2. Global Production Networks (source: Hofstra, 2013).

customer needs through a productive capacity units located in universal way in the most various strategic locations of production in the World.

The global competitiveness came compel the most developed countries in reorganize their industrial national strategy to keep themselves in a market increasingly volatile with the rising of emerging competitors that are also claiming a space in it. However, today is still the model of Taylor that guides the organization of the management of production in most industrial organizations. This keeps companies focus on a level of high efficiency for the use of available resources in order to maximize productivity at the same time that introduces a rapid adaptation of productive systems necessary tasks (Bessey et al., 2009).

Manufacturers under tremendous pressure

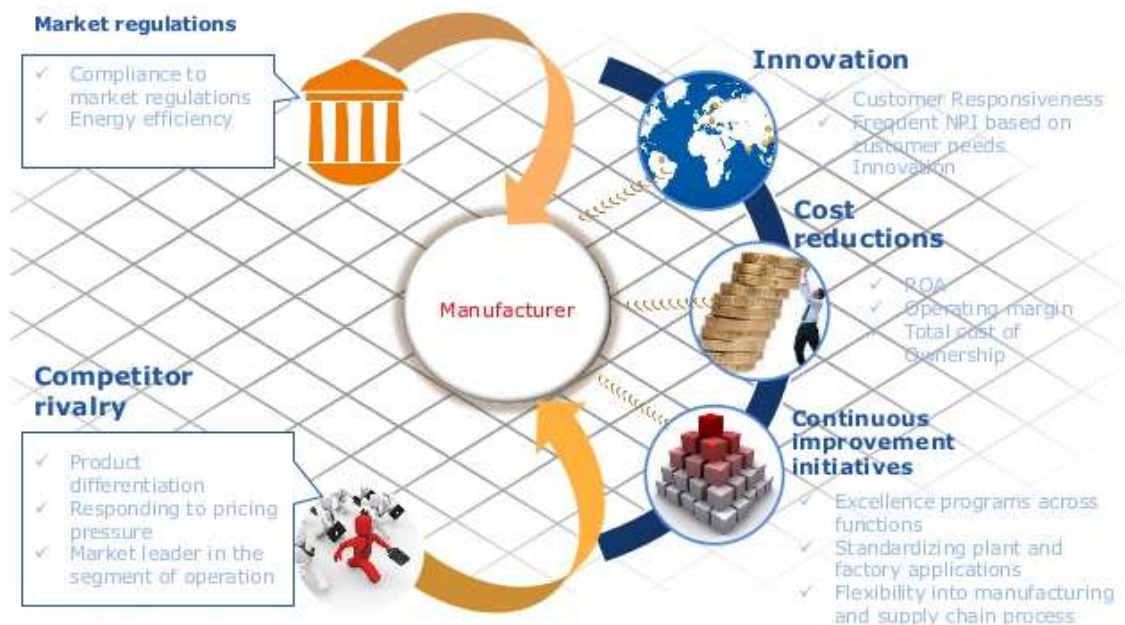

Source: (Mehra, 2013)

Figure 3. Global industrial pressure (source: Mehra, 2013).

The new competitors are emerging increasingly close to the classic leadership in the global market, occupying a space that allowed maintenance of social peace through the existence of jobs who maintained a social class self sustained and contributory.

2.3. The Potential of Industrie 4.0

The concern with the future competitiveness of German Industry is already inserted in the German Government Strategic Agenda by a few years ago. Since 2006 that the Internet of Things and Services have been promoted and accompanied with some technology programs with positive results (acatech, 2013). The potential developed by this type of strategy will allow the national industry to be able to develop procedures at the level of the competitive differentiation. Introducing the ability to satisfaction of specific requirements of customers in design, configuration, planning, manufacture and changes needed in productive systems all at the same time, makes possible the production in micro scale be profitable. This flexibility allows a dynamic configuration of different aspects of the value chain at the same time that combines an optimization of the decision model to cope with the real needs of the market. The capacity of efficient management resources, increasing productivity with the consequent creation of added value and ability to generate new business models by helping the employment market, will allow a better balancing of the social system. These will be able to create a balanced personal development in order to allow a greater longevity in the workplace with a continuous professional development.

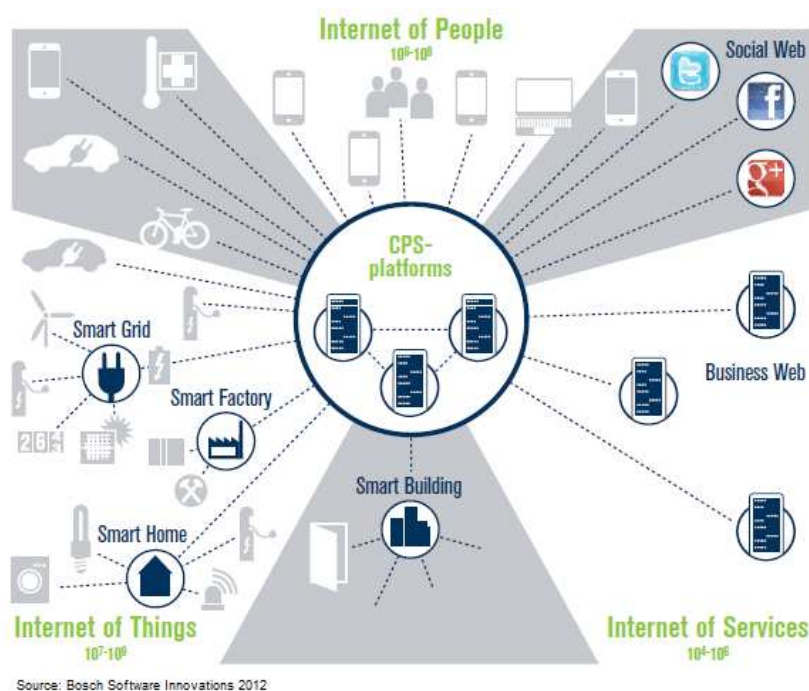

Figure 4. Relations between Internet of Things-People-Services (source: Bosch Software Innovations, 2012).

2.4. Germany and the new Industrial Era

The growth of the economy in Germany is dependent on the recovery of the World economy, the strengthening of confidence in the Euro and the relations with the partner countries for export of goods. They are still in recovery from last financial crisis and are not contributing fully to the growth of German exportation. So, there is an urgent need to find new markets for maintenance of growth of the internal economy.

The measures taken at the level of reforms in recent years, through the restructuring of the banking system and the German labor market has allowed a rapid recovery of the nation. However, for the purpose of technological differentiation, it means that should not be overlooked the need for investment in the specialization of new workers or creation of conditions for the maintenance of a long period of activity of most currently in service. This is refereed especially for the workers with skills able to create added value in new industrial working environment, dominated by digital processing of data by means of information and communication technologies, transforming the human relationship with the world of work and breaking with the known work methodology.

Germany, in parallel with other most developed countries, reveals the taking of initiative in the pursuit of objectives such as the demand for maintenance of leadership in some industrial sectors. In this way, the country will be able to maintain a stable economic climate in an increasingly volatile global environment which may put into question its social stability. This will compensating the natural transfer of industrial technology to the outside and will boost policies of differentiation at the level of innovation of products, services and technology platforms. It's a response to limited natural resources and at the same time maximizing the value added available created so as to maintain its leadership in the global marketplace (Westkämper, 2011). To ensure that this objective is achieved in full, the industrial companies must undergo for a change of mind set with the new Digital Era.

This mind set requires a radical change in the industrial structure, organization and operations models and it will not be the bet on mass production or in product diversity but, in the new paradigm of production. This paradigm is based and oriented to the optimization and creation of value on products throughout their life cycle with the consequent change in the manufacturing process of technological products which will require a redesign of the entire business model.

The amendment of the chain of industrial processing usually inserted in a line of operations, should be changed to the introduction of complex networks of production that

cross different levels and geographical spaces. These must be integrated in the production processes in networks of added value in a dynamic way and synergetic through a standardized global communication and enabling at the same time, the removing everything that is not necessary for production.

These new production technologies allow a permanent development in order to overcome technological limits in a continuous manner through the reduction of operating time, costs, raw materials necessity, waste generated, defects and energy consumption. These means, through innovative and self optimized solutions, will boost companies being ready for a rapid growth of this type of technology in order to create a competitive advantage in the global marketplace. This new way of operating in the industry will oblige companies to adapt their own structures as quickly as possible to be able to integrate all these industrial innovations increasingly complex so as to not lose competitiveness.

The response to this challenge has emerged through a present concept in a strategic initiative stimulated by the government in order to bring all the interested parties in a way that would share the same long-term vision. Also, it established coherent and targeted lines which would lead companies to pursue a common objective, establishing goals for a better monitoring and more rapid implementation. This will bring together the critical mass available for an investment dedicated to the innovation sector, capable of creating a high added value through the product engineering and industrial process that will cause the differentiation in markets available.

Networking in Manufacturing: Activating Potentials of Synergy

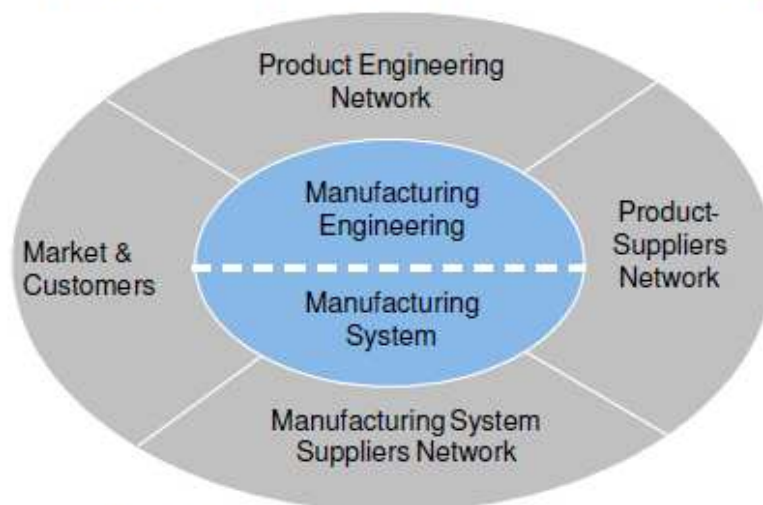

Source: Westkämper, 2006

Figure 5. Networking in manufacturing: activating potentials of synergy (source: Westkämper, 2006).

2.4.1. The National Strategy

Germany has not stayed immune to the global financial crisis that began in 2008. In spite of its rapid reaction to reduce their effects, has served as a warning to some internal weaknesses as also for the recognition of some external threats in the global market in the medium term with internal consequences. As an example, the loss of competitiveness for the emerging nations will lead to an inevitable decline in the labor market which will disrupt the social tissue leading to a loss of national prosperity. The response to this concern emerges with a joint initiative between all the interested parties for the preparation of a strategy. This strategy is capable of defining the technological direction of the nation for the next few years at the level of investment in research and development of innovative technology capable of maintaining the leadership in target markets.

The strategy is based primarily on research and development of innovative technological activities in eight key areas:

1. standardization and construction of a reference architecture for which it is possible an integrated value chain to the various national companies in a common network;
2. the ability to manage and planning complex systems already that the products and production systems are increasingly technological. The existence of these models could serve as a basis for managing this complexity;
3. the deployment of reliable and of high quality infrastructure for data transmission to the industry;
4. an investment in security in order to ensure that the production facilities and the products themselves are not a threat to people or the environment;
5. the reorganization of work environment through a technical and social approach in order to allow a more efficient personal development;
6. implementation of training strategies for a constant technological upgrade in the workplace;
7. organize the regulatory and legal framework of the new business models and innovations obtained;
8. an investment in improving the efficiency of the management of energy resources and raw materials in order to allow a reduction of operational costs to increase productivity (acatech, 2013).

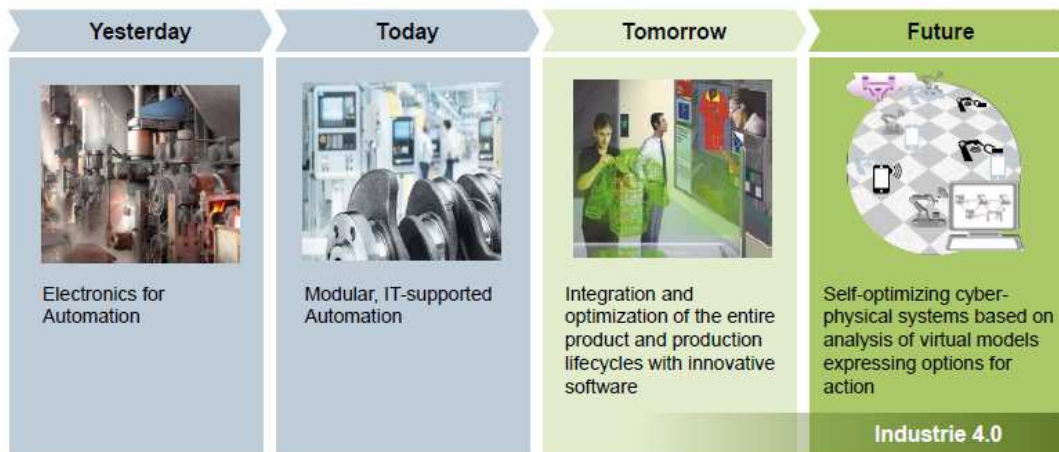

Source: (Bosch, 2013)

Figure 6. Shaping the future of manufacturing (source: Bosch, 2013).

The approach of this strategy focuses on the need for the stimulation of economic and scientific potential of Germany should be pursuing a common path in the meeting of innovative solutions geared for target markets. This is done through core missions engaged in a consistent sharing of information by all the technological partners and interested parties. This aiming is to allow that the nation is able to increase its competitive capacity so as to differentiate themselves from current competitors and the future emerging ones through the specialization in production areas of high added value. These strategies will become able to maintain a leadership status and at the same time protect its own domestic industry from the threat of volatility of global markets (acatech, 2013). However, this is a long-term strategy, and will have to be implemented in a gradual and interdisciplinary manner in strict collaboration with all stakeholders.

The strategy also includes technological development in five key fields of activity such as the climate and energy, health and nutrition, mobility, security and communication. This will also allow to create attractive conditions for the establishment of synergies between the most diverse technological partnerships for collaboration in research and development of solutions in order to allow raising the technological potential and commercial. (Forschungsunion, 2009).

2.4.2. The fundamental new approach

The strategy in course, discusses the introduction of a first widespread concept of national scope in which the interested parties, are involved and committed to a joint vision. This sharing the desire toward common development in areas of innovation, where all are accepting and participating in a strategic path toward the future, through the formulation of

objectives and establishment of goals to be attained. These result in the definition of priorities, by introducing new economic instruments and able to formal commitment in innovative alliances with focus on social dialog.

This new joint form of approaching a national common problem, was establishing a set of recommendations where must be accepted by all the parties concerned, to enable a rapid and effective integration of systems of innovation in the entire social and economic plan. This will allow also an internal self-regulation at the same time that interacts with all elements capable of producing innovation. This innovation will be in a standardized language of communication through all social, economic, political and industrial tissues, for the dissemination and use of own innovations produced (Carlson and Stankiewicz, 1991). As soon as the conditions are met for the creation of a capable dynamic innovation system at a national level, will become a key factor for the maintenance of a sustained economic growth, in any environment and market conditioning by competition, even the most emerging and with potential for development.

The changes necessary for the success of this national strategy requires the unconditional acceptance and sharing of all the interested parties through a common path. It will be allowed to insert the society in strategy by combining trade-related aspects with economic and social potential. It not will be allowed the fragmentation of economic sectors in an environment already conditioned by the presence of the variables of the market, competition and the legislator itself, where should make the process interactive and cumulative to exchange of ideas between the different elements present as creators, users and producers of knowledge and technologies.

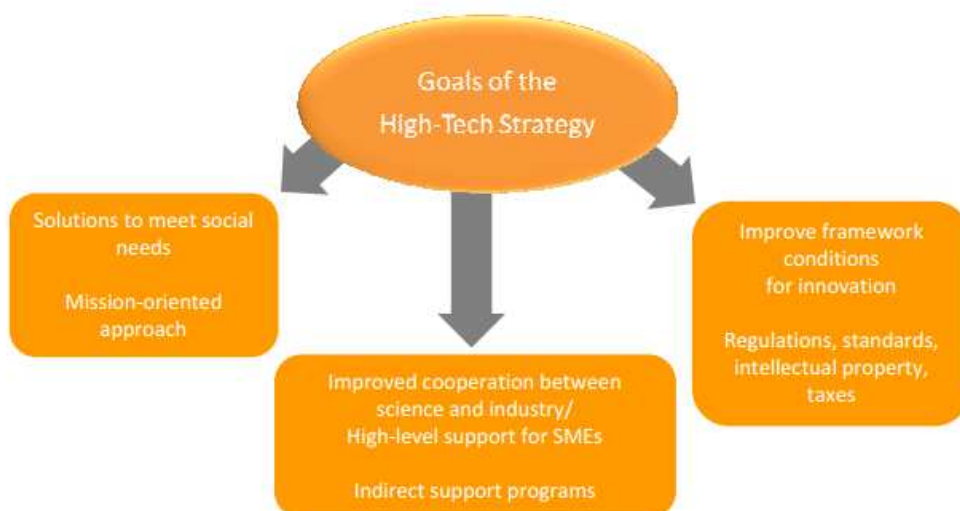

Source: (BMBF, 2010)

Figure 7. Innovation Strategy Goals for Germany (source: BMBF, 2010).

This approach in sharing common information will allow an exchange and analysis of vital knowledge to all interested parties to perform in the same way toward sectors recommended as the target markets. This will allow a technological development in continuous protection of national industrial fabric and as a consequence, the maintenance of social welfare.

The implementation capacity in society and stimulation of shared synergy of capabilities will make the difference in the performance obtained. This will be responsible for affecting national state of survival or maintenance of the status of Germany as international leadership.

3. Internet of Things

The temporal evolution domain of Internet of Things usually refers to a first phase between 1990 until 2005. The desired goal remained in a vision of miniaturization and integration of physical sensors with the objects of the day to day basis in such a way that are not visible and could be understood as computerized elements in a sensorial level (Streitz, 2001). The second stage began in 2005 (ITU, 2005) and is still up to the present day. The developments of the technologies that will compose this universe are the main concern in this issue.

Several decades that are being debated the possibility that the miniaturization and the ubiquity allowed through the use of sensors would altering the relationship between the human being and the environment (Weiser, 1991). This eventually would lead to the visual disappearance of computational elements in a constant presence in our day by day basis. Even after years of researches and papers produced, the Internet of Things while theme, continues to be a confusing matter and subject to the philosophical debate (Uckelmann, Harrison, Michahelles, 2011). All the work relating to this theme usually starts through a discussion of their previous settings and ending with self reviews of authors (Casagras, 2009).

Define what can be considered Internet of Things, does not bring a common standardization of terms or acronyms in the scientific community. But at least has a point in common: the use of technology in a universal form where have his omnipresence in day to day basis through the synergy developed between the most diverse objects and technological systems that share the transmission of information independently, interacting among themselves and with the human being.

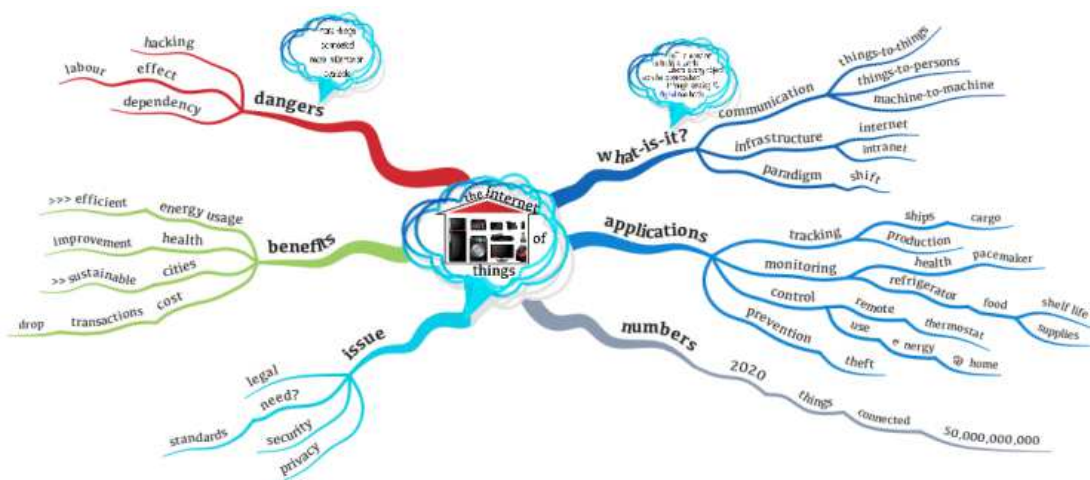

Source: (Agraval, 2013)

Figure 8. Internet of Things mind map (source: Agraval, 2013).

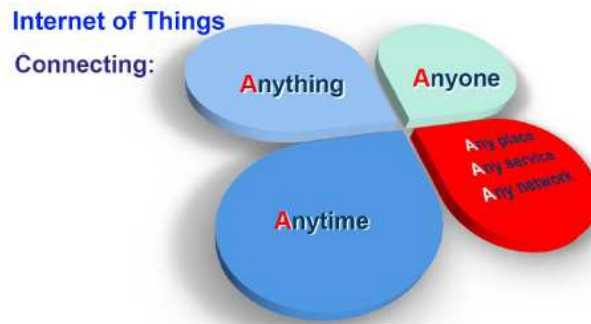

Source: (Vermesan et al., 2012)

Figura 9. Internet of Things: the 6 A connectivity (source: Vermesan et al, 2012).

Expressions used on literature diverse as Physical Internet, Industrial Internet, Ubiquitous Computing, Intelligent Environment, Machine-to-Machine Communication, Smart Things, among others, are all concepts that represent the same idea expressed here as Internet of Things. Also, merge into a common global informatics technology platform of networks like Internet of People, Internet of Energy and Internet of Services and others.

Internet of Things can be defined as a conceptual network of dynamic information of global reach. Its structure presents autonomous capabilities configurations that are based on standardized communication protocols, where the virtual and physical entities use of intelligent interfaces and are perfectly integrated. Also, its contribution lies in the increase of the value of the information generated by affiliated entities as well as the transformation of information processed as knowledge for the benefit of society (Vermesan et al. , 2012).

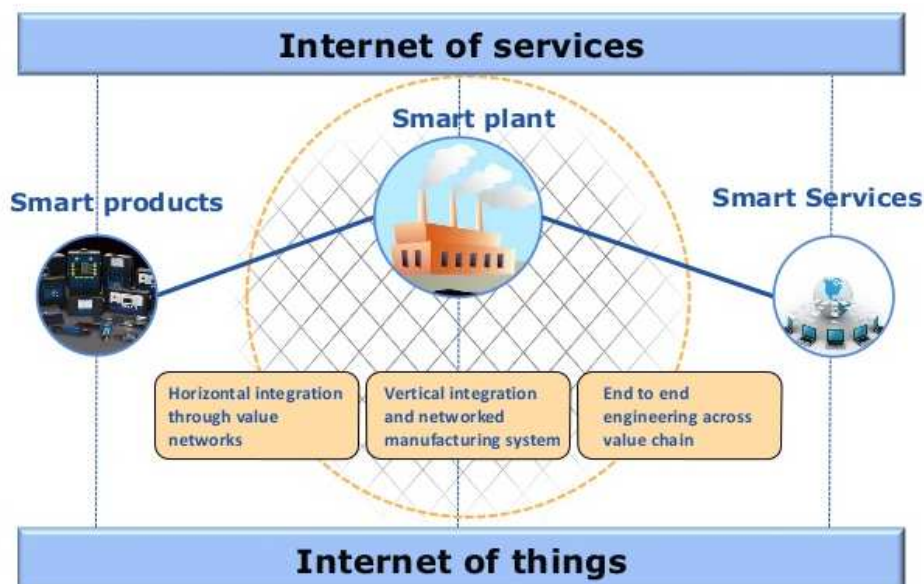

Source: (Mehara, 2013)

Figura 10. Internet of Services - Smart - Internet of Things integration (source: Mehara, 2013).

There is no doubt that the existence of the internet in today, has a direct influence on the economy of a country, in evolutionary impact of a society and how this prosperous through the acceleration of the transmission of knowledge. In the near future, these characteristics will have a greater impact like the integration of technological systems. This will depend on the connection in all levels of human society to have an accelerated development. Today still continues to be accepted that this type of technologies and their application are still in an embryonic state (Atzori et al. 2010, Miorandi et al. 2012).

At industrial level, this integration of systems will allow an interconnection of the digital world with the physical. The human being can interact with the appropriate means of production during the manufacturing process at the same time that monitors and controls the requirements necessary and specification field for the satisfaction of customer needs, by controlling the logistics units independently. This allows managing the entire management of the life cycle of the product or service in an instant way (bmwi, 2012). The union of industrial cyber physical systems with interactive software integrated with data networks global infrastructure reveals itself to be a powerful, highly flexible and autonomous instrument, adaptive to the environment, effective and efficient in their performance (acatech, 2012).

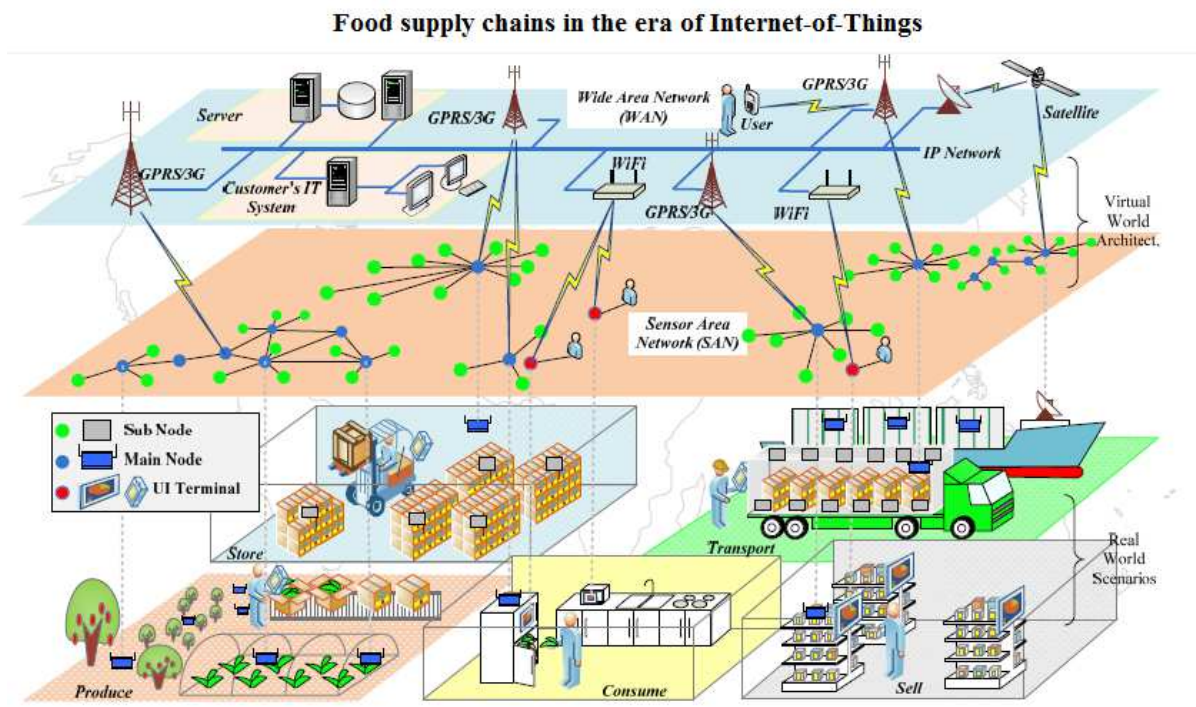

Source: (Pang, 2013)

Figure 11. Example of food supply chains in the Era of IoT (source: Pang, 2013).

3.1. Pre-requisites

For a successful and sustained introduction of this whole new technological industrial step, becomes mandatory and must be safeguarded the implementation of some pre-requisites in order to make possible the full integration and synergy necessary to the most varied levels.

Business Model

At the level of the business model, it is necessary to have a horizontal integration through the entire chain of value creation and business process integration. Providing an 'end-to-end' of engineering, allowing a vertical integration of the production systems where the manufacturing structures will not be fixed or pre-defined, but based on a flexibility that will allow the companies are able to adjust immediately their present needs in production. This new business model concept will obligate companies to reorganize themselves in the strategically mentalities and how to address to markets.

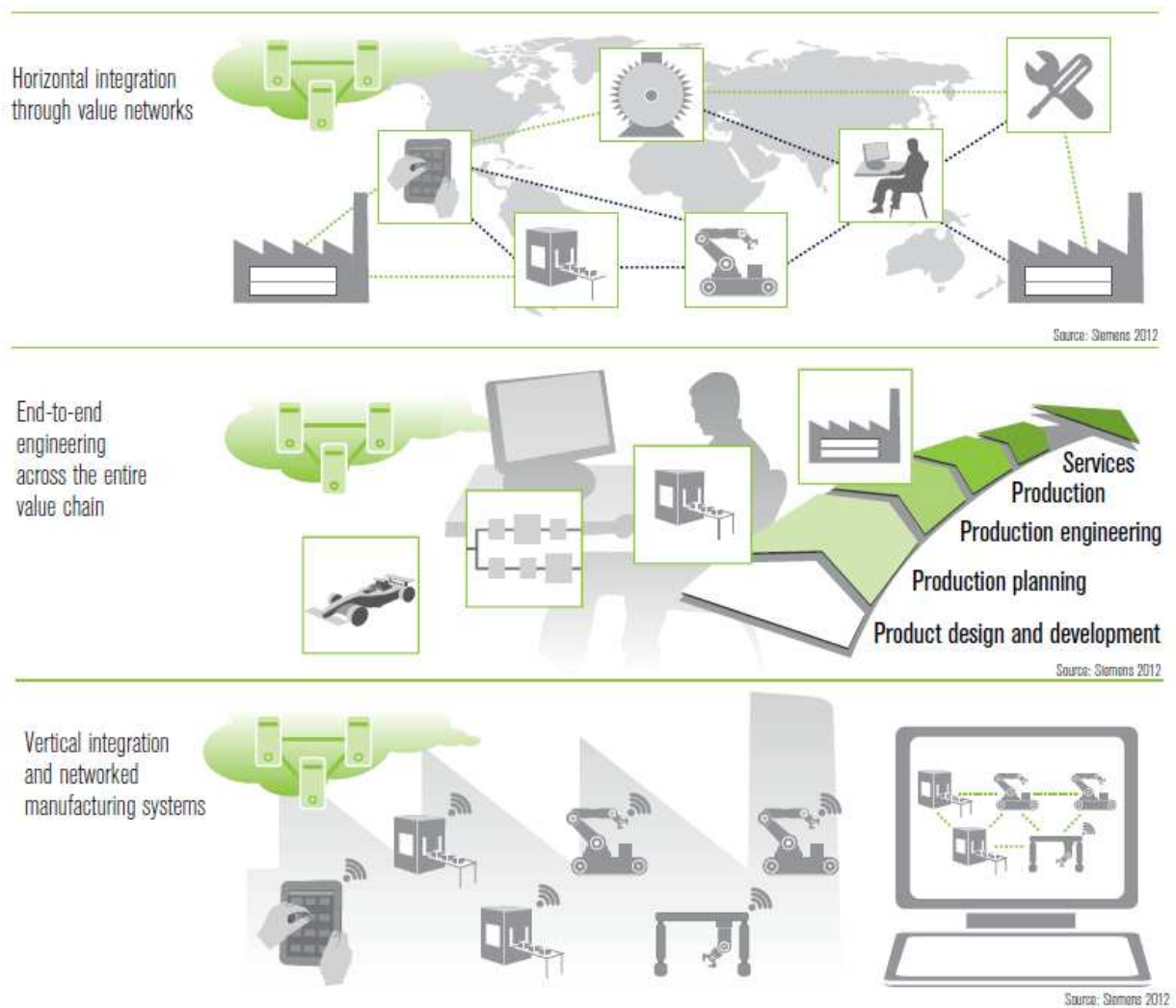

Figure 12. Business Model reorganization (source: Siemens, 2012).

Industry Level

At the industry level, the necessity on the structural technological development is to be incorporated in the development of technological products and services resulting from the investment in innovation. These should be made available to the market, with particular emphasis on autonomous systems allowing the operability among them and with the users through interfaces. All of the added value created can be managed and monitored in real-time and at same times decreasing the use of resources needed, by softening individually to production. This will decentralizing the system itself in such a way that it is possible to incorporate new forms of industrial cooperation changing processes for the creation of added value, by reorganizing their operations and labor tissue through the management of systems and complex infrastructures. This will allow a better integration and interaction of so-called Smart Objects, Smart Services and Smart Networks, also performing complex tasks in an autonomous cooperation by creating new prospects and control more speedy, effective and a capable way to create efficient industrial operational units. This need to manage in complex systems in an efficient manner for a correct implementation of this model, as well as the standardization of a common operating system between the various interested parties present in the field, allow the transfer of knowledge to which it must have as a consequence the possibility of introduction of new business models that will need to be addressed and designed by means of a normalized functional architecture.

Information Management

All this information must be reliable and available for use in service. Another pre-requisite with high importance is the establishment of a degree of security in such a way as to permit a reliable use of these industrial systems autonomous, by establishing a legal and technical framework for the more different social levels and industrial. Manage the information in a clear and secure manner with focus in open systems so that all could achieve the objectives and goals in common strategic policy development. This also avoiding or reducing the potential internal resistances and from the external sectors potentially dominated by lobbies. Accepting and recognizing a common standardization let's to be a potential obstacle or impediment to single project of cooperation with claim allegations in technical difficulties in communication. This is often supported by pressure groups in handling dependencies of data flows of supply upstream through the heterogeneity of unique software solutions that usually ends up causing an operating dependence in industrial systems, resulting in economic difficulties for companies that do not use open systems and

3.2. Reference model and architecture

A quick review of the current existing technological systems, allows understanding that the use of these products is limited to the use of internal systems, commonly called Intranet of Things. This due to its vertical integration, in which reference architectures fragmented without consistent universal concepts with solutions reached only allow specific applications where only abound many types of solutions which do not allow an interconnection and universal standard (Bassi, 2012).

Exist the need to create a generic model of reference whose application will allow the interaction between all the interested parties and interconnection in its most varied technologies in use. This by means of a standardized architecture framed and integrating the concepts, axioms, relations and requirements will be used as a path of common communication between all the entities (MacKenzie et al. , 2006). Is vital for the success of this new way of operating let all be generated from a model of reference base created that will promote a common understanding through a performance of interoperability at the level of communication and services among the most diverse platforms and systems. In this context, it can be noted that the management of information and communication technologies will be the key element in the context of factory of the future.

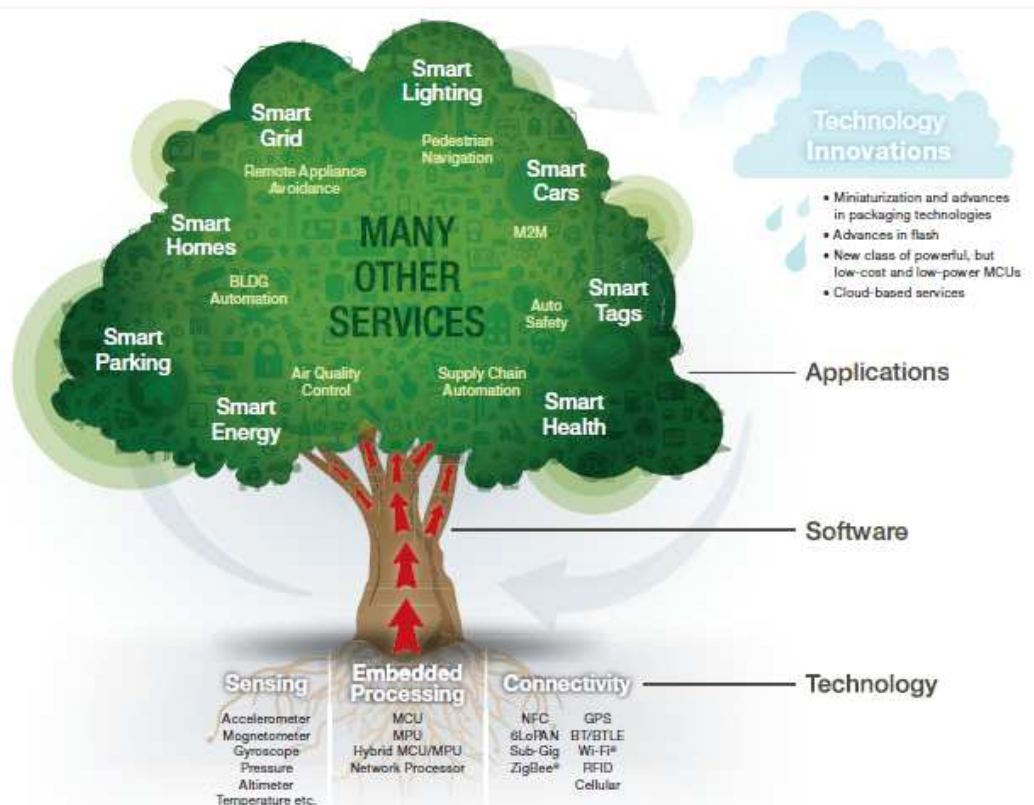

Source: (Karimi, 2013)

Figure 14. Metaphorical representation of the architecture model of reference (source: Karimi, 2013).

The drawing up of a reference architecture has already been addressed through explicit models proposed (Smith et al., 2009; Haller, 2010). Several researchers in the scientific community display substantial differences between themselves, perhaps due to the fact that they are working and researching through several development areas. However, in the context of research, there are still questions about the terms used for the reference model or reference architecture and should be the object of a quick explanation.

The Organization for the Advancement of Structured Information Standards, regards that a reference model is an abstract framework for understanding of significant relationships between entities. This allows the development of specific references or architectures using consistent standards and specifications to support work environment and education for all non-specialists. In relation to reference architecture, this should indicate how a set of mechanisms and relations allow performing a set of predetermined requirements. It must being an orientation for the later development of other architectures built, but with different purposes or goals. Also, it may provide guidelines in the form of best practices (IoT-A, 2011; Mueller, 2008). It becomes possible to affirm that reference models are basis for the reference architectures providing a better description abstract and inherent to systems and applications architectures designed for a particular application.

There are already several classifications of reference models relating to the domain Internet of Things (Haller et al., 2011). They are distinguished in models of devices in physical world interaction sensors, entities for context aware applications, technologies for automatic identification, ubiquitous computing and also real world service oriented architectures. Any reference model that is being actively used is continuously being subjected to changes and improvements.

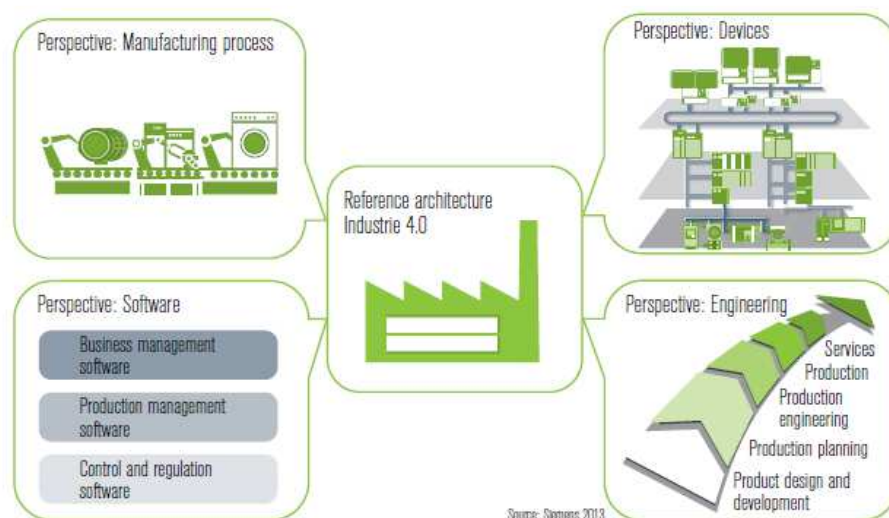

Figure 15. Generic reference architecture to *Industrie 4.0* (source: Siemens, 2013).

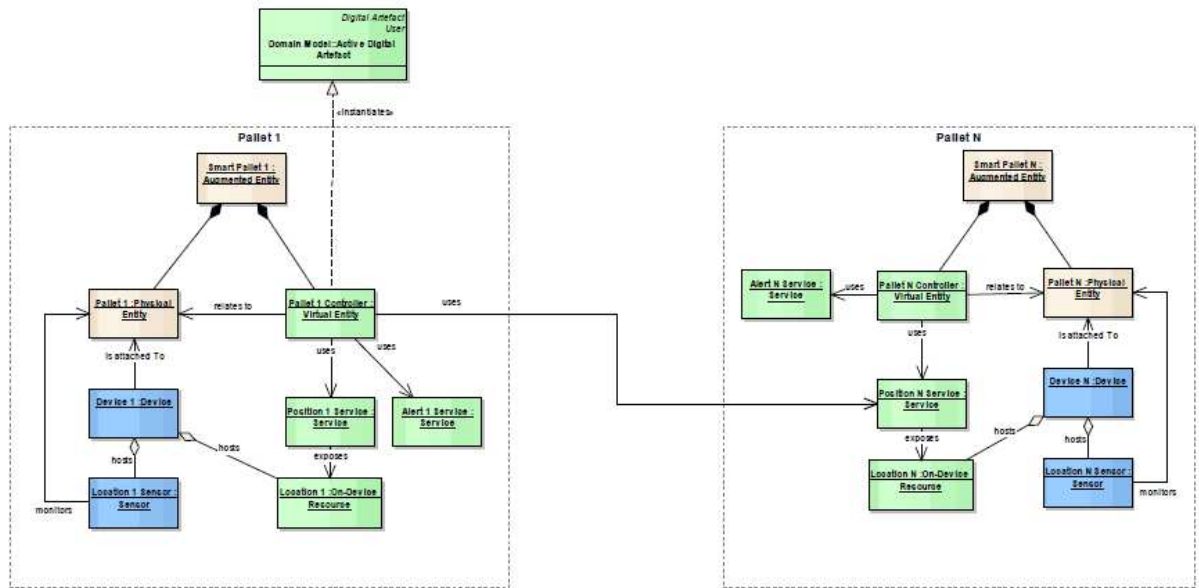

Figure 16. Smart Pallets modeling (source: Nettsträter et al., 2012).

As an example, it can be mentioned a case of common application in the management of the supply chain through the movement of pallets in logistics with the system Radio Frequency Identification tags based on Electronic Product Code (Nettsträter et al., 2012).

A pallet contains several boxes that are physical entities of interest from the perspective of the application. These are related with virtual entities that represent the digital world in the form of database stored in a network source where it is exposed to queries and updates. The human user can use the application as interface to check the status of items to trace and locate (pallets and boxes). This scenario described is a typical communication scenario from Machine to Machine, where the intelligent pallet that represents the physical entity and a control program that represents the virtual entity interacts with the service.

The use of a model of reference architecture provides several types of benefits. It can aid in activities of product development to guide lines of discussion between all the involved due to the use of a common language. This also allows the integration of new participants in this field like the independent developer of projects for construction of modules of blocks of work in deployment of this type of intelligent systems. Above all must provide an effective common basis capable of capturing the largest number of possible advantages by establishing a definition of entities present on the Internet of Things. These must describe their basic interactions and relations in such a way that all the following work is carried out based these common concepts.

both directions of communication. This supports the transmission real information and permanent the whole network of support ensuring that entities to control for sharing of information, even in the form of fragments of most varied of emission sources, allow an effective monitoring. It must be guaranteed the design of a common standardization capable of satisfying the most different requirements of all sectors of industry present and at the same time ensuring access to integration of all interested parties. This can be done by means of a consensus, platforms and interfaces of understanding in a common way as well as ensure encodings that will avoid ambiguities or different interpretations resulting from errors or different forms of communications on human language.

Its design must accept the need to use energy efficiently and network capacity as well as other restrictions such as legislation in force, frequency bands and emission levels for frequencies of radio communication. These restrictions may limit the full potential of its development.

3.3. Cloud computing

The Internet of Things will inevitably have to deal with all these issues already presented behind and there is an assumption in scientific community that it can use the features of cloud computing to manage, store and process a virtual processing platform.

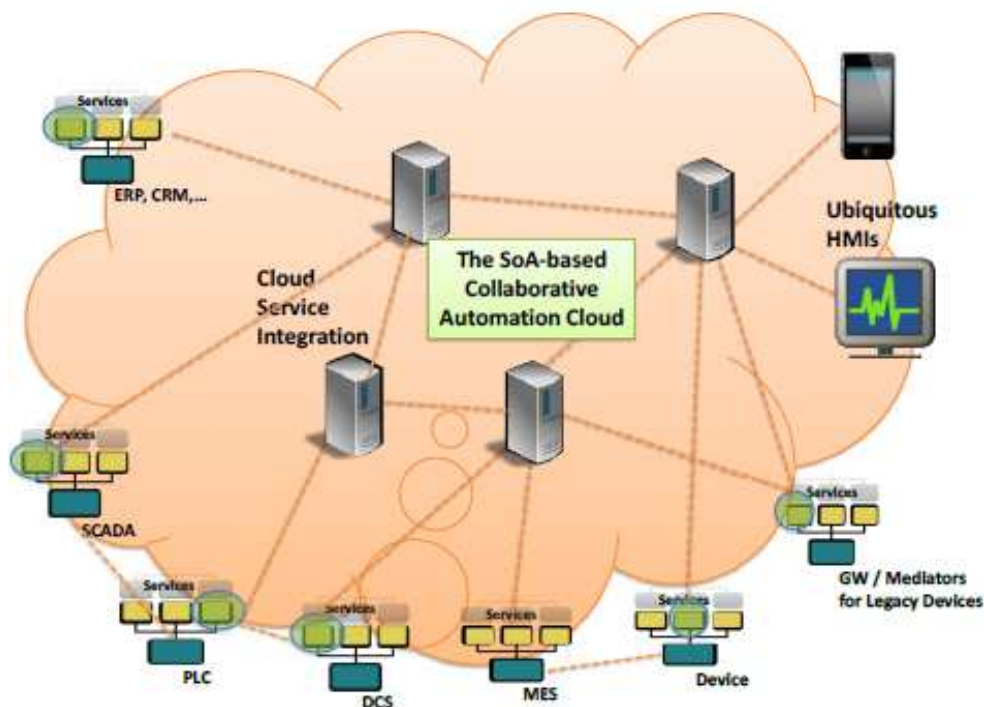

Source: (Colombo, 2013)

Figure 18. SoA interactions and the behavior of the CPSsystem of Systems (source: Colombo, 2013).

In this respect, this type of platforms already may offer a support in this flexible management of the data of the most varied sensors.

Cloud computing is one of constructive blocks in foundations of the internet of the future which can allow the management of all these systems in a dynamic manner, swift and comprehensive, in the most varied volumes and ratios. This interaction reveals a change of paradigm in the integration of the use and application of different systems. The new generation of applications in the industrial area can be quickly generated through the selection and combination of new services and capabilities to the achievement of its objectives and tasks, which are on offer in this system of cloud. Those are being dynamically allowed and accessible to other subsystems of industrial management. These services can be organized so as to allow a structured access to involvement and integration through an evolutionary behavior and collaborative functions in automation. Also, it can be configured for the maintenance of independence at operational level and management of system components.

The next generation of Architecture Systems to interact with the System Cloud will have to have the capacity and autonomy to ensure an independent operability. This can be achieved through features that are allocated in autonomous subsystems. It's necessary an independent management of operational components allocated and distributed in cyber world with a behavior based on their physical and digital properties, adapting it in an evolutionary way and flexibly to external and internal events generated by the environment or by all interested parties.

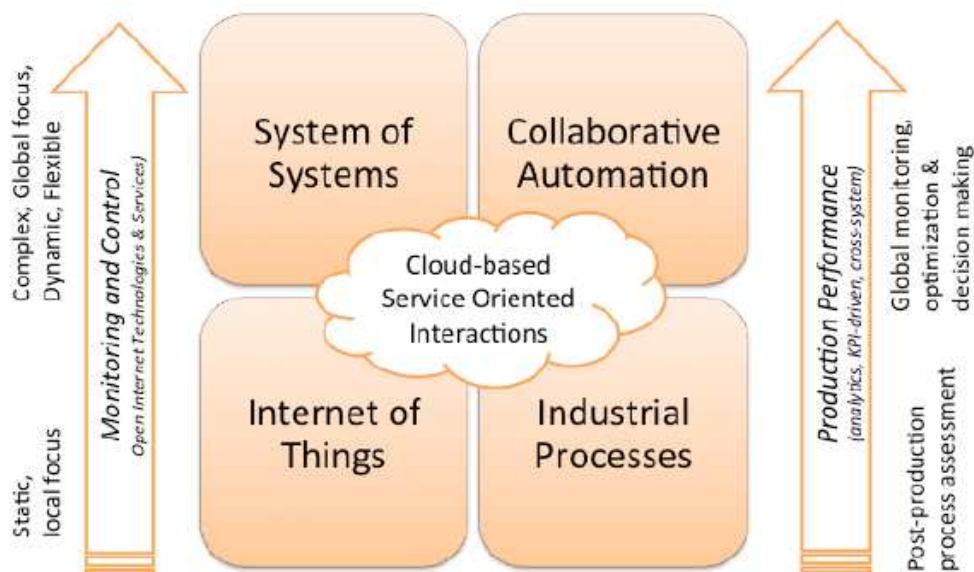

Source: (Colombo, 2013)

Figure 19. Cloud based Service Oriented Interactions (source: Colombo, 2013).

3.4. Internet of Things in industrial production

For industry achieve creating technological differentiation, it becomes necessary a reorganization of the entire industrial methodology. It is possible to increase its operational efficiency through the efficient management of its resources, reducing the time of entry of the products increasingly more complex to produce, in the target market to achieve. With Internet of Things, industry acquires a new flexibility that permits an individualized production in large scale with a high level of productivity where the product to be produced already contains all the necessary information (Siemens, 2013). The role of the human being as generator of creativity, planning and decision-maker will continue to exist. He still is the center who can conceptualize and design new products and complex systems, determining their parameters, rules and requirements inherent to this type of complexity.

Industrial benefits and value creation using Internet of Things can be achieved with a contribution for the global benefit of the company. Some are as visibility and identification of products and hardware, location tracking in manufacturing and supply chain, contributing for safety in dangerous environments, reducing production losses and energy consumption with an efficient management, allowing new type of processes. These and also a new type of long-term maintenance approaches will create sustainability at all levels (Vermesan, 2013).

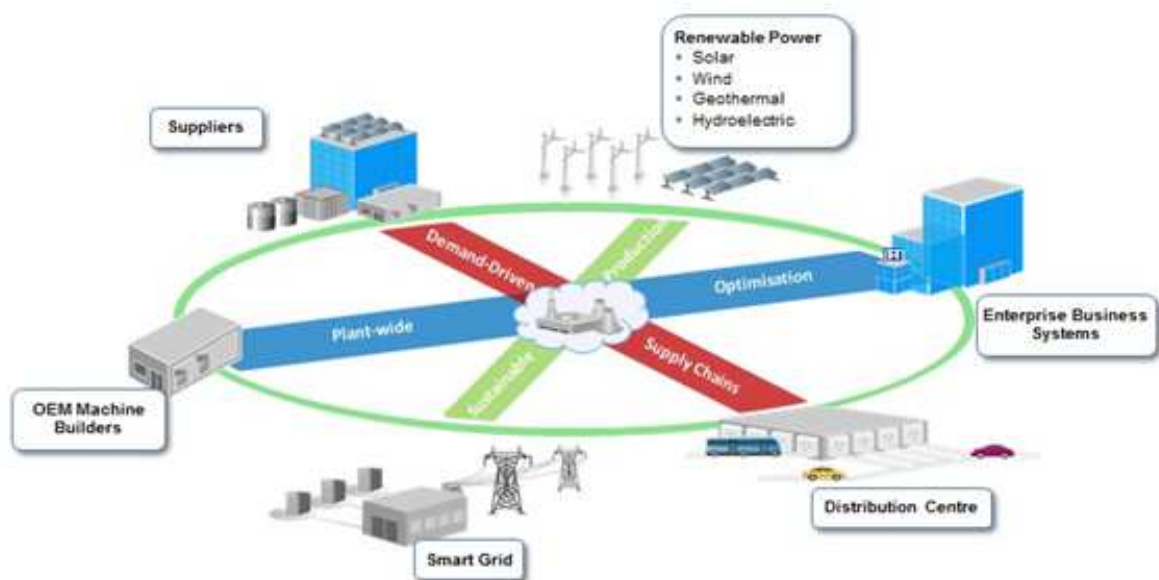

Source (ABB, 2013)

Figure 20. Industrial Smart Integration (source: ABB, 2013).

4. Cyber-Physical Systems

Identifying the differences between the Internet of Things and Cyber-Physical Systems is not an easy task. In the scientific community, the boundary between these is not defined clearly. Both concepts were generated and developed in parallel by means of two independent communities, often considered until as synonyms. With the Internet of Things, some communities have a clear bet in RFID technologies and are for communication technology management (Koubâa, 2009). In Cyber-Physical Systems are addressed for industrial integration production systems purpose.

In a simple and generic way, it can be defined that the Cyber-Physical Systems, are systems allowing to humans performing complex tasks requiring a minimum of suitability and specialized education. These systems are more efficient, productive, intelligent and using computational capacity. Their physical components allow integrating and interacting with the real world in a temporal and spatial scale to capture and processing data, using the Internet and Cloud Computing for a dynamic communication between the elements in connection (NIST, 2013). This occurs via integration through software embedded in each system or physical component, working in various communication networks, at the different levels and multiple scales in a dynamic way. It's performing and reconfiguring adaptive capabilities with a high degree of automation and control ensures the reliability and security of the system and operation.

Characteristics

The system should be autonomous and self regenerative. It must being based on knowledge of the productive system in real-time and sensitive context. It should allow that local and decentralized memories in productive equipment and in the products themselves, can collecting, store, review and distribute detailed information about the entire production cycle, energy management and other requirements relating to the management of production (Spath et al., 2012). This must aim at a more flexible use of the factory infrastructure in the reduction of time production and to achieve objective zero stocks. This way can meet the need for customization of the product compared to the satisfaction of the requirements of the Market (Rajkumar et al., 2010). So, in this context, it can be said that Cyber-Physical Systems are integrations of computation and physical processes, interacting in a dynamics continuous time and discrete events (Lee, 2008; Zhang et al., 2013).

The computing and the existing networks currently, does not have sufficient capacity to improve design of processes at a level of abstraction. The passage of time in the physical world is inexorable and intrinsic, making it necessary to redefine the abstractions to the level of computing and networks so that they can unify the physical process with the computational to create a hybrid network of improvement in performance.

Could be listed more characteristics especially if addressed to each sector of the industry in question. However, it will be presented here only some basic characteristics common to all for a general understanding. In this context, these systems will be based in concepts on cybernetic, engineering and human life for a harmonious integration of its components. These allow the use of synergies available in order to be efficient, effective and safe during its use in need to provide a learning capacity and updated information for an efficient support in decision-making in an autonomous manner. Its open architecture and common standardization, will allow a greater flexibility and adaptation to a customization of production even more complex and dynamic at various levels. This also provides basis for a management of more complex systems, making them more resistant, resilient in various levels (NIST, 2013).

The main characteristic to take into account should be the creation of an infrastructure able to meet a wide variety and heterogeneity of inputs from sensors and also outputs from actuators. At the same time, enables through displays an interface with the most different potential users, allowing different systems can coexist and interact among themselves in a same frame of architecture.

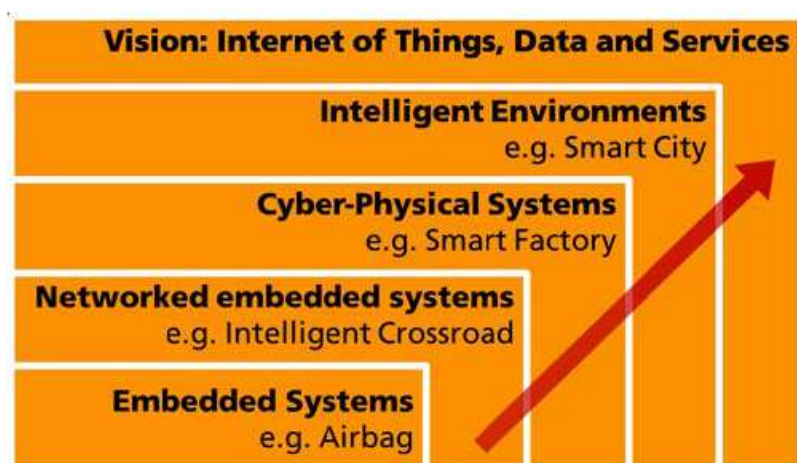

Source (Spath et al., 2012)

Figure 21. Evolutions of the concept (source: Spath et al, 2012).

4.1. Pre-requisites

Setting pre-requisites while the systems engineering and software community itself still does not understand all requests needed due to its dynamic behavior, makes difficult referred them in a representative common agreement frame (Zhang et al. ,2013). However, some are proposed already in evolutionary sequence in development in this area.

The necessity of being open design architecture, modular and extensible to update, will permit utilization for the entire spectrum of its potential users in the most varied conditions of operation. At the same time, should allow a monitoring and effective traceability where access should be guaranteed in a secure way, supported by a solid model and robust.

These systems will have to accommodate a large capacity for management and integration of information. These systems also must have capacity for repeatability of the action at the same time that supports an integration of affordable new technologies and capabilities. Everything must be done in a collaborative environment for handling data in a continuous manner without the need to restart or abandon the system to perform the process (Campbell, 2007). One of the main requirements must be their need for if they reconfigured dynamically and autonomously due to the need to adapt to the continuous changes in their operating environment.

4.2. Reference model and architecture

Several difficulties contribute to hinder development in the field of Cyber-Physical Systems.

One of the main is consequence of the lack of a theory able to establish and manage their several resources in a single and unified frame. This frame must be capable of integrating the operational technology and all technological information through its various levels of abstraction. These levels can make them capable of displaying a self-adaptive behavior in a conservative way and allow a capacity for learning through their multiple domains (SUMMIT, 2013). This requires that these types of systems must be secure, interactive with open interfaces to all interested parts. These also allow a better integration while elements and components with ownership recorded may be used, reaching a multiplicity of systems. This is opposed on use a huge modeling language by means of an abstract semantic, through a multiple form templates, with dynamics discrete and continuous in a parameterized form (NIST, 2013).

Platform

The global platform must allow interoperability able to authorize a negotiation of automatic functions and capabilities through architecture with guidelines targeted for communication and value added. This must use abstractions integrating multiple aspects as the functioning, behavior, quality of service and control among others. Practice through the connectivity of its components in the way plug and play should producing predictable results even when elements are subjects to unpredictable interactions. This must support the capacity of automatic reconfiguration of architecture in response to failures and aging of their own components through networks of multilevel security.

Intelligence and Cognition

Cyber-Physical Systems must incorporate the ability of recognition and understanding of the intentions of its human operators in real-time. These must be done through components that could act as autonomous entities using a natural language and integrated with the various information in circulation interconnected on a basis perceptive and cognitive. This allow to perform the desired action through the operational knowledge not enabling real-time decision making if and when may violate some restrictions in order to protect others. The use of multidimensional applications that can interact with the real world will induce the sharing of knowledge of the most diverse areas. Stimulating the development and processing of communication between elements are not factors limitative of the majority of required applications and integrating technologies. These also must be developed in synergy with a security measurable and predictable in the systems to process and manage huge amounts of data from information in an efficient manner and optimized.

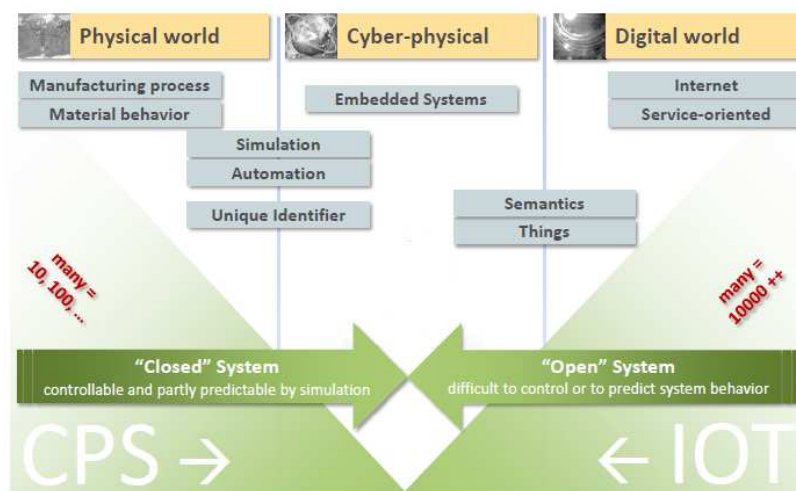

Source: (RWTH AACHEN, 2013)

Figure 22. Integration of CPS and IoT Philosophies (source: RWTH AACHEN, 2013).

4.3 Difficulties to overcome

The complexity of Cyber-Physical Systems, when compared with traditional systems presents numerous difficulties that must be overcome to achieve a streamlined and effective industrial use in operation.

Modeling

The complexity of the models of systems necessary for sectors such as the automotive industry, aeronautics or energy obligates the need for models that incorporate the dynamics of the physical system with its controller. This action requires that these systems must be an abstract representation where the level of abstraction is driven by how the model will be used. This means that scenarios must focus only on actual behavior on the level of correct abstraction, having as a consequence the need for creation of modeling tools that allow the controller may imitate the physical task in virtual form.

Time, space and complex dynamics

These systems will have to operate through a defined behavior in terms of time and space. This requires that computing must execute answers in real-time. Will be needed resetting a new form of notions on this subject in such a way that can integrate the requirements of time and space in a uniform way. This will require a development of this interaction with their functional dependencies in the location of the operating platform and its respective surrounding environment and the number of elements presented among other operational requirements. This dynamic behavior will have to be captured in hybrid models of systems in a manufacturing process. Their dynamic behavior between the most diverse cells presented will have to communicate and organize among themselves in an optimized way.

Non-Functional Requirements

One of the difficulties of interpretation of non functional requirements is located in its subjectivity and importance attributed, allowing varied interpretations and evaluations because they are subjects to a human analysis. This human dependence may have as a consequence a harmful or even beneficial way in range of another non functional requirement necessary for the development. Thus, in this context, the evaluation of the dependence of a system must be analyzed in its basic variables such as trust, security and maintenance of the system itself in real-time. The failure in the operating environment may entail enormous and irreversible consequences to the system in use.

A wide research in articles reveals that some methodologies and tools have already been proposed for a design these systems. In fact, they are still in development because at this stage we still do not have a complete and real understanding of the requirements needed for an optimization of the complex dynamics of Cyber-Physical Systems.

Verification, Validation

Understanding how a methodology can be developed to permit the verification and validation of the entire system will be one of the difficulties to be overcome. Increasingly complex systems depend on several elements at stake that due to its complexity and broad involvement, it becoming necessary for the application of all the phases of these systems since the design, testing, deployment and operational in continuous. An added difficulty is revealed in perceiving than human interaction of this issue may become a barrier to a common understanding on this issue. An operational predictive specification it becomes vital to prevent actions incongruous of system operators. These may disturb the quality of evaluation and validation of the action in progress. Enabling these systems can perceive the capability of recognizing these error intentions is necessary. The human operators will continue to be part of the production system as a whole. This requires a new quantification of the potential failure mode in addition to the basic determination of tolerance 0 or 1, but one that can include and assume a risk behavior potential, as well as the determination of the degree of risk in their own analysis.

Software

The traditional capacities of the programming languages and methodology are not yet capable to provide a support base for all the difficulties and challenges already identified for the Cyber-Physical Systems. New paradigms at the level of computing and programming languages will be needed to establish a correct structure capable of managing the complexity required by these systems. The software will be dependent on the hardware platform, making the entire productive cycle involved must react as a single entity to be managed in real-time. This requires the design of a new theory of control over the behavior of the whole manufacturing plant as an integrated dynamic model that cannot be dependent on failures with origin in software. Currently, represent's a difficulty already that do not exist yet real connections and crucial control between failures with origin in error in

computational conditions potential, which will require a survey about what really is the reasoning of computing in a vertical integration.

All these implications will have consequences in all levels of society, through the result of its impact and acceptance of software in critical aspects of design, verification, validation, usability, privacy, trust and fault tolerance (SUMMIT, 2013).

Security

The fact that these systems are composed of cyber and physical components oblige the development community in taking special attention in relations as the security of the system. As both elements are likely to fail, the failure of one can directly affect the functional capacity of the other in the most varied and complex forms, displaying up to unpredictable behavior especially in systems that operate in real-time. These failures can be caused also by outside intrusions with criminal intent to disrupt the proper functioning and operation of the system (Mok, 2103). Becomes critical designing these systems in a resilient way, especially in more critical applications. This requires that the Cyber-Physical Systems should being able to adapt to the physical environment by protecting the operability and data integrity even when under the effect of failures or external intrusion malicious.

5. The challenges

The major difference of this technological New Era in relation to the past lies in the fact that is still continuing to scroll through an evolutionary path for the improvement of technological processes. This results in a consequence speedy result with creation of new technological structures potentially more effective. Thus, in this context, the technological management will face a strong pressure especially with regard to a structuring and development of an operational capability. This enables the efficient management of increasingly complex systems that manage connections between components and equipment. This is one of the most complex challenges that will to be overcome in order to create and implement a type of operating system that is actually operating as a whole. All intelligent equipment created can interact and be integrated among themselves and with the physical environment that surrounds them in an independently form. This form of integration will oblige all interested parts to reinvent their classic academic disciplines for the need of transition, fusion and integration in the new models and simulations in productive processes. These require a reformulation of knowledge at various levels dependent on industrial factors such as the applications recognized by operating units, the management of configuration options and framework conditions of manufacture. All geared for a customization of product resulting in an interdisciplinary combination. These with the inherent costs, logistics, security, reliability, time of production, the use of resources in an efficient way and sustainability oriented to demand the satisfaction of the need of the human operator.

5.1 Challenges for engineering

The engineering in classic format is suffering a trend to combine the capacity of innovation on the function of the materials with the evolution of manufacturing processes and production systems. This synergy creates new opportunities in the field of creating substantial added value to be able to decrease the cycles and times of production by reducing operating costs and eliminate the errors committed.

Another of the challenges of engineering is included in the need to create and develop models that allow for the development of technology areas such as the physical recognition. This should be able to recognize and understand the objects, execute an advance planning in whole or in part in an autonomous manner, being able to cooperate and negotiate with other sources of knowledge and innovation at the same time.

Developing a capacity for self learning in relation to the surrounding physical environment through the development of protocols and strategies of self organization with the creation of risk, conflicts and processes models, allow the analysis, validation, improvement of processing speed by integrating technologies. The integration of a monitoring, control and effective supervision of functions such as learning and the establishment of protocols of practice in critical situations by compensating for deviations, will be necessary conditions and inherent to the intelligent products in productive systems (Bessey et al.,2009). These will be as a challenge to the ability of creating productive equipment and self adaptive in optimized structures in real-time. Based on modules of Mechatronics, where knowledge reaches in multilevel modeling techniques of control, through cognitive structures and actuators supported by a high-level of redundant systems should ensure confidence in the system and an optimization of the performance of the production system under the most varied conditions of service.

The use of digital technology combined with the modern production processes through the integration of computer technologies in modeling, simulation and testing capability in real-time has as natural consequence the revolution in process of productive flow. Integrated Technologies such as Computer Aided Design, Computer Aided Manufacturing and Computer Aided Engineering will allow a close connection between engineering and industry in its productive systems. Through the union of synergies in research, development and production is starting to be available for production achievement in physical spaces in different geographic areas. This also allowing a decentralization of production and at the same time the replication of any research center or industrial installation in its full capacity in any location strategically desired. This must be accompanied appropriate technological infrastructures of support, necessary to ensure a correct functioning. These conditions allies to productive processes such as for example the Model Base Definition and the Additive Manufacturing System among others, will allow a productive approach increasingly personalized, flexible, fast and dynamic. This allows being able to meet the needs of the market at the same time that significantly reduces the need for investment of financial capital and resources to build the classic infrastructure and supply chains. These new productive systems, allow reduce the costs involved in the whole process for the implementation of a line of conventional production at the same time that allows a customization of product combined with a production of fewer items, making it more competitive.

The most immediate challenge that engineering will have to tackle in the near future will be the development of new methods of searching, processing and transmission of data. The exponential increase in the volume of collected data and their processing require a quantity of energy consumed increasing. This will be mandatory to find new formulas for energy management mainly for use in the apparatus and intelligent systems, increasingly miniaturized and close to achieve its own limit of volume reduction. The engineering will have to be able to manage aspects creators of innovation at the level of energy in a global trading level. Its conservation and use in integrated areas such as nano and microsystems allow being possible to use physical entities of very low consumption in the level of intelligence capabilities such as the self-consciousness and environmental perception. The intercommunication between machines can be made in an autonomous manner and secure with the development of new forms of intelligent and data acquisition recognition. This information allows being possible to integrate into new systems of communication in order to use different interfaces in varied applications and integration of technologies for identification, inclusion and integration of communication networks. This will ensure reliability in the infrastructure to the level of security and privacy in use of information through the ability to recognize a personal identification of billions of equipment heterogeneous using technologies of different communication. The development of applications and equipment should allow easily be linked among themselves to conduct an exchange of information in an autonomous manner. The large-scale modeling systems concept must comply with a common standardization and ensure a seamless interoperability among all entities present through a clear and universal integration of the requirements for a global identification. (VTT, 2013).

Concerns

One of the concerns to be taken into account may be allocated to the limited financial capacity for investments of some industrial companies. This aspect may become worrying and put obstacles in accession to the common strategy toward innovation. It may oblige to make amendments or internal operations which could put at risk the investments already made in assets such as equipment, physical infrastructure and also in human capital that has been a pillar of success up to the present day.

This new systematic approach requires consideration of the ecosystem of the market as a whole for the technological opportunities create a key factor for market leadership. In this context, it is necessary an agile, dynamic and effective articulation among all interested

parties through stimulating a new way of living and thinking in the industry. In industry, many companies still use a vision that the corporate strategy must be based on first step in the designing a product, service or technological process even before consider what market were want to insert it. One of the problems with this strategy today, is that this may no longer be effective enough to be able to identify and capture new opportunities and market trends with effect creator of value added increasingly limited. This because the full satisfaction of the requirements desired by segments of demand in today's market, is increasingly more competitive and global.

One of the errors derived from this lack of linkage may be committed in some companies that tended to focus on a perspective of creation and development of the act of innovation through use only their own resources. These when insufficient for the tasks in question may disperse potential synergies with external partners in order to share risks, the costs and the gains. This attitude is mainly for fear of not being able to maintain a position of dominance in the monitoring of the innovative process leading to that often, abandon the joint project in development phase with the resultant costs for all parties.

5.2. Challenges in industrial environment

One of the biggest challenges that the industry itself will have to overcome is reflected at the level of getting and streamlines an effective interoperability between the products, the infrastructure of production and their processes, their controls and direct applications. All of this through the use of information and communication technologies, in an autonomous and independent manner through methodologies, tools, and software capable of synchronizing all these elements ensuring a consistent and secure exchange of information of data. This represent an exponential increase in the complexity and volume of transmitted present data which oblige the industries to upgrade their technologically at all levels, including the organization to allow the management of complex systems in an efficient way and not saturated. This way it can improve a competitive performance competition in such a way that each element will receive only the desired information and individualized to complete its task characterized in physical information converted and processed into a digital form (Sauer, 2013).

5.3. Challenges in Industrial Security

One of the items most tricky and objects of greater reflection should be the guarantee of formulation and implementation of a security level capable. This must be capable of creating comfort to users of productive systems and vehicles of information transmitted to full acceptance of all the interested parties. Incidents of invasion of privacy may cause serious damage since the miss of capacity of the system in use, decrease of productive performance, manipulation or loss of information, risk of damage to the infrastructure or productive tissue among other that might call into question the financial health of the company. A concern inherent to its common architecture reflects the need to constitute a differentiation in the model between the securities for the industrial environment of the other standard. This way it becomes necessary that the productive systems must have ensured a constant operability in real-time, performance and protection in its data base of information available throughout the value chain.

Not only the physical infrastructure of the plant must being effectively protected, but also the operating network and all integrated systems with awareness that security in industrial area only will result in an effective manner if there is a synergy between the collaboration between all manufacturing operators, system integrators and manufacturers of integrated components. This will be possible only if there is a management process that ensures for example, a contemplation of a risk analysis that permits emphasize the necessary level and create a form to be able to reduce to an acceptable level. At the same time, it must allow for the elaboration of policies and measures in accordance with the technical goals to achieve, in order to validate and improve continuously (Siemens, 2013).

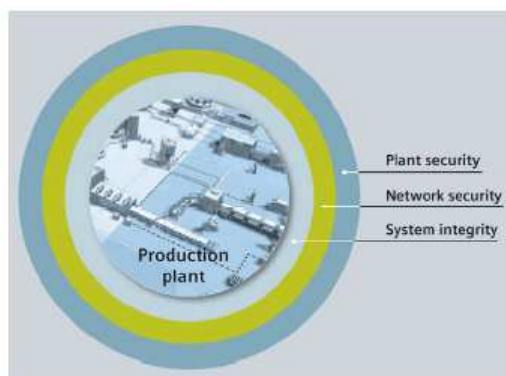

Source: (Siemens, 2013)



Source: (Siemens, 2013)

Figure 23. Levels of industrial security (source: Siemens, 2013).

The management of industrial safety should not be seen as a mere question of technical implementation, but should be understood as a need for integration in a process of continuous task. This task must depend on the type of risk associated with the systems in use beyond adopting and maintained organizational measures and appropriate techniques in close collaboration with all the parties involved.

5.4. Challenges in the new decentralized production philosophy

The new philosophy of decentralized production has its basis in the technological collaboration through an operational network. The classic physical space already is not crucial to the competitiveness of a company to be productive in an economic way. In its replacement will be implemented the integration capacity of a level of technology with the consequent virtualization of the entire structural environment by introducing a new concept, the existence of a virtual factory. This virtual factory should have the capability of managing the systems integration with logistics and supply chains through productive systems prepared and organized by providing a response to the fast needs. Also, must be flexible and efficient at all levels technology required, until the procedure for delivery of final product in programmed destination can satisfy the need of the market. This type of response requires integration between the properties of materials and their functionality through the systems of production. These are managed and monitored by technological systems of communication and information with installed capacities in cognitive domain. This will establish a direct link with the human operator by means of intelligent interfaces facilitators that uses technologies developed in a micrometric scale with the use of sensors, actuators and systems integrated technology that will allow a level of operability since size small to the nano-scale. This will also allow real time support of the organization and management of the production through distribution, control and monitoring of all the information through a productive network decentralized (Bessey et al., 2009).

A decentralized production through the integration capacity of technologies and new productive systems enable the whole structure of the business model may become socially sustainable to improve in a general manner the conditions of life of a whole society, resulting in a positive cost-benefit analysis for all the interested parties.

6. The benefits from different perspectives

The new Industrial Era presents itself in the near future, as technological development that will change irreversibly the sector of industrial competitiveness. This sector has remained up to the present day with a competitiveness fundamentally based on production capacity and protection of stocks of value added in order to be able to deliver the satisfaction of the demand side of the market. Cycles of life of products present in the market are increasingly short due to technological accelerated development. The management capacity and effective control of flows logistics and production will determine the degree of competitiveness of the company in the new reality in which will be conditioned by decreasing product functionality which arises when is in use. The problem is users and consumers tend to value their own functionality and not the product itself (Yoshikawa, 2008). Whereas in these terms, it may be possible to measure the potential value of a product by its full functionality in service, which will directly influence the competitiveness of the management of the economic efficiency of enterprises to measure the relationship of costs relating to the use of its resources together with other variables such as the inefficiency of processes. With the value of the products generated in the satisfaction of the market will create conditions of competitiveness directed to a reduction of this same added value and the profitability of capital invested (Westkämper, 2009).

The companies that will accompany this industrial reorganization will have more benefits in comparison with the today's companies. The continuous improvements of productive systems and the introduction of innovative technologies will allow a more efficient management of the time through reductions in operations and times waiting in production. This brings the consequent reduction of time to market entry for new products or services. Also, will have the ability to stay in a proper level of efficiency by presenting a consistency in the quality of their products produced, involving the client as an indicator of its own level of performance. The exploitation of emerging markets in a differentiated manner or even create new business models will allow maintenance of leadership integrating the operational process with the other functional areas managing to remain in an industrial market through a sustained growth, building a reputation for reliability in the market near of the competitors. This can be achieved through the incorporation and integration of added value innovations through base corporate strategies.

This all achieved through the union between the technology strategy with the strategy of satisfaction of the requirements of the needs of consumers or customers in focus.

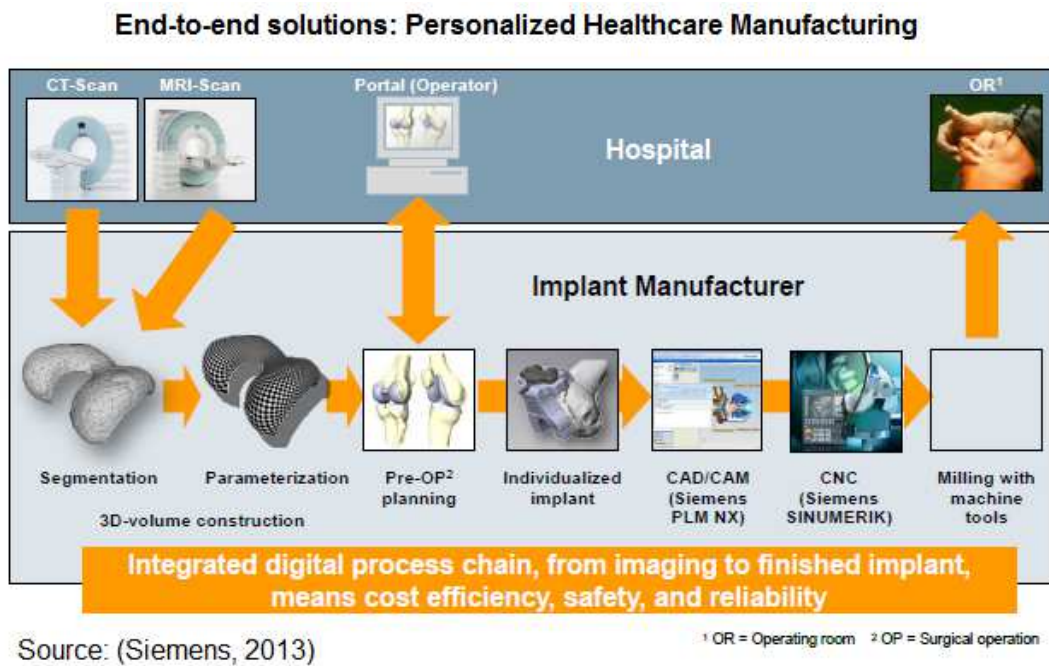

Figure 24. End to End solutions in all fields (source: Siemens, 2013).

The introduction of Cyber-Physical Systems in productive chains makes possible the direct interaction with the customer and surrounding environment. This brings benefits to both parties since the production may managing this way fully satisfy the real needs of the market, with the consequent economic benefits for both parties.

Must be referenced the need of more analyses to support to the industry through state programs. This question is raised because it is not consensual at all specialists in economics because in Economic Theory in the broad sense, suggests that this kind of need for intervention at this level in the private sector should be justified by failure on the viability of the market where the private interest differs from the interests of the society. For this reason, this should be strictly regulated before being stimulated.

6.1. Productivity and the Internet of Things

The rapid growth of the communication capacity of the system machine-to-machine is an indicator of the future of the Internet of Things as a present reality in industrial productivity of the future (GSMA, 2011). The identification of the elements most varied through codes that can represent and also interconnect groups and individual entities in real-time, using sensors to perceive the surrounding environment variables with actuators controlled by other autonomous equipment allows an increase in productivity (VTT, 2013). These represent the union between these three worlds integrated. Requires also that all

those present in the value chain, from suppliers of services to all the other that are present, must have the technical capability and technological to collaborate with the network.

Productivity

The concept of productivity does not reflect a common opinion among the whole scientific community but to the topic discussed in this thesis, is used the definition of the OECD productivity. OECD claims productivity as the ratio between a measured volume of outputs and entries. This becomes understandable that sensitivity of productivity directly depends on the purpose of the measurement, quantity and reliability of the data available even when some of these are impossible to obtain in a quantitative measurement. The companies attempt to capture all the opportunities of capitalization that this New Era can bring, especially to reduce the time required for decision making. This can be achieved through the use of computer programs based on real-time information for decision making, operational control, process optimization, evaluation and optimized management of resources capable of processing all the information independently and global.

This whole interconnection possible will increase industrial productivity through the implementation of a capacity for flexibility of production. To become relevant in real-time, all the information necessary for operation productive between the most diverse sectors and production volumes must be available. The production locals may themselves be relocated geographically within a strategic global plan. These releases the need from physical location of equipment to support the production line, but manage to capture the entire value added necessary. This also allows own client can be involved in the process of creation and development of desired product in order to obtain a personalized response for productive requirements.

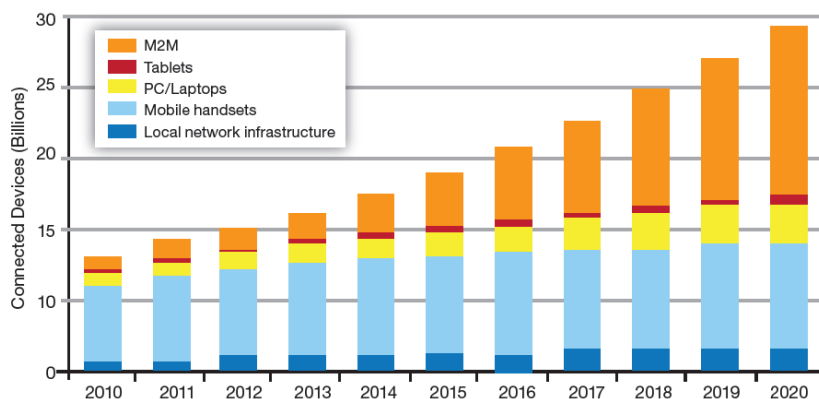

Figure 25. Growth of M2M communications (source: GSMA, 2011).

All these variables will allow an improvement in industrial performance, through a more efficient production already that can mention that the productivity improves when it is possible to eliminate waste or operational capabilities not vital to production (VTT, 2013).

Maintenance

Another way to increase the level of productivity is reduce or eliminate the non scheduled production stops, through maintenance more effective. This ubiquitously presence can interact in a dynamic way and omnipresent with the whole productive system through the use of sensors that allow to monitor the state of operation during the process. Also, allow to share information with partnerships of maintenance with capacity of physical distance acting that can act directly on the issue through a network of shared information scheduling predictive and preventative maintenance actions. This will allow the equipment to be able to identify them for intervention as well as notify errors in case of intervention need, making them less dependent on the base infrastructure. All these sensors implemented will empower automation systems react flexibly and rapidly to changes of programmed conditions of production. Through warnings and alerts in the most varied functional fields, these will help avoid future costs and make more effective decisions. Currently, it is still needed a technological development at the level of the sensors so that these can become autonomous in the level of energy storage and ensuring security the data transmitted.

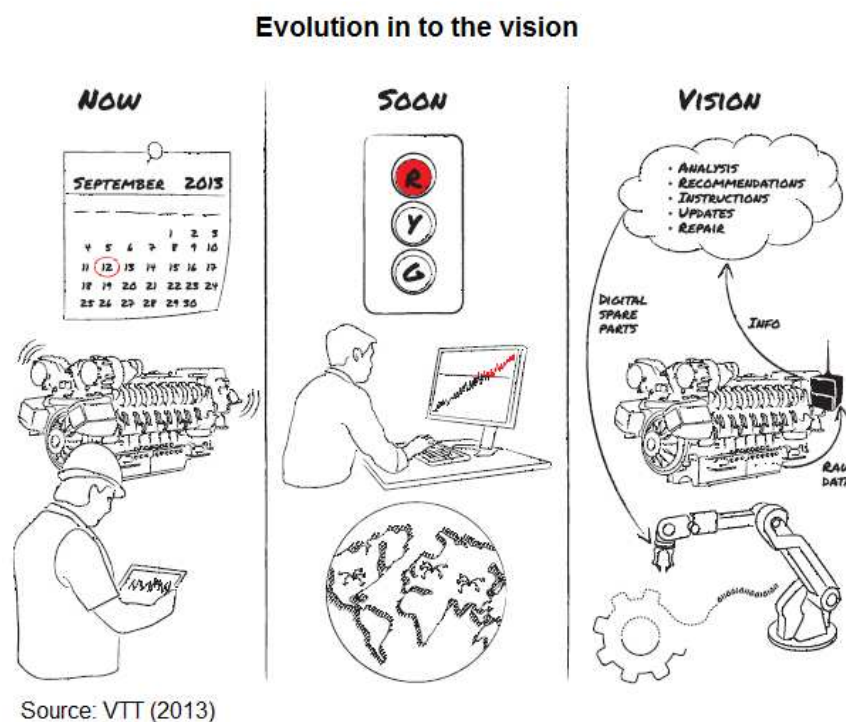
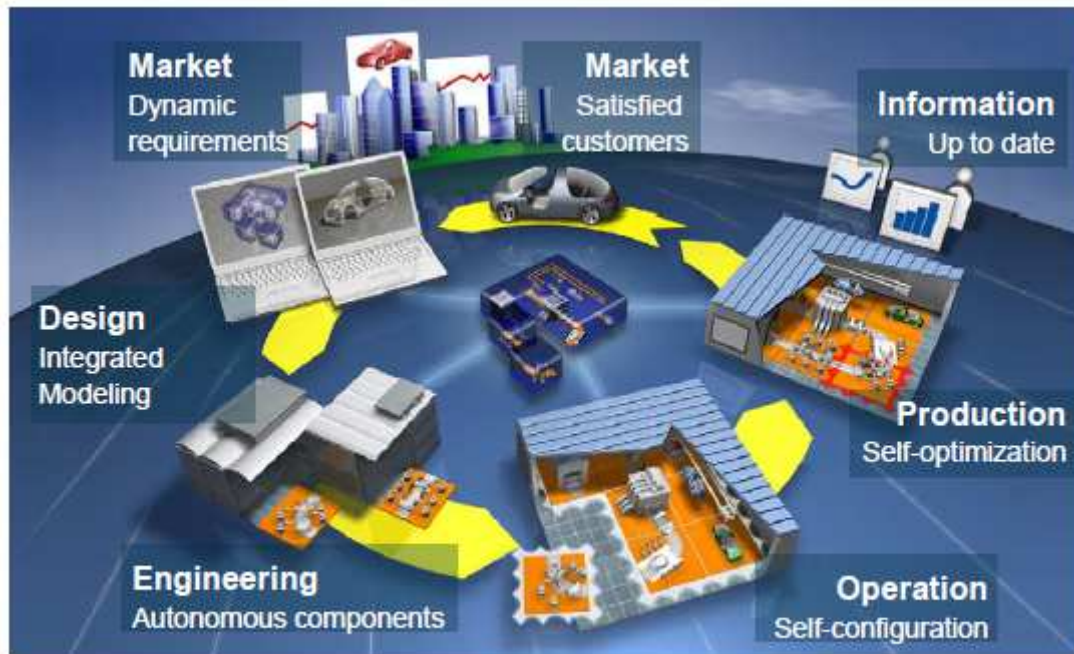

Figure 26. The evolution of the interaction between the elements (source: VTT, 2013).



Source: (Siemens, 2013)

Figure 27. Increase of productivity to the most varied levels (Siemens, 2013).

Product

At the level of the product itself, this will be integrated with a dynamic storage of digital data. This gives the ability to communicate with the environment in the improvement of the productivity. The product passes to be itself a vehicle of information throughout the supply chain and of its life cycle. This way has an active role in its environment through self-monitoring in order to become more efficient in its value added.

The potential capabilities in the Machine-to-Machine communication will allow a simplification of manual actions and automatic actions during production. These allow to continually updating information, tracking the status of the process using the information provided by the environment to trigger actions in real time. These capabilities increment a better and more dynamic process capacity. This is possible if ensuring that such equipment can ensure cycles of use relatively long through a use robust and durable with minimum need for use of hardware updates, but high capability for software updates. This allows integrated solutions, but brings implications at the level of coverage of the networks of ICT and upgrading of their own communication equipment (GSMA 2012b).

6.2. Business opportunities

Smart equipment systems can allow integration of information at several levels and can stimulate applications in varied business models. This will open opportunities for the creation of new business (Bohn et al. 2005). Currently, its potential has not yet been completely understood to be leveraged (Bucherer et al., 2011).

A business model is represented as a company expected to generate and obtain economic gains. This should be done through a structure representing the value-added chain interaction with the industry where the demand must maximize the pursuit of the economic profit through the introduction and presentation of a new capacity. At the same time, it should minimize company exposure to the risk of capital invested by focusing on obtaining the optimization of realization of economic value for its shareholders and all key stakeholders, as a competitive response to the satisfaction of the needs of the market (Porter, 1979). The industrial companies may invest strategically in its capacity to create a high adding value through a Knowledge based in Competitive Sustainable Manufacturing as a goal to achieve. This should empower them to resist the threat of the increasingly competitive market and maintain their sustainability in global markets, through the creation and development of new business models, products and services of high added value (Jovane et al., 2009). These are capable of withstanding the economic, social and environmental challenges at the same time that stimulates the efficiency and creativity of its own employees and meets the market differently and in order self sustained (Willians, 2009).



Source: (VTT, 2013)

Figure 28. Manufacturing scenario involving different stakeholders in the supply chain (source: VTT, 2013).

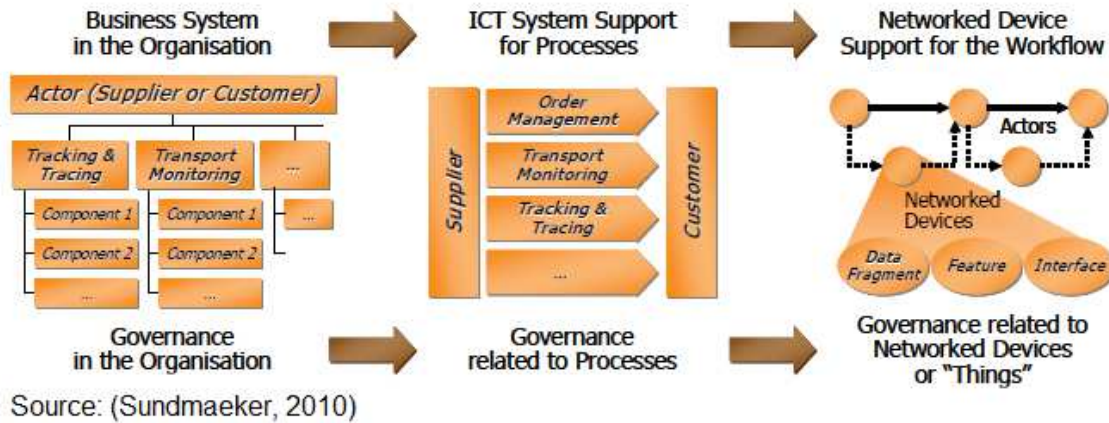

Figure 29. The usage of Networked Devices Enabled Intelligence (source: Sundmaeker, 2010).

These new strategies assumed, obligate to a whole internal reorganization in which the entered value by supply chain ceases to be merely a process of internal management focused on cost reduction, but start to be an external management where the flexibility and consequent management of risk assumed will have a fundamental role. With the looming future of generalization of technology, are created the conditions for the introduction of new business models and reorganization of existents mainly of those who suffer stagnation. New strategic alliances through the operability in new technological environments of complex systems makes possible the development maintenance of the capacity the creation of added value although exist constraints on actuation for the creation of these new models will continue to exist. This happens because they are subjects to public debate in order to justify its nature and conditions of satisfaction of the needs of the market.

Value Networks: Business Innovation

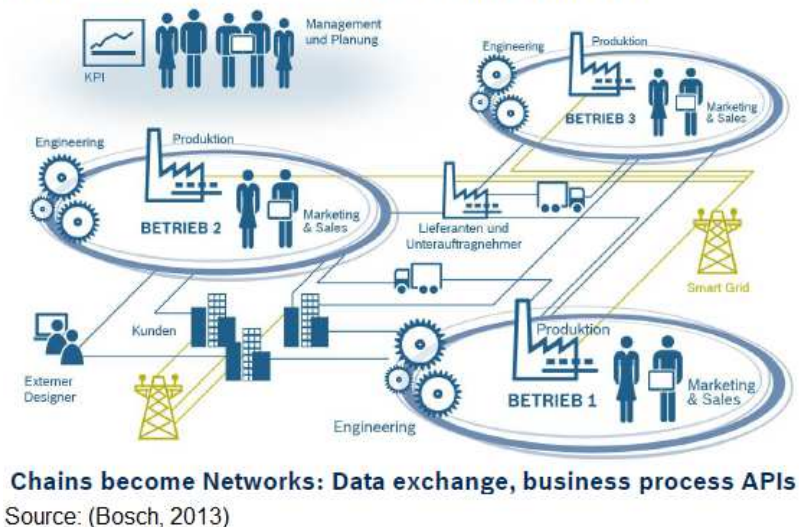

Figure 30. Value networks in business innovation (Bosch, 2013).

Design and develop new business models in this environment makes obligatory having the ability to exchange information between all network elements in presence and between all the stakeholders in order to be able to leverage in it full economic potential (Bucherer et al. 2010). This have vital importance in manufacture, support and value creation, where the manufacturers want benefiting from the possibility to trace their products and get support to gathering the data necessary to allow the creation of added value in the entire value chain and the customer (Mejtoft, 2011). These allow activities that involve financial procedures or trade between companies and other entities at the level of production, logistics, services, intermediaries and even governmental authorities will be more rapid and facilitated.

6.3 Jobs creation

In the chain of value creation of a model of business in society, whenever a company carries out purchases of goods or services start an action. This action has just generating an indirect impact on employment creation, resulting in a multiplier effect, in the most varied sectors due to the need for interaction between all the chains functional to the satisfaction of the need as supplier (Immelt, 2011). This effect may have as a consequence the return of millions of unemployed back to work activity. With the decentralization of production, the factories are becoming increasingly technologically advanced. This will allow a greater breadth productive due to access technological knowledge allowed by communication and information networks by fostering the indirect employment. This will have as a consequence an increment of the multiplier effect on employment creation (Milken Institute, 2013).

This can be understandable since for example, a number crescent use of computers in a factory creates the need for a support of services at the level of information technologies.

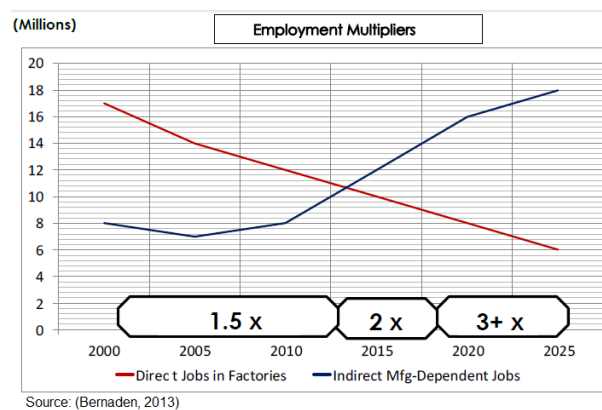

Figure 31. Employment Multiplier Effect (source: Bernaden, 2013).

6.4. Risks and approaches to manage them

The creation of added value always involves risks. It's not possible eliminate risks in financial investments which may put into question the economic sustainability of an irreversible manner in many companies. Only through new forms of constructive and cooperative interaction between society, politics and industry will be able to successfully implement a national common strategy in Germany. The integration of a digital and physical world with autonomy and control in decentralized way will occur with the merger of the systems. Although anticipate a huge potential this synergy, also comes with enormous risks, mainly at the level of security of information technologies through necessity in sharing and transmission of data. In logistics dependence, in industrial nations such as Germany with few material resources in raw materials, can lead to a loss of value added generated internally to suffer from price increase of some materials vital to supply its domestic industry. This will be an increasingly digital world vulnerable and magnified by high complexity of networked systems, by virtualization of some business processes and the automation of production processes especially in sensitive areas such as the energy resources, transport, communications, and raw materials for industry. The independence of systems becomes increasingly more expensive to maintain and can affect the competitiveness of the nation in the global markets.

Increased Complexity

The increase expected of corporate growth and economic enterprises through the mobilization in this national common path introduces a factor to be taken into account in the management of risk. The increased complexity of the systems. This can become very difficult for monitoring of the process due to the lack of organizational capacity, flexibility and adaptation of some organizations. This happens because it will continue to be the human being, the element responsible for building the bridge between the current world labor and the expected future. This constant updating need will be so omnipresent that uncertainty will be a constant variable in industrial environment being managed, both at a competitive level as in markets.

Volatile Markets

Studying possible market opportunities and risks allow a vital and consequent improvement in the management of risk. These actions increase level of predictability and

can predict and prevent rapid changes, violent and radical as those that Germany has suffered in recent years due to the meager stability of international markets increasingly dynamic. The industry is avoiding the classical competition in international markets. Industrial companies are no longer to be mere producers of economical scale competitive products, but pass to be suppliers of integrated solutions, where the line between the services and products cease to exist avoiding saturated markets. Differentiation is located in maintaining an emotional connection with the end customer in order to achieve a long-term customer loyalty since the potential for mass production for the mature markets is already saturated. One of the risks of this investment lies in the fact that a product or service oriented to the customer requires knowledge. The knowledge needs financial investment. The conventional market is no longer sufficient to sustain national society sustainability in long-term. The industries have to develop a capacity of mass customization to meet individually each consumer.

Reorganization of employment system

At the level of the reorganization of the employment system with vision to achieve high labor flexibility it becomes a necessary condition creating a network through a virtual enterprise. This must allow integration of customers as co-producers in production system support. The production system will be managed in an increased risk environment of relational flexible structures and goals. This must be done in horizontal system of hierarchies in a temporary time frame. The problems resulting from this type of organization are difficult to calculate. Some national forecasts allow previewing the decline the labor force in the next few years with technical skills especially in the area of Mathematics, engineering, science and technology. This can put into question the technical full capacity of innovation in the technology German industry. There is also the risk of addressing need for relocation of business structural units in other countries. This necessity has consequence the risking losing this domestic added value. This fact will decrease the industrial domestic capacity maintenance as well as the competitiveness with countries where there is not the decrease of this factor. The consequence results in an increase of industrial costs and even the labor market costs.

The strategy applied to a development of Cyber-Physical Systems with support in Information and Communication Technologies, allows reducing the impact of this reduction of technical ability in the workplace.

Security

The accesses increasingly facilitated by information and communication technologies allow the possibility to suffer acts of cyber terrorism or technical failure at critical points. This can even induce a cascade effect due to the integration of systems needed, decreasing the confidence in systems in use. The security in infrastructure can enable viability of a society and it represents the society itself. In Internet of Things, the risk is latent in all the institutions, in the business processes, industrial complexes and transport systems based on information technologies. Represents a universe fragile, but became common in society with the evolution of technology. With this potential threat, should be increased the levels of development and updating of security systems. These security systems should be standardized it voluntarily by development entities or by ensured state regulation. This common standardization ensures a transparent and correct transmission of data between the communication terminals. Even though it might represent an added cost can be amortized through security and reliability by the allowed system. The value of knowledge is an asset that should be safeguarded because it is one of keys critical success factors.

Communication with all interested parts

Risk management requires a global view of all the factors in consideration. These are conditioned by insecurity in most diverse components of society. One of the reasons seems to be the often inadequate communication between prescribers, political, scientific community with the general public. This often results in developed technologies never used, despite the inherent costs technological development for the whole society. The European tradition of management in a general way is more susceptible to adopt an initial rejection of an innovative idea. When accepts requires a long and complicated process of decision before accepting its potential contribution. This contributes in some way to not stimulate a rapid implementation of projects in good time. This becomes critical due to the globalization of the media and logistics.

Resources

The lack of natural resources in raw materials for industry use represents a risk to the maintenance of German industrial capacity. It becomes critical due to potential formations of cartels or economic games played by countries with aggressive external policies of protection of the market. These actions will raise the internal costs due to the need of

import of raw materials. The research, development and application of substitute technological raw materials and systems can mitigate this risk.

Another resource risk is already included in the Strategy 2020. It is the investment in renewable energy and expansion of the national energy system. This must be managed and maintained in a more efficient manner (acatech, 2013). Emerging countries are incrementing its own industrial capacity. The power consumption in world will also increase. This will cause prices to increase by a percentage higher than inflation and raising the level of total costs. The industry must anticipate and manage this risk through a policy of efficiency in the management and monitoring of its own energy consumption. This means having equipment updated and using renewable energy. These allow reducing dependence on external energy and raw materials. This can be achieved with focusing on the reduction of non essential materials, with recycling and using processes in production methods that require less expenditure of energy.

The German industry has a mature industrial culture. It can be competitive and modern in many areas. With a large network at the level of logistics, suppliers, manufacturers, diversified services and a high-level of skilled workers can maintain a high degree of technological knowledge and industrial in the future. These allow continuing the leadership in global industrials sectors.

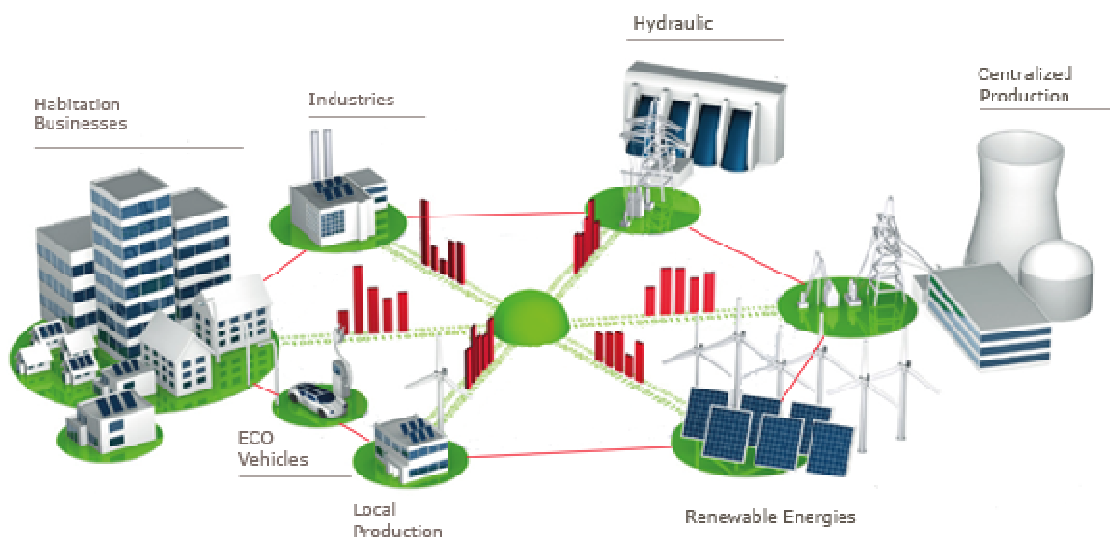

Figure 32. Energy management and risks mitigation (source: EPFL, 2013).

7. Applications of the concept

Industrial factories are in a general form, organized with emphasis in a hierarchical structure since the administrative area until the technique area. This poses some difficulties of management with the increasing complexity of future systems. These require complex and saturated management systems since productive systems, maintenance or even the business models presents. This will entail a saturation of data without value to be managed in a general way. These systems are multidisciplinary and have in their majority limited interoperability.

The future brings with it challenges in the industrial area on the organizational management level. There is a need for an innovative integration into full of productive systems, processes and products to perform with available tools in order to synchronize the product, process and factory life cycles (Wiendahl et al., 2007).

7.1. Advanced Manufacturing

It can be expressed Advanced Manufacturing Engineering, as an improvement in the creation of materials, production of products and use of processes through the use of engineering and information technologies. This using methods and tools of high accuracy through innovative organizational models, able to have the flexibility and speed in customizing products in small or large scale in an optimizing the use of resources (IDA, 2012). This is a concept broad and multifaceted, with direct and indirect implications in the whole universe industrial and social.



Figure 33. Dynamic relations with Advanced Manufacturing Engineering (source: Westkämper, 2006).

This concept is not a static entity. On the contrary, the industrial innovations of today are the classical processes in the future. The pervasive role of information in the models of production will allow an assertive use of modeling and simulation in the manufacturing process. This information's can accelerating the innovation phase in the supply chain management and adapt for the reaction in real-time from the changes of customers requirements or productive setbacks. This can fostering a more sustained and integrated production among all levels of the process already that the utilization of information allows to accelerate the productivity of a general form as maintain a level of quality able to efficiently control the entire process (Lorio, 2011). This has influence at several levels in a factory, despite what typically describes the existing paradigms concerning the amendment of the production capacity of the industrial systems such as flexibility, reconfigurability, transformability and the agility (Najam Sethi, 1990; Gould 1997; Mehrabi, 2000; Jovane, 2003; Wiendahl et al. , 2007).

With the deployment of a true flexibility by means of productive equipment capable of adapting to new materials and designs, it will make the business models become more robust against supply chain disruption (Ehmann, 2011). At the same time, will have the ability to predict future changes through a sustained learning (Iorio, 2011). This will help decision-makers and engineers in the reduction of some variables in their work while maintaining a satisfactory degree of sustainability in use non-polluting processes. This way, it's possible to optimize the management of resource use and providing a safe and healthy environment for all the interested parties (ITA, 2011).

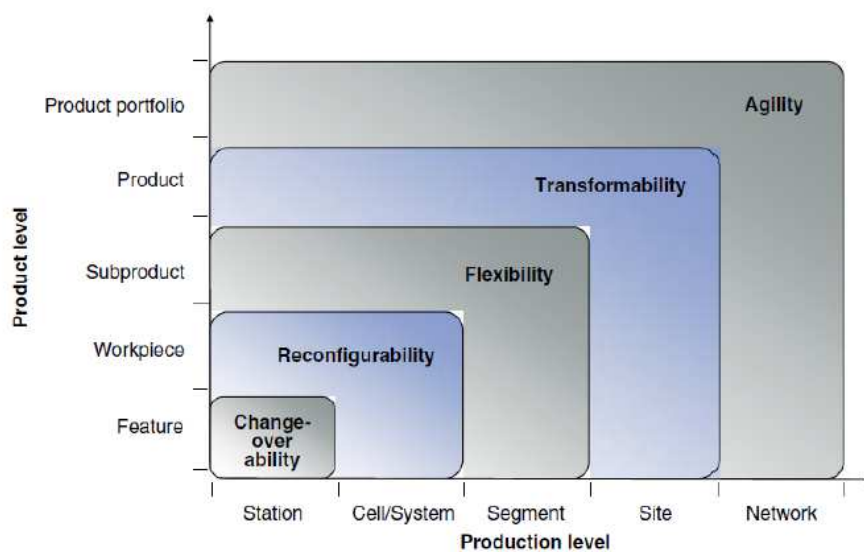

Source: Wiendahl et al. (2007).

Figure 34. Schematic of alteration of production capacity (Wiendahl et al., 2007).

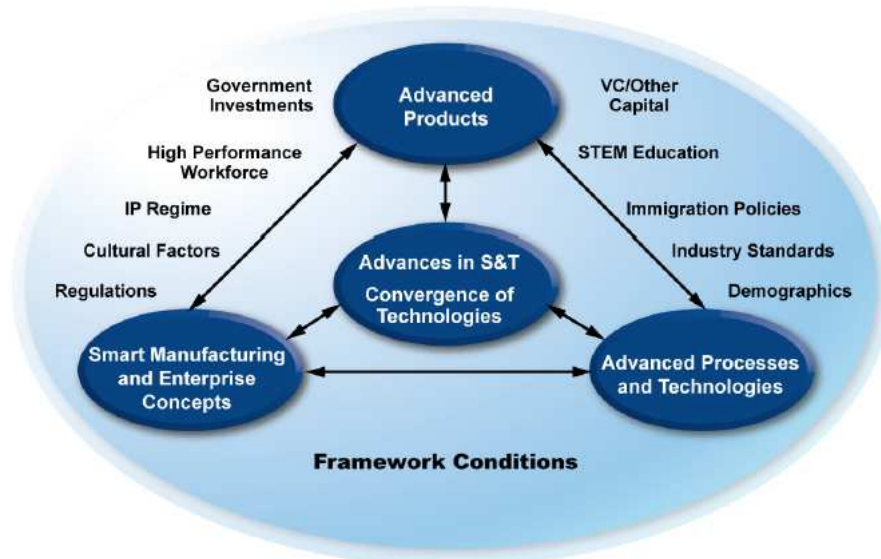

Source: (IDA, 2012)

Figure 35. Framework conditions for integration of the process (source IDA, 2012).

This type of advanced production begins with the modeling and simulation in order to minimize the time required from the design until the delivery of the product. The technologies of information and communication allow expedite the supply chain to respond to fluctuations in demand through an optimized production. This can be possible because uses intelligent materials with new and innovative internal structures (Mathaudhu, 2011).

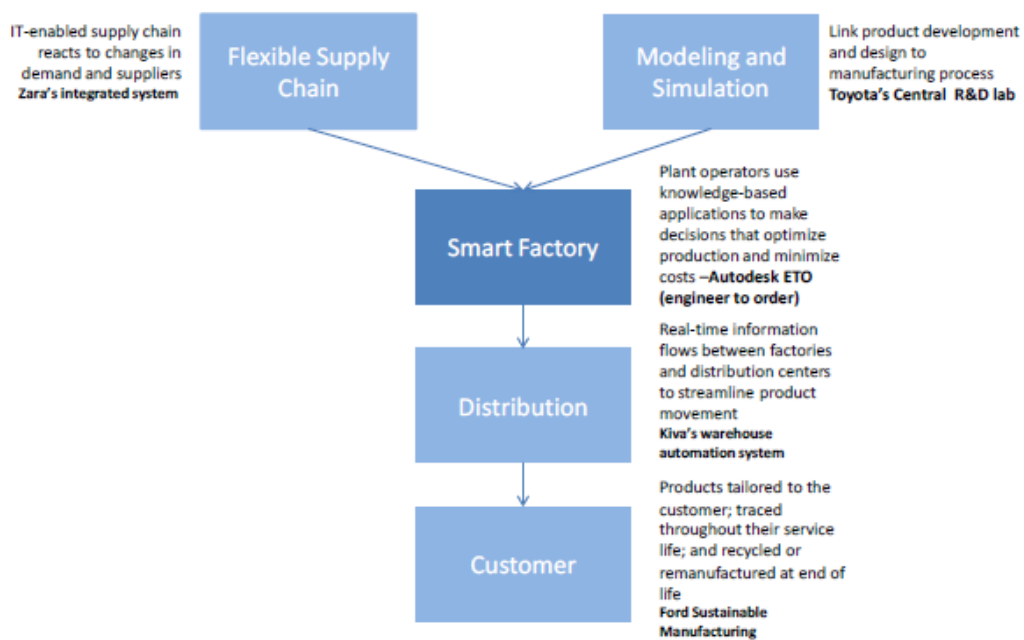

Source: Adapted from SMLC (2011).

Figure 36 Advanced manufacturing enterprise concepts (source: Adapted from SMLC, 2011).

The Additive Manufacture Systems in production will reduce the waste resulting from the removal of the material in classical production systems as well the necessary amount of stock of raw materials for components needed. The products will be produced just in real time with the multiple custom products with all the requirements of demand.

7.2. Smart Plants

To predict the requirements to organize the factories of the future it is necessary to understand how to operate the factories of today. In a general way, operate at the level of process control using cycles of control to maintain key variables within defined limits. The disturbances normally expected are managed on the level of the process through a hierarchy based on tools of decision making models designed to maximize the profit generated through the creation of value of its activities by planning actions and protocol reactions through a set of alarms (Bagajewicz, 2009).

In the future, the monitoring of the factories will be essentially based on the analysis of data transmitted by sensors in an optimized way in economic considerations at various levels and areas. This will be done in order to balance the maximum profit through an optimized operability with the need to comply with the legal requirements and interests of all the parties concerned. All possible through a pro-activeness automated and in real-time using the infrastructure and assets in optimized and sustained way (Christofides et al. , 2007). In this way will be possible to each asset to contribute directly in implementing its own basic function in providing feedback information with a predictive knowledge to management decision-making system. This will maximize the performance under any type of productive or requested environment.

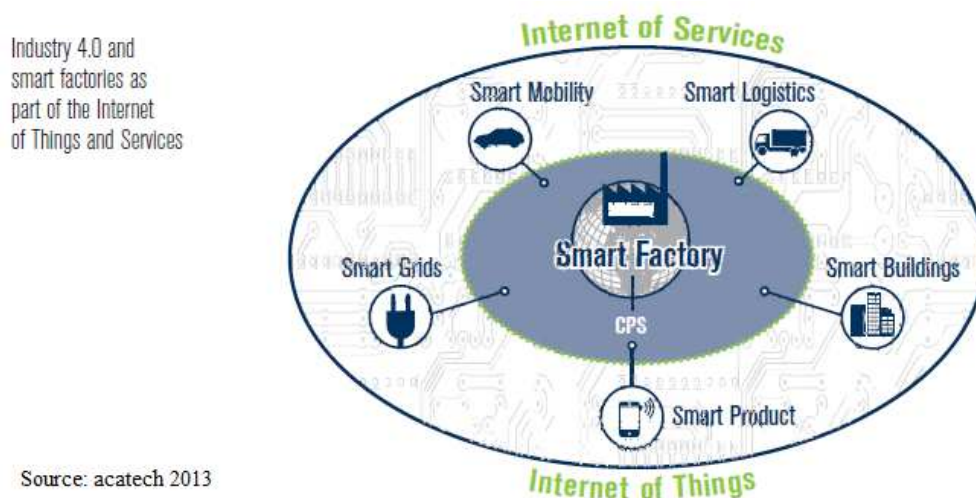
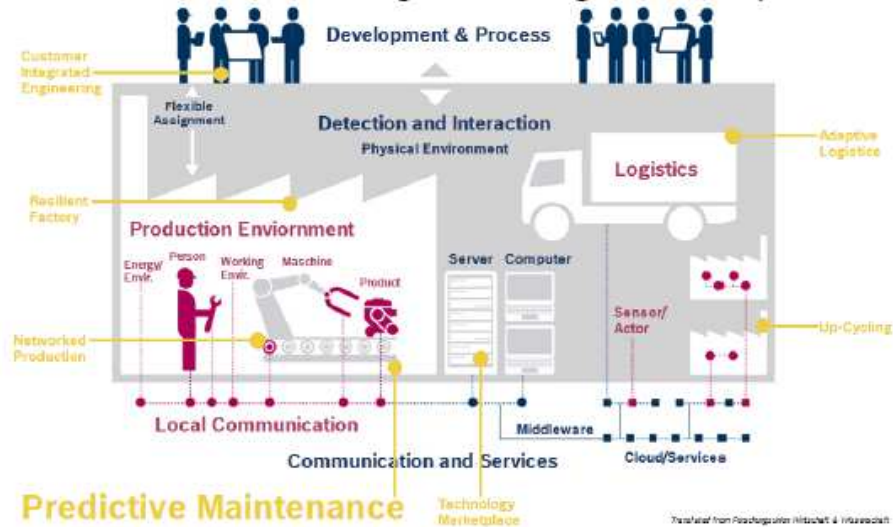

Figure 37. Smart Factory connectivity in Industrie 4.0 (source: acatech, 2013).

Smart Factory

→ **New business models** through the convergence of IT & production



Source: (Bosch, 2013)

Figure 38. Smart Factory global view (source: Bosch, 2013).

Currently, the development of methodologies to process control must manage non linearity's, predictive uncertainties among other restrictions at the level of optimization of the industrial organization. Already is possible beginning to allow a reaction in some automated systems. Future systems will be capable of monitoring the process in an autonomous manner through emissions of actions and intelligent reactions to overcome problems adapting to new situations. This will be done within the time useful and sustainable pro-actively interacting with humans through cybernetic tools (Bagajewicz, 2009). The infrastructure can be managed independently in operational decision-making with the less human intervention. Will be gathered and analyzed all information in order to predict potential problems and acting in accordance to effective and efficient form in the use of their resources. This will maximize all the possible added value of production. The greater part of these activities requires consistent and accurate data by which the sensitivity of the same will be conditioned by the quality of the instrumentation and sensors used. These are elements that oblige always to an outlet of relative decision in the company due policy of acquisition costs. Each information is obtained from each sensor represents an economic cost that must necessarily be less than the added economic value obtained by its use (Bagajewicz, 2000). Without the economic considerations, it is not possible an implement efficient smart factory.

These will allow a better and more flexible global reconfiguration and integration of mobile devices in the core system for human aid in relation to control and monitoring activities. These are capable of producing a more rapid and effective decision-making. A research case study is presented in appendix B.

7.3. Digital Virtual Plant

A Digital Virtual Plant can be described as a factory to be operating as a whole in an integrated simulation environment, through an advanced planning, a decision-making support and capability of validation (Jain, 2001).

The development of systems and production processes, as well as its products resulting from, known as Co-evolution, obligates companies integrate the different methodologies in action. This will allow digital tools available can become effective and efficient since the rapid changes, often unpredictable and extremely complex, are not yet properly addressed by existing today solutions (Tolio, 2013). Virtual organization can be described as a flexible network of independent interconnected entities by means of information technologies to share skills, knowledge and access between themselves in non-traditional forms (Dumitrache, 2013). This problem exists in manufacturers of industrial equipment. These have to provide the industry with a product capable of satisfying their productive needs, mainly at the level of the design, deployment flexibility and reconfigurability.

A factory integrated must have as its main objective being a workplace where is possible to perform a multiplicity of analyzes through integrated tools in different disciplines of knowledge. These interacting with each other through a common path in a consistent manner through the same type of system used by multiple elements involved in industrial infrastructure.

The new complexity introduced by new systems of future production, reveals the need to become easier using the current digital tools. These digital tools per tradition, were designed to intervene in specific tasks, with its own templates and not are capable of integrate in open sources. Must be needed creating a common platform for integrated operational systems for all models to be used in industry. These allow a better collaboration.

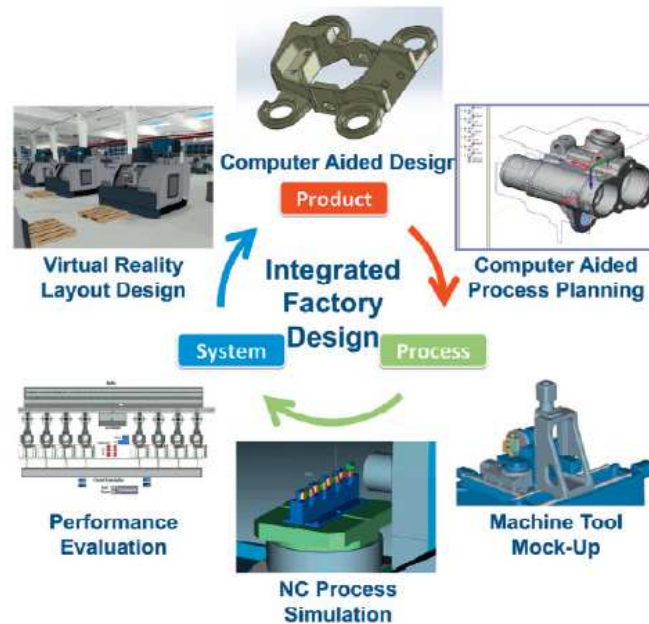

Source: (Tolio, 2013)

Figure 39. A conceptual Framework of Integrated Factory Design (source: Tolio, 2013).

These digital tools must manage the entire type of information related to the trade-related aspects on design, operation, phase, processes and resources in a coherent and updated manner. This must be done by integrating the knowledge with the information available from various sources and origins with technology at various levels of detail. The knowledge can slow down the operating cost at the same time that maintains a virtual representation synchronized with the operation in real-time (Tolio, 2013). This type of tool lets advantage for the models of decision making without the need for investment in infrastructure costly and little flexible. Also, have the ability to exchange data and knowledge for a speedy, shared and joint decision between all the interested parties.

The paradigm present for this type of facility is the ability to draw up a response capable of solving some essential factors such as the reduction of production time and waste of raw materials. This can be achieved through the virtual design of new products at the same time that develops storage of digital knowledge susceptible of being consulted and used by those involved in the process of production. This way is possible improving the efficiency and safety of all parties involved due to the possibility of using a virtual education in productive systems in an interaction network between different disciplines (Saeco, 2013).

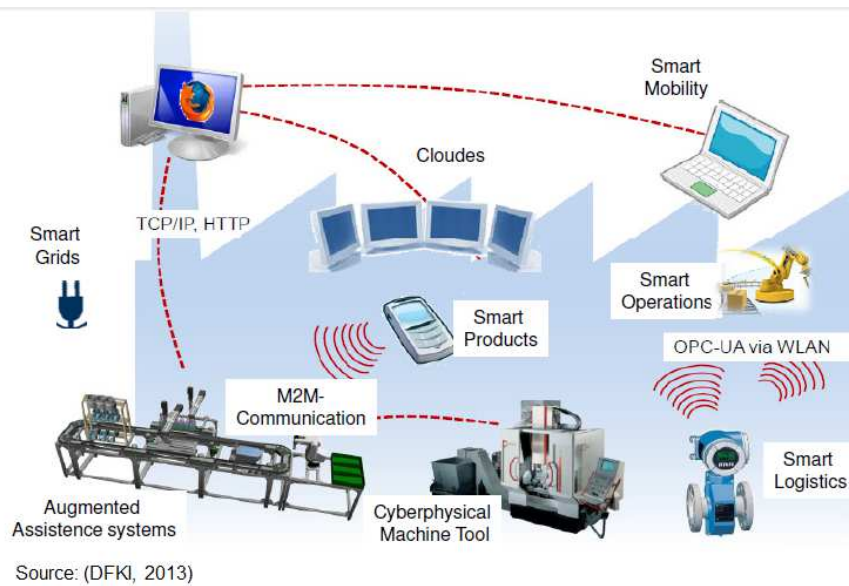

Figure 40. Cyber Physical Production System (source: DFKI, 2013).

The complexity of these types of problems requires an effective response in the creation of support tools and global support capable of integrating all the phases of the life cycle of a manufacturing plant. By means of software tools for managing the life cycle of the product, known as Product Life Management, becomes capable manage planning, the manufacturing design and remaining stages. Until this moment, are still ineffective functionally at this level in nowadays Knowledge.

The elaboration of a generic frame basis must promote the reduction of costs and times for an optimized production. At the same time should allowed, an improvement of the performance of the management, monitoring and reconfiguration of existing facilities and supporting the simulation of complex behavior and dynamic in its entire life cycle industrial.



Source: (Siemens, 2013)

Figure 41. Digital software to assist and support the decision makers (source: Siemens, 2013).

7.4. Smart Manufacturing

The Smart Manufacturing can be defined as the application and use of advanced intelligent systems in rapid production of new products in a process optimization in real-time and the supply chain, through a dynamic response to the demand by the market (SMLC, 2011). This way is interconnected all aspects of production joining the ability of industrial automation with the capacity of information technology. This increment the optimization and efficiency in productivity throughout the entire chain of value creation with the consequent flexibility and effective management of resources (Bernaden, 2013).

The benefits resulting from this type of production can be identified as the reduction of the time for entry into the market of the products and the ability to reach markets differentiated by providing a global capacity of competitiveness. This allows an advantage of integrated management of resources at the same time that allows the implementation of a custom response in order to satisfy the needs of the consumer.

This type of manufacturing allows the execution of transactions in products per batch with only some inputs of raw materials and ongoing operations of production or assembly of discrete operations through a large number of components.

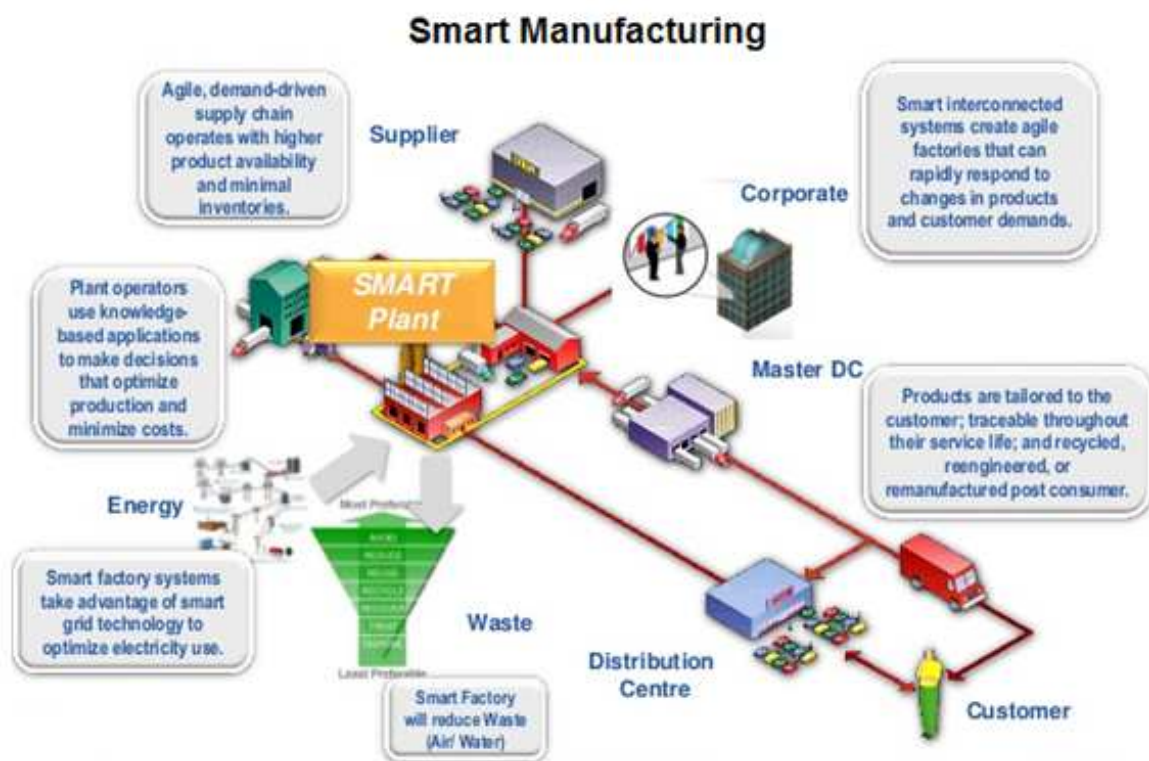

Source: (Mehara, 2013)

Figure 42. Integrated Smart Manufacturing (source: Mehara, 2013).

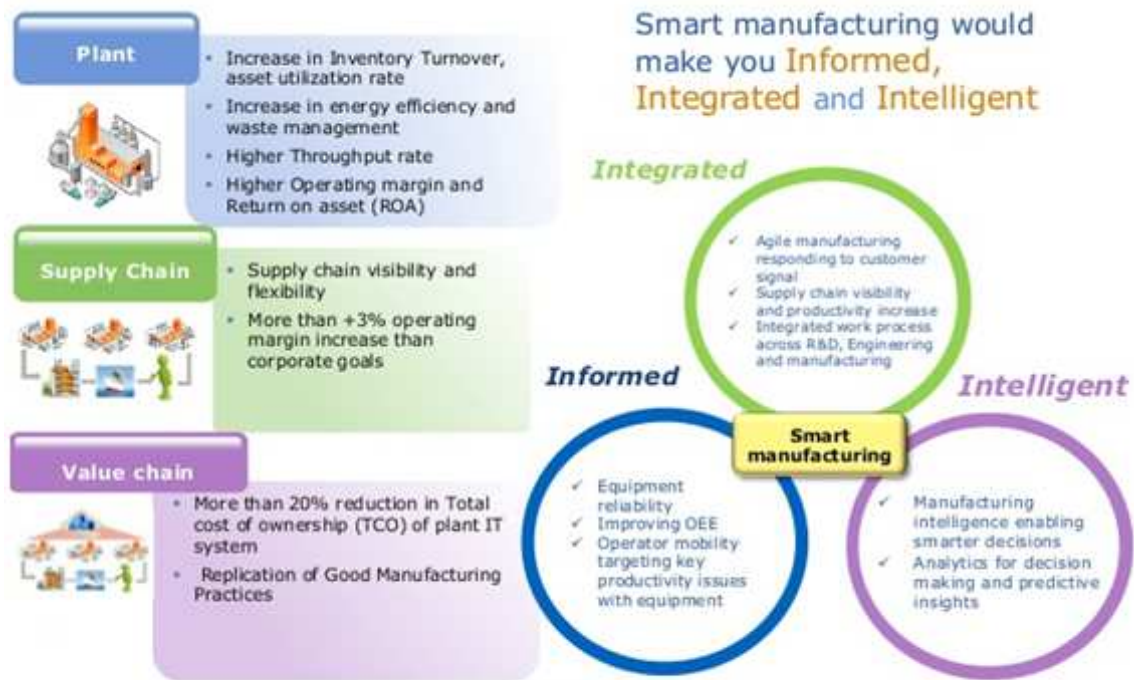

Source: (ARC, 2013)

Figure 43. Smart Manufacturing 3 I's (source: ARC, 2013).

Some prerequisites must be addressed in relation of smart manufacturing. For this to be a reality, it must be necessary to create community industrial platforms for the virtual manufacturing enterprise. These must have a toolbox of software and computing architectures with capacity of manufacturing decision making. Also, must integrate human factors and decision software through user interfaces capable of understanding diverse required skill levels.

Flexible Production: More Customer orientation



... profitable production for lot size 1

Source: (Bosch, 2013)

Figure 44. Smart Manufacturing flexible production (source: Bosch, 2013).

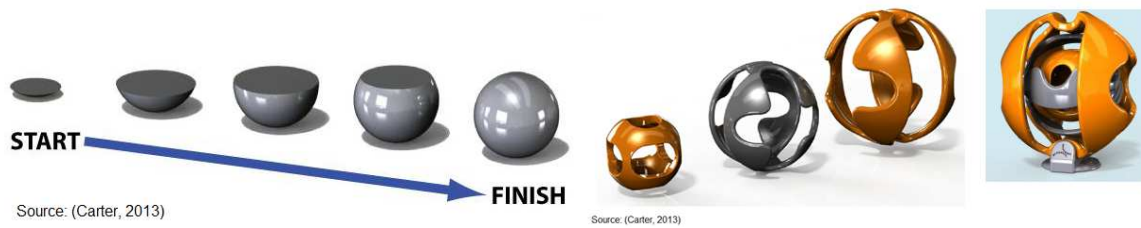

Figure 45. 3D Printing and integrating forms (source: Carter, 2013).

One of the manufacturing processes that integrate all of these concepts is the three dimensional impression. This process enables to reduce the time required between the phase of design and production, through maintenance of quality and reduction of defects in manufacture. This process avoids the use of elaborate mechanisms of manufacture at the same time that allows a reduction of waste generated by reducing material process system. This happen because operates by adding material in layers, resulting in the desired shape. At the same time, enables the implementation of complex forms of structures very difficult to reproduce or even impossible through classic productive systems (Cooper, 2001). This makes possible any form be created. This allows also a customization of the product and satisfaction of manufacturing requirements constrained by demand, representing one of the key factors for the creation of high value-added production.

7.5. Smart Industrial Design

For Smart Manufacturing can reach its full potential productive, the designers must have scientific knowledge as a basis for the development of capable CAD models products and adopt common as a form of direct communication with the production (Bennet, 1992).

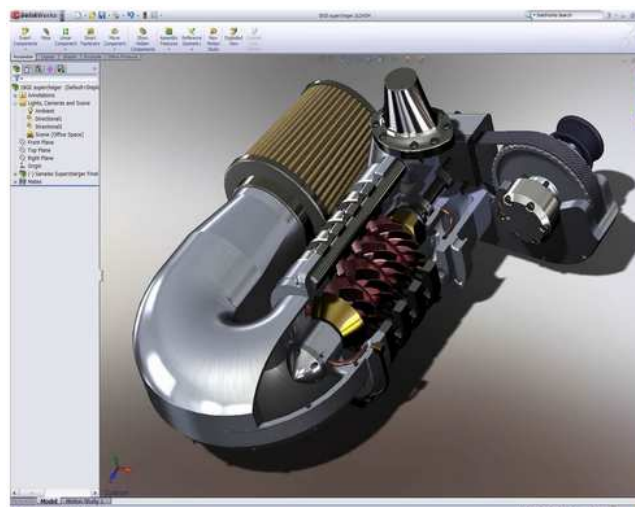
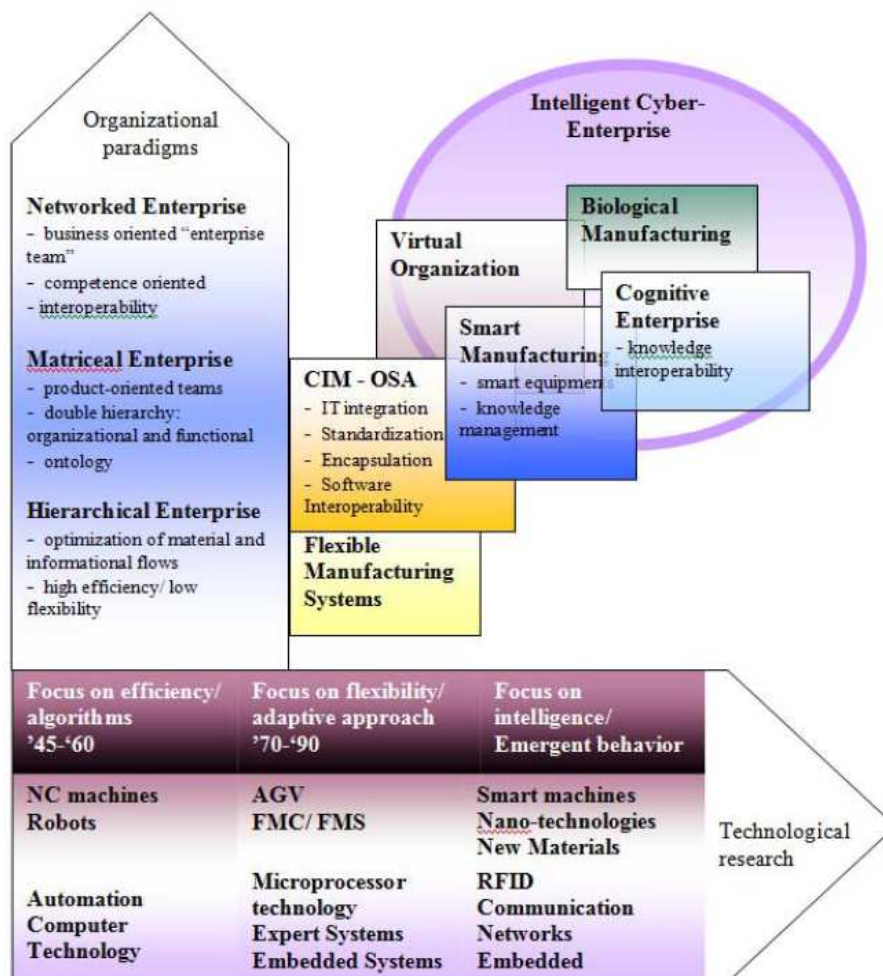

Figure 46. Software to support Smart Industrial Design (source: Dassault Systèmes, 2013).

7.6. Smart Manufacturing Enterprise

Understand the smart manufacturing enterprise has been a challenge to the present day. It is anticipated that these modern factories must be interconnected in a smart way with suppliers, distributors, customers and business systems. These interconnections will be made via information and communication technology in its needs to create an effective key competitive business skill capable to achieve the full Intelligent Cyber-Enterprise.

To optimize performance in all aspects, business management must be closely linked with all supply chain in an agile way. These supports higher product availability and minimal inventories to fast response to changes in products and customers demand. Inside the operational field, plant operators use knowledge based applications to make the decisions necessary to optimize production and minimize cost. This is done in real-time information that flows between production and distribution. This way is possible manufacturing products to the customer in a traceable way throughout their service life if needed (SMLC, 2011).



Source: Dumitrache, (2013)

Figure 47. Smart Manufacturing Enterprise relations approach (source: Dumitrache, 2013).

7.7. Smart Technologies involved

The release of the need to have a physical structure required for an efficient network of communication and transmission of data allows a greater freedom of action in the most diverse industrial contexts. The existing complexity in industrial equipment and layouts obliges to a continuous reorganization of means.

Establish a Wireless Sensor Network becomes a key technology enabling the Internet of Things (Li et al., 2013). These allow connecting sensors and actuators in network through wireless communication, integrating this network into a higher level system through the network gateway. These equipments are generally lightweight, inexpensive, easy to deploy and maintain. These exhibit a functional capacity limited only by resources required for its correct functioning as the available processors and the sources of energy among others (Akyildiz et al., 2002). For that be possible is needed to establish a correct functionality. Becomes necessary the development of architecture and protocols able to allow satisfy the needs especially at the level of communication reliability (Yick et al., 2008). This allows a full development of a Ubiquitous Sensor Networks, where their main functional elements are housed in its Sensor Area Network. Its function is the collection and transmission of information about their surrounding environment. The Wide Area Network gathers the information from sensors as intermediary in communication with external entities or central control.

There are some technologies that allow convert the concept in to reality, by which are present below some of them as example. An analysis could be found in appendix A.

Communication Technologies														
	NFC	RFID	Blue-tooth®	Blue-tooth® LE	ANT	Proprietary (Sub-GHz & 2.4 GHz)	Wi-Fi®	ZigBee®	Z-wave	KNX	Wireless HART	6LoWPAN	WIMAX	2.5-3.5 G
Network	PAN	PAN	PAN	PAN	PAN	LAN	LAN	LAN	LAN	LAN	LAN	LAN	MAN	WAN
Topology	P2P	P2P	Star	Star	P2P, Star, Tree, Mesh	Star, Mesh	Star	Mesh, Star, Tree	Mesh	Mesh, Star, Tree	Mesh, Star	Mesh, Star	Mesh	Mesh
Power	Very Low	Very Low	Low	Very Low	Very Low	Very Low to Low	Low-High	Very Low	Very Low	Very Low	Very Low	Very Low	High	High
Speed	400 Kbs	400 Kbs	700 kbs	1 Mbs	1 Mbs	250 kbs	11-100 Mbs	250 kbs	40 Kbs	1.2 Kbps	250 kbs	250 Kbs	11-100 Mbs	1.8-7.2 Mbs
Range	<10 cm	<3 m	<30 m	5-10 m	1-30 m	10-70 m	4-20 m	10-300 m	30 m	800 m	200 m	800 m (Sub-GHz)	50 km	Cellular network
Application	Pay, get access, share, initiate service, easy setup	Item tracking	Network for data exchange, headset	Health and fitness	Sports and fitness	Point to point connectivity	Internet, multimedia	Sensor networks, building and industrial automation	Residential lighting and automation	Building automation	Industrial sensing networks	Sensor networks, building and industrial automation	Metro area broadband Internet connectivity	Cellular phones and telemetry
Cost Adder	Low	Low	Low	Low	Low	Medium	Medium	Medium	Low	Medium	Medium	Medium	High	High

Source: (Karimi, 2013)

Figure 48. Communication Technologies (source: Karimi, 2013).

For a full development of the concept, it requires that all systems have to be at the same level of development among themselves in the three key variables: integrated Intelligence, infrastructure of communication and interaction. Also, it should be understood that the elements smart are not smart because these have capacity created by preconceived actions by humans. These are smart because they are interconnected among themselves and across all networks in an integrated and autonomous way (Tau, 2010).

As an example, radio wave communications like Near Field Communication, allows communication between devices by means of a physical touch or entering in the zone of proximity (Medaglia, 2011). Radio Frequency IDentification, uses electronic frequency in radio waves electromagnetic field to transfer the data applied by approximation of the reader, in real-time without the need for a physical connection or visual range (Atzori, 2010). These will be some of the support communications technologies allowing the integration of physical elements on the Internet of Things.

Industrial Cyber-Physical Systems will integrate this integrated network of communication. This potential will bring the operational capability required to enable real-time management of all equipment and systems necessary. These allow autonomy, flexibility and ability to rearrange whenever is necessary without the need for direct intervention of a human operator. These also will have ability to communicate among several industrial equipment, vehicles, machinery and collaborative systems through the use of sensors connected to the base network (Booyesen, 2011). These make possible two types of communication: the direct communication directly between physical elements or the communication of the physical element with the structure, being this type of integrated communication the part of the structure of the intelligent management system (Rooyen, 2011). This done with embedded processors, actuators, devices or computers (DYE, 2008).

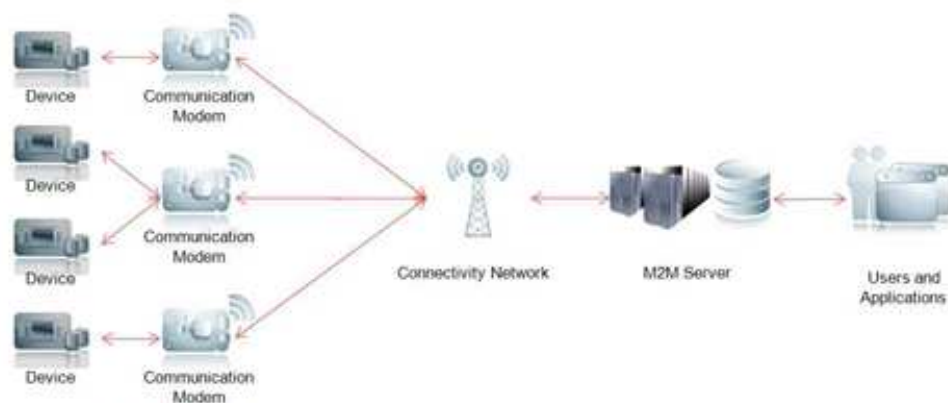

Source: (Eclipse, 2013)

Figure 49. M2M Communication integration (source: Eclipse, 2013).

7.8. Smart Education

The European Technology Platform for Future Manufacturing Technologies noted that the training of skilled workers through a new educational approach is a key factor for the success. For the new requirements of knowledge-based manufacturing it becomes necessary to introduce multidisciplinary and integrated skills in the field of engineering with the change of business models in virtual, digital and industrial processes. This makes able to keep up the increase in productivity through the management of ever more complex tasks, more effectively in the production of high value-added products. The objective of this type of environment is reflected in the need to provide qualified personnel for the integration of physical systems with digital, so effective and competent to work in the industry. The dynamic development of new solutions and the improvement of the existing becomes a basis principle throughout the business model coupled with a capacity for information and knowledge exchange in a horizontal structure.

The factories will become a platform for direct integration of the industrial environment with academic one. Through a paradigm in knowledge triangle between the activities of research, education and innovation in a common framework will provide educational and industrial experience in real-time. This will be done using physical and virtual didactic equipment so that can be used at the same time as a laboratory for research and experimentation for resolution of real industrial problems with the consequent benefit to the level of innovation.

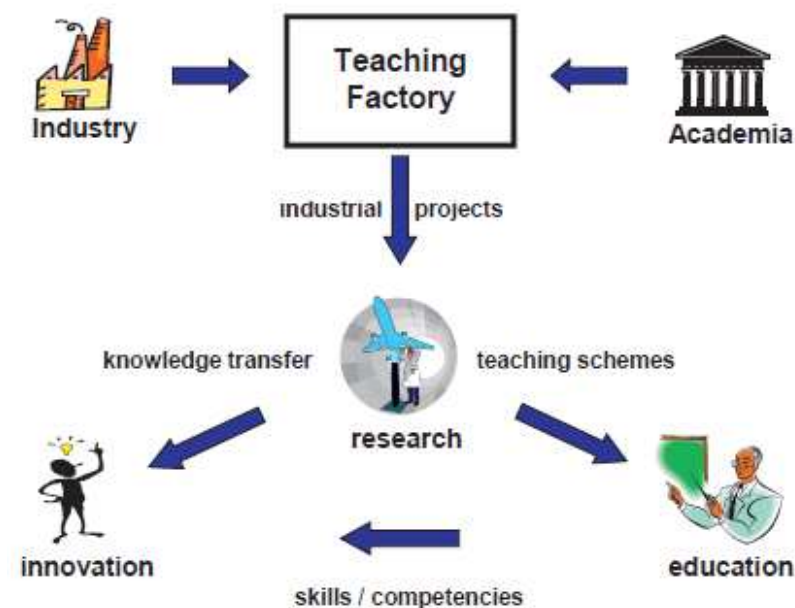

Source: (Chryssolouris, 2013)

Figure 50. The extended concept of the Teaching Factory paradigm (source: Chryssolouris, 2013).

8. Automotive, Mobility and Energy as examples of the new philosophy

Automotive

Future cars will be connected to the Internet of future. This will make them as an integral part of the global network of information able to communicate autonomously with the infrastructure and among them and optimizing its use and autonomous capacity to take decisions without human intervention based on a common regulatory and standardization. The deployment of a strategy at this level requires a change to the way of thinking in traditional industries in this sector where the traditional business models based on return generated by the sale of new vehicles must be rethought. Must be thought and structured a new corporate strategy through the entire value chain generated. Also, must be able to maintain a technological flexibility and adaptability in their ability to manufacture as well as impose the same condition to its suppliers. About 85% of suppliers still are traditional companies of medium or small size contributing up to 70% the value added to the automobile market. In future is expected the development a technological improvement at the level of the management of energy efficiency inside internal combustion engines and reduction in carbon emissions. Through the development of alternative technologies including mobility electric and hybrid adapting lightweight materials and electronics for the improvement of performance will result the development in the management of trafficking in a smart management way. At the level of the vehicle itself, the devices which allow to monitoring all the variables in action since the tire pressure until the own production will improve the ability of track in logistical terms of all the elements in the entire supply chain. This will optimize the entire workflow, managing and analyzing the data in real-time in an effective manner with the involvement of stakeholders.

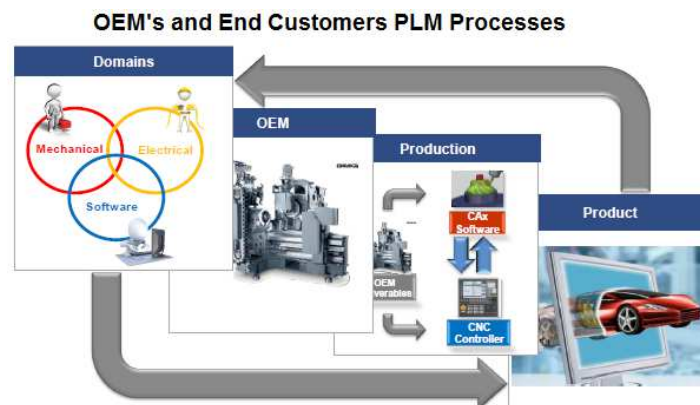

Source: (Siemens, 2013)

Figure 51. Smart manufacturing enterprise traceability (source: Siemens, 2013).

Mobility

The mobility in all aspects will be the great consequence of technological development allowed by integration of communication structures, analysis of data and equipment in society of the near future.

Despite still not be able to predict in fact the alternatives to the traditional combustion engine it becomes increasingly perceptive in which directions are being taken by means of a dynamic and innovative development (Glockner, 2013). These are continuing in open and influenced by characteristics such as the vagaries of human behavior and all the interested parties. However, it can be converted in two scenarios resulting from.

If there are no technological innovations capable in this area, the continuous increase of energy prices, legal and environmental constrains and also urban congestion will require a redesign of the role of private transport. This will force the state to take a more active role in urban environments through tighter controls and increase private taxes on the sector. This also can cause a differentiation between social classes. One social class with access to use private mobile elements and another with only access to massive use of public transportation systems or private non-motorized systems. These might cause entropy in social stability at the same time that discourages the demand for new technological innovations due to low consumption of products for private sector. This makes impossible the support of the cost of research and development.

The other scenario can be expected will be produced by the environmental awareness increasingly present in today's society, it can boost the speeding up of the implementation of new technological solutions and mobility services, not only in terms of energy efficiency, but also in supporting structures that will allow a traffic management more effective in reducing congestion through the analysis and autonomous management of information transmitted between all equipment integrated present, in real-time both in the public and private. These elements will be in symbiosis with systems of supports for driving ability in autonomous and heterogeneous communication among themselves on an open architecture, with remotely problem-solving ability. The man-machine integration leverages all the possible synergies for an effective response.

This will entail the development of a mobile society in all its dimensions social and labor, where the borders will no longer are watertight. These allow adapting to the need of each one integrating their will with the need to achieve an objective defined in their personal mobility, corporate or social in all aspects in life.

Energy

In the future, the energy infrastructures should be associated with the intelligent systems. These are capable of coordinating in real-time and are integrated into dynamic models of analysis and decision-making as well as in safeguarding their own security. The investment in renewable energies and the management of its storage becomes ubiquitous and economically efficient at level of the industry and residential in a reliable way and self sustained by balancing the demand with the supply capacity. This makes the infrastructure is more robust, flexible and adaptable to accommodate all the new technologies and current forms of consumption. This new form of management will provide the ability to achieve the objectives established without having to change lifestyles at the same time that can stimulate economic growth through innovation and investment in low amount (Martens, 2011). The level of research in some areas are proving to be a potential form of improvement in the use of energy as the search for energy storage in new types of batteries, capacitors and superconductors as the Superconducting Magnetic Energy Storage Systems designated by SMES that use magnetic fields in superconducting coils. Other development are in managing the fleet of electric vehicles connected to central management system at heights of energy peaks as an additional capacity of storage or the concerted use of renewable energy and Hydrogen as form basis for the supply of energy demand of the moment. This development will be a new generation of renewable energy with organic origin provided by biotechnology development among others.

The speed with which all stakeholders will embrace the integration of elements with a view to the reduction of environmental pollution will dictate the speed in implement these innovations. This will require investment in infrastructures needed by encouraging the creation, development and implementation of new services in the whole society, ensuring itself sustained economic and social. However, the forces present on the market alone will not be sufficient to stimulate the rapid growth of development. These will force all the necessary parties to a direct intervention with regard to legislation, incentive policies and monitoring the costs and benefits of these investments are being aligned with the models of life required by society.

For now it seems obvious that probably a single source of energy will not be able to fill all the space needed for an efficient supply of energy in the future. Probably the response will be in an integration of the management of the use of each one of these energies in a balanced way, in spite of its pros and cons.

9. Recommendations to promote *Industrie 4.0*

The permanent threat in global increased complexity of the level of technology in manufacturing processes as well as a possible frustration in the lack of updating of internal human resources can be a consequence to decline and failure of any current industrial project. Companies must accompany the dynamism of evolution of the global market. Basic Changes in strategy of internal actuation with external reflexes should be taken into account to accompany this new philosophy of strategic actions. It's necessary not continue to manage the problem how can be increased the productivity in an industrial company, but address how can it compete with more effectively. The industrial organization must worry about the implementation of a management based on the efficiency of the entire industrial structure and not only in the directly workforce. This in most cases often represents only a small percentage of the total costs. The industrial organization managers must learn how to focus in a limited and concise, but flexible way in a set of products, services, technologies, volumes and markets. This must be done in order to achieve a structure basis of production and support services focused on a task of production instead many others order inconsistent that are in conflicting with others tasks consumers of resources. Usually in traditional companies, the product development concern is obtaining the lowest manufacturing price in market and not being the best for the customer (Skinner, 2006).

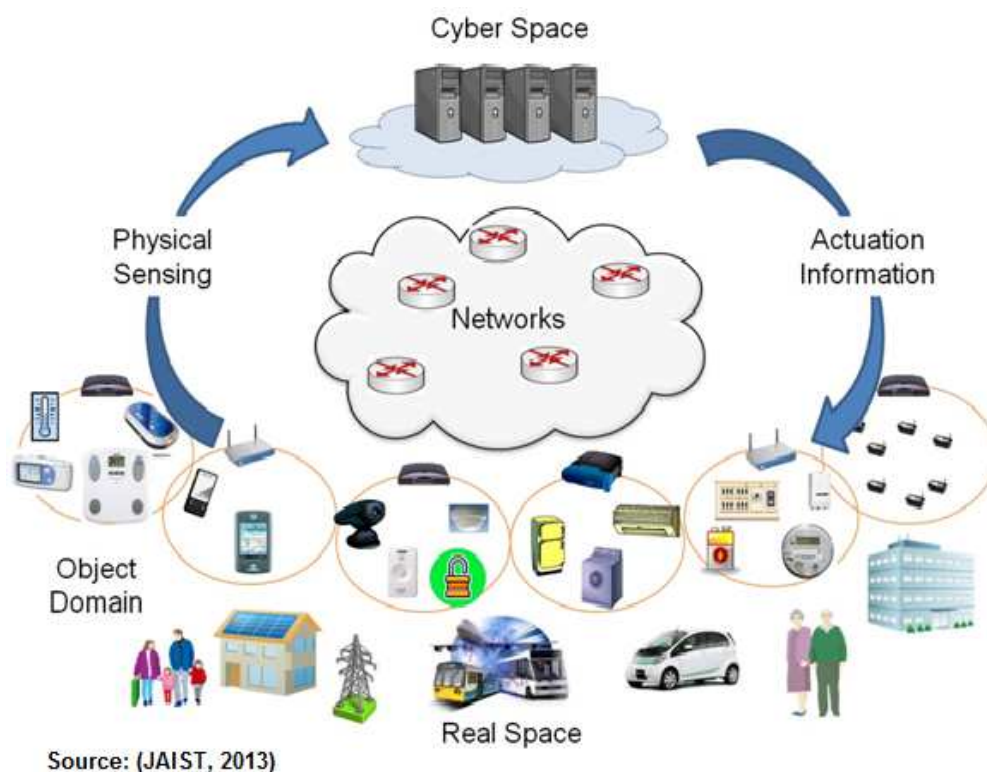

Figure 52. Cyber Physical Systems integrating society (source: JAIST, 2013).

This is contrary to the attitude taken by the national strategy proposed by the German government. This requires a new approach in many companies in the industrial sector. The investment on a market with innovative products with integration capacity as the critical element of competitive advantage must be stimulated toward a market leadership. This provides the maintenance of the technical capacity of the same leadership in the markets where want to act. It is impossible to achieve an industrial company acting with success in all areas of the market. Companies should maintain the focus on internal strategies at the level of short cycles of market delivery of products, superior quality and reliability of products into service. Also, production capacity and flexibility for the satisfaction of customer needs in markets involved should allow quickly adapting it and adjusting the volumes of production with low investment. These organizations strategies result in lower costs and higher profitability through the creation of high added value. This should be the goal to achieve in this new approach. Due to the inevitable limitation of equipment, resources and technological processes, some current strategic tasks will need to be compromised in enterprise policy in favor of other more effective and efficient. Thus, the new approach in industrial management may not be focused only on production. It should be seen as a global structural process internal with external reflexes. Analysis to all available resources involved, weaknesses and strengths inherent in the organization in the position to achieve and maintain market observing the strategic moves of competitors at the same time trying to understand the behavior and the future needs to be met the customer by integrating the entire organization in the same vision. This must be done toward a same strategic objective of sharing business corporate in line and involvement with the common national strategy. In this context, some concerns, alerts and recommendations could be addressed as:

Allocation of funds

A financing strategy of innovation is a dynamic relationship with associated risks. Projects financing not predicts that consequently will lead to good product development. Especially if there are no valid rational criteria and monitoring of investment plans through the results obtained. Understand the relationship between innovations, funding and economic growth is to accept the character of initial uncertainty of the innovation process. It must be acknowledged that the technological changes produce a climate of uncertainty for all economic factors involved in the process and society in general. Without the existence of a

strategic commitment to long-term of all, the success is not guaranteed. The typical vision of German capitalism stakeholder and interested donors reveals that are more patients to risk of investment in innovation. This allows to achieve a strategy more sustained than in countries with a type of shareholder capitalism, motivated by speculation and rapid return on investment that affect the process of innovation for the long-term (Tylecote and Visintin, 2008). Thus, the investors and legislators must understand that the relationship between the financing and the innovation must be analyzed in a dynamic context. This must be capable of dealing with the heterogeneity, amendments and the entire type of imbalances in processes likely to be influenced. Also, must predict if companies are able to survive and grow in global market. This becomes the result of processes of selection both in markets for products and services such as financial. Sometimes these are in conflict.

Understanding what type of investment becomes necessary, for an appropriate financing becomes a very important issue to be addressed. Realizing how can help innovation in small business, stimulate the creation of start-ups and rearrange the small and large undertakings through policies devoted, should be the object of distinct attention. Even companies with the same size may have different cost structures, operating in different types of markets, face different types of competition and being in different cycles of business life. These differences affect different types of need in financing and strategic alliances to accomplish goals. The industrial companies that invest more in research and design will inevitably have a greater risk. This reflects a need for funding stratified by business realities with monitoring of targets to achieve. It should not address a single to financing approach based only in administrative proceedings or political interest, too concentrated in stabilizing the financial sector in economic crisis. The stimulating agent of the national strategy should seek in create and stimulate the construction of a bridge of connection between the demand for and supply of external financing for innovative industrial companies. Some studies refer that sometimes the problem in innovation financing comes from the demand side more than the offer. This is due to the reason of many companies financial stable do not want to increase their profile of operational risk (NESTA, 2009). Create liaison officers sensitized to this theme, can increase the interest of frightened companies in accession to path of innovation. Understand that collaborative companies are those that generally have a greater impact on economic system and technological progress. In addition, a reading of the recent literature on innovation in companies reveals that firms that innovated once have the highest probability of innovating again in subsequent periods. This is due to the existence of a persistence potential in the

path of innovation as reveal some studies of the Community Innovation Survey (Duguet et Monjon, 2004; Raymond et al., 2006; Peters, 2009). This suggests that demonstrate the need to be aligned with the dominant technological regime collaboratively, which may be a valuable aid in the understanding of structuring the process of funding required to achieve the same goals at the level of the Innovation.

Market focus

The stimulation on the vision of a market leadership at the global level in the industrial sector should continue to be encouraged by the regulator and agents of support. It is suggested that the market leaders have a tendency to get more market power and competitive advantages than their rival's competitors (Ormerod, 1994). In terms of strategic management, obtaining and maintaining the leadership position may be a key goal of management. The effort to reach the top may not be the same to keep on top. Thus, strategists responsible for these financial policies in companies should pay attention in industrial markets that the leadership could become more persistent. This way can allow companies local leaders who possess strong capabilities of international competitiveness can achieve internationalization.

Becomes desirable understand that instant planning entries in markets in a global society, it is increasingly difficult to achieve in a safe way and weighted. The uncertainty and instability has become the new normality of the competitive environment. The prices of raw materials fluctuate unpredictably. The political strategies can change without prior notices. The economic cycles become shorter with crises by changing with accelerated economic growth. One of the ways that the industries have to react to the volatility of the markets is in rearrange themselves in order to adjust itself. This is done through monitoring these to improve and produce a structured reaction and rapid adaptation. This requires the abandonment of the methodology of classical planning process. It must readjust to a methodology for monitoring the growing complexity of the new reality. This is done moving away from linear hierarchical structures toward the management of the flow of capital, goods and materials in decentralized networks with a focus on point of value creation in the direction of demand and deployment of new business models.

It must be taken into account that this new form of corporate reorganization must be empowered to be able to create, introduce and to serve new markets. New and powerful competitors emerge with consequences in a constant remodeling of the chains of industrial

supplies. These will influence the macroeconomic complexity and induce geopolitical changes with exposure of some weaknesses in existing systems such as unstable economic, social and market pressures. Some protectionist policies in some nations may result in fail to have access to the new emerging markets for national industrial companies. These conditions of uncertainty must be safeguarded to prevent disruption in economic growth. It can become threats to the maintenance of the leadership in some international markets.

Communication

Stimulate cooperation between sectors is a critical factor for the success of any common strategy. Especially for the creation of innovation systems that create added value. Linking traditional industrial areas with innovative sectors, allows the production of innovation and the stimulation of new business models. The transition should be managed in such a way as fluidly, but normalized in the adoption of a common language, which all share the same orientation for the success of the deployment of Strategy 2020. This should require platforms with different skills and the ability to stimulate innovation in products and services in an organized manner. This should be complemented and geared to the success of the whole German industrial universe. History shows the failure of isolated policies in attempt to reach and establish a sustained policy of market. Only the vital involvement of all interested parties can ensure the success of strategies. The common policy may be the best policy to stimulate the development of internal and external expertise at all levels of society in a transparent, flexible and geared way. The investment in research centers and development of innovation must be the object of careful analysis by investors and regulators. Stimulate the deployment of structures, processes and mechanisms to support able to ensure timely decision-making. Stimulation the creation and development of knowledge, technologies and new products should represent a challenge sustained, coordinated and efficient. The assessments of risks, benefits, costs are complex and ambiguous. The potential solutions often result from sociological and political processes ineffective induced by pressure groups, lack of time for sustaining or integration between the interested parties. It should not be forgotten that innovation carried out in an effective way is fundamentally based on the transfer of technology and knowledge, in an effective way. Constraints on communication, organizational dispersion or rigid hierarchical functional structures in the management of these incentives may be obstacles of innovation.

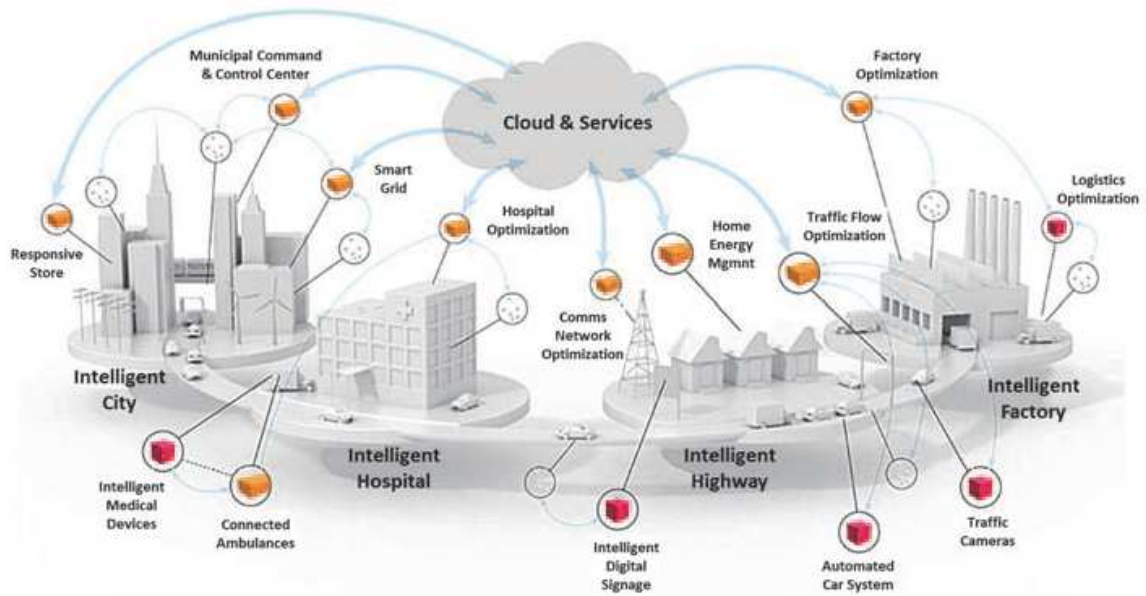

Source: (Intel,2013)

Figure 53. Communication integrating society (source: Intel, 2013).

These can also lead to ineffective or inappropriate decisions for the needs. These may cause loss of focus and waste of resources. State must be a stimulator agent of innovation in regulatory actions. The whole industry is waiting for the desired common framework in order to involve and compromising with the common strategy. A concern for stability and continuity should be taken into account to ensure that the strategic objectives to achieve do not change at the highest level. This may disturb the expectations and local industrial skills leading to an abandonment or lack of motivation of other interested parties.

Internal infrastructures

The volatility in futures markets will make difficult the maintenance of social stability in the medium term. This can cause social tensions with repercussions and implications in industrial capacity for a self-sustaining the nation. The continuous reinvestment in infrastructures efficient and competitive in the country should be a critical point to keep it in full harmony. This should be done through a public funding of support in synergy with effective private partnerships. Despite the infrastructures alone are not able to produce an added value, a scarce supply or deficient productive in capacity installed will produce an effect and negative impact on the competitiveness of the country. This can create serious obstacles mainly in the internal supply chain network.

Innovations management

The management of some dilemmas for the investment at the level of innovation must be clear so that there is no entropy capable of dispersing the resources involved or introduce mistrust of the interested parties. The local development must be done with stimulation by processes or in hierarchical form, based on creativity or in the discipline. This should be directed to the control and open-source, integrating in to direct relational communication or supported by information and communication technologies in the short or long-term. The innovation in complex environments should not be seen as a linear process. The processes of research and development cannot be measured as the repetitive processes carried out in production units. These innovative processes require a broader vision in their management and decision-making. If there is not a proper planning and management of the stimulation of innovation can lead to results that often do not intersect with the expectations created. The tight control with a pressure constant in temporal frames geared to the production of results may lead to development cycles more prolonged. The critical factor for success in innovation tends to be the timing in the introduction of a new product or service on the market. The pressure for development should not be seen solely in a prospect of short-term. Becomes desirable the stimulation in dynamic and effective investment for education of all interested parties. This should encourage and motivate all elements in a desire to anticipate the goals of long-term strategic goals in order to qualify for all the competitive advantages.

Knowledge

In a global economy, the knowledge is increasingly fast to acquire through the homogenization of the world capacity of technological networks of communication. Countries should try to attract foreign direct investment as a way of updating and maintenance of its technological innovation capacity. This will induce a strong competitive pressure among the countries with the consequent geopolitical crises. However, this desire should be object of careful analysis. The need to attract foreign investment should be applied by means of an effective organization. Establishing investments in wrong places without contributing enough to the evolution and growth of the domestic industry through the stimulation and development of the competitive skills may have impacts and negative consequences in the medium or long-term and difficult to reverse. This entails greater risks

in a decision making policy incremented by the need of national strategic decisions increasingly complex.

From the regional point of view in order to allow a viable economic growth complex, access to global markets and movement of products becomes essential as engine of prosperity. This allow mainly accelerate the introduction of innovative products that represent a plus value added. To accelerate this cycle of introduction and capitalization, the civil society, political and industrial must accept the need to recognize these benefits of potential strategic cooperation agreements. Should also commit it to transform plans into actions already that a formal agreement alone does not guarantee the real cooperation. Always keeping compliance with rules and principles that determine the sustainability of cooperation in innovation fields and finding common points in their divergences regulations and administrative requirements with a view to synergy bilateral. Also, keeping the awareness that sometimes these agreements are signed only with political purposes and not for the reasons of economic benefit that might arise. It should be in mind that some countries may try to influence the market or are influenced by corporations and domestic pressure. Representative domestic political interests can be used later as convenient excuses for failures of agenda in investment actions to innovative technological knowledge. This should be observed because the strategically decision to install a new production unit in other country is always exposed to direct factors that normally accompany the globalization. Factors such as the policies of domestic protectionism, economical adjustments, less transparent national rules and potential exposure to currency fluctuation that may incur costs not covered in their supply chains. These impacts should be analyzed and differentiated so that it is possible to develop different strategies to each necessity in order to mitigate potential impact. The more competitive and less differentiated the product is, the greater are the risks of exposure.

The role of the state should contemplate the direct support in research and development of technology and basic systems without commercial purposes. This type of technology is not radar of interest for development of private companies whose need for the creation of economic added value for their own survival the deviates from this interest. The state must ensure the use of efficient way of their own available resources such as public scientific institutions already existing, making them capable of such creation of scientific value. Simultaneously should monitor and measure the public investment made for the development of innovation in regional clusters in order to determine whether the entities

present there are able to share knowledge and relate among them at a lower cost that would be possible finding in the market. This way it is possible to increase their capacity for innovation (Porter, 2001).

Human resources

One of the most important features of differentiation for national capacity is maintaining the level of innovation required will be the capture and maintenance of human capital. This will be until a critical feature. Globally it is estimated that 10 million jobs in world industrial community are not met due to lack of skills related to the place needed to be occupied. With the growth of the emerging countries will grow also the need for specialized technicians. This will cause an increase in necessity of skilled human talent which will have implications for the acquisition and maintenance of talented specialists at a national level. This means that the interested parties should stimulate effective actions in order to attract and retain the talent in direct connection with the German industrial fabric. This way is possible ensuring a specialized technical capacity that will allow maintenance of leadership in target markets. This concern is to be considered a critical point. A country with few natural resources of value added, the technical talent will be the most valuable natural resource as the key to success of industrial competitiveness and not the access to labor costs cheaper, as one of the ways to reduce total costs. The explicit knowledge can be transferred easily by senses sensory but the innovative knowledge requires an effort of consumption of time and resources. This results in difficulty and constraints to the development process. The specialization in key areas will be the capability for the creation and development of knowledge applicable that allows the differentiation and leadership of markets.

Policy-makers

The involvement of policy-makers should be in direction of the stimulus for the economy. This should be done, in order to create jobs and stimulate the development of the domestic industry to face global competition. Stimulating external help to industries stagnant in order to seek new markets and re-balance the economy with the new generation of industries with the potential for a strong growth at the level of technological jobs. All these actions in order to promote the *Industrie 4.0*. Also, differentiating it in the global market place through the maintenance of leadership in key areas. This attitude is reflected in the

ability to respond to political pressures in certain sectors, especially in matters of competitiveness and learning with the strategic mistakes committed in the past. Is less likely failing attempting to follow the market aiming as target industries that have already demonstrated comparable and measurable advantages in a competitive way than funding technology companies with no real effective result. Private institutions create resistance to undertake investments in Research and development. Mainly internal value investments due their investment concern in internal training of the workforce. These institutions are aware that may not recover this investment if the workers themselves choose to move to a competitor. Other threat is created by market conditions putting this same innovation obtained can become obsolete when introduced.

The policy should not try to defy the natural forces of the market, but rather stimulate the simulation of these same forces in order to withdraw a favorable effect. Since that is clear, understandable and stable in the medium and long-term, will be transparent enough to allow all interested parties may engage in strategies, decisions and investments in favor of social welfare and economic. The role of the government should be entered as a facilitator to industrial activities and fomenting the competitiveness effective without interfering with the market. This interference may result negative effects, unexpected consequences for society or its external partners. The government must be also sensitive to the need to raise awareness among their own institutions for issuing research licenses and build bridges to the innovation legal procedures in order not to delay or establish barriers to the process of innovation. It should not be forgotten that the sustainability refers to the ability to ensure continuity in human society of trade-related aspects to economic, social, institutional and environmental.

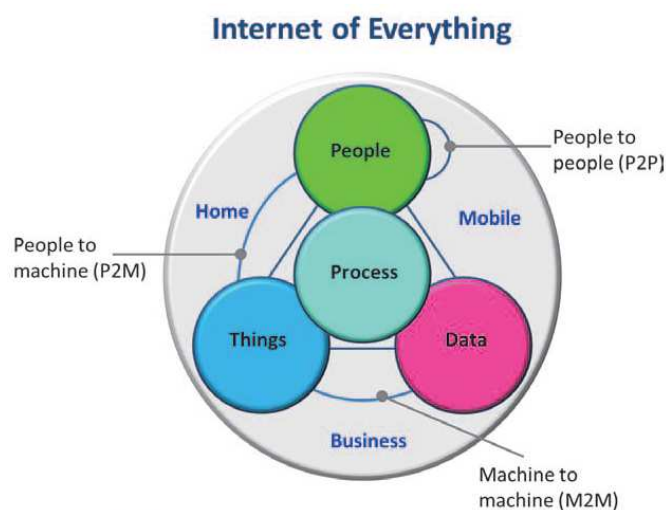

Source: (Cisco, 2013)

Figure 54. Integration of the Internet of Everything (source: Cisco, 2013).

10. Conclusions

Several conclusions were drawn along this Thesis, in their direct and indirect relations between the most diverse characteristics that embody this theme.

Themes such as the training and the sharing of best practices among all those involved must be not only encourage, but also monitored and evaluated These allow being possible to implement a new industrial philosophy capable of reaching the entire efficiency potential. Also, should create and reinforcing developmental capacity the necessary infrastructures to allow the management of large amounts of data and information that Cyber-Physical Systems will require without forgetting to ensure its integrity and security. Internet of Things allows to all stakeholders managing in a simple, available and economically feasible way the entire chain of value creation. However, the most profound change will be at the level of the change of culture and mentality in how the manufacturing, integration and interaction have been seen in industrial production over the course of time. This will require a complete reorganization of the concept of work and the role of the human being as productive element. The answer may be based on effort applied between the synergistic fusions of human creative talent with the technological development available. The development of the interaction Human-machine and Human-system will require a whole new recasting of society in its legislative adjustment of laws such as the work and private life. These with impact on the entire social structure and labor where the borders will no longer have strict limits and the risks will be managed in the whole range policy, social and labor aiming at a common interest. The paths of this new industrial philosophy already have their foundations and goals defined: concerns such as the aging of the active population, the loss of competitiveness in the world market in relation to the emerging countries, the efficient management of mainly resources more critical as the energy and finite raw material, the easing of industry in search of optimization along the entire chain of value creation. All these issue has been the object of intense research for which Germany is able to not only continue to improve while economy at a global level, but maintain a level of stability in quality of life and social peace. Some vital concerns should be the object of careful attention as the management of priorities. The interested parties must accept that not all challenges identified to be exceeded should be object of equal importance. Exist the risk of losing focus and energy expenditure in collective effort undertaken to promote synergy and collaborative understanding in order to unite around this common strategy.

11. Bibliography References

- ABB** (2010): *Industrial Smart Grid*, ABB Industries.
- ACATTECH** (2013): *Recommendations for implementing the strategic initiative Industrie 4.0*, German National Academy of Science and Engineering.
- ACATTECH** (2012): *Integrated research agenda Cyber-Physical-System*, German National Academy of Science and Engineering.
- ACATTECH** (2011): *Cyber-Physical-System: Innovationsmotor für Mobilität, Gesundheit, Energie und Produktion*, German National Academy of Science and Engineering.
- Agrawal, S.; Vieira, D.** (2013): *A survey on Internet of Things*, Abako's.
- Almeida, M.; Moraes, C.** (2013): *Diffusion of emerging technologies for sustainable development: Perspective assessment for public policies*, Journal Technology Management Innovation, Vol. 8, p.228-238.
- Alptekin, S.** (2001): *Teaching Factory*, American Society for Engineering Education, US.
- Atzori, L.; Lera, A.; Morabito, G.** (2010): *The Internet of Things: A survey*, Computer Networks 54, p. 2787-2805.
- Babulak, E.** (2010): *The 21st Century Cyberspace*, Applied Machine Intelligent and Informatics, SAMI.
- Bagajewicz, M.** (2009): *Smart Process Plants*, McGrawHill.
- Bahar, D.; et al.** (2013): *Neighbors and the evolution of the comparative advantage of Nations: evidence of international knowledge diffusion*, Harvard Editions.
- Bathelt, J.; et al.** (2010): *Factory of the Future enabled by the Virtual Factory Framework*, DAAAM.
- BDI** (2011): *Germany 2030: Future perspectives for value creation*, Federation of German Industries.
- Bernaden, J.** (2013): *Indirect Jobs: A direct way to talk about why we need Smart Manufacturing*, Rockwell Automation.
- Beymonti, N.** (2006): *The impact of technological innovation on organizations, work environment and personal lives*, PICMET2006, Istanbul.
- BMBF** (2012): *Recommendations for the future project Industrie 4.0*, Federal Ministry of Education and Research.
- BMBF** (2012): *Autonomik für Industrie 4.0*, Federal Ministry of Education and Research.
- BMBF** (2010): *Ideas. Innovation. Prosperity. High-tech Strategy 2020 for Germany*, Federal Ministry of Education and Research.
- BMWi** (2010): *In focus: Germany as a competitive industrial nation*, Ministry of Economics and Technology.
- Brikova, I.** (2006): *Determinants of the international competitiveness of national regions in the Global Economic Environment*.
- Broy, M.** (2006): *Challenges in automotive software engineering*, Technische Universität München, p. 33-41.
- Buratti, C.; Conti, A.; Dardari, D.; Verdone, R.** (2009): *An overview on Wireless Sensor Networks technology and evolution*, Sensors, N.9, p. 6869-6896.

- Campbell, R.; Garrett, G.; McGrath, R.** (2007): *Cyber Physical Systems: Position Paper*, Siebel Center for Computer Science.
- Carter, A** (2013): *Mass-customization through Digital Manufacturing*, Auburn University, USA.
- CERP-IoT** (2010): *Vision and Challenges for realizing the Internet of Things*, Cluster European Research Projects on Internet of Things.
- Chadha, S.; Singh, M.; Pardeshi, S.** (2013): *Bluetooth Technology Principle, Application and current status*, IJCSC, Vol. 4; N.2; p. 16-30.
- Chen, M.; Jin, H.** (2013): *Enabling technologies for future data center networking*, IEEE, Vol. 27, p. 8-15.
- Chryssolouris, G.; et al.** (2013): *Manufacturing Systems: skill & competencies for the future*, Procedia CIRP, Vol. 7, p. 17-24.
- Clausen, T.; et al.** (2011): *Innovation strategies as a source of persistent innovation*, Oxford University Press, p. 553-585.
- Colombo, A; Karnouskos, S.; Bangermann, T.** (2013): *A System of Systems view on Collaborative Industrial Automation*, p. 1968-1975.
- Cook, J.** (2006): *Cyber Physical Systems and the Twenty-first century automobile*.
- Covington, M.; Carskadden, R.** (2013): *Threat Implications of the Internet of Things*, NATO CCD COE Publications.
- CyPhERS** (2013): *Characteristics, capabilities, potential applications of Cyber-Physical Systems: a preliminary analysis*, CyPhERS.eu – Cyber-Physical European Roadmap & Strategy.
- Dalsoto, F.; et al.** (2013): *Data Analysis Module for wireless HART Network Planning*, IEEE, p. 23-28.
- Deloitte** (2012): *Digital-Age Transportation: The future of mobility*.
- Dillon, T.; Chang, E.; Wallis, S.** (2013): *Cyber-Physical Systems and Cloud Ecosystems*, IEEE.
- DMRC** (2011): *Thinking ahead the future of Additive Manufacturing: Analysis of promising Industries*, Direct Manufacturing Research Center, University of Paderborn, Germany.
- DTTL** (2012): *Reigniting growth: Advanced Materials System*, DTTL Global Manufacturing Industry Group.
- DTTL** (2009): *A new Era: An automotive industry transformed*, DTTL Global Manufacturing Industry Group.
- Dumitrache, I; et al.** (2013): *From mass production to Intelligent Cyber Enterprise*, University Politehnica of Bucharest, Romania.
- Economist** (2012): *Manufacturing and Innovation: A Third Industrial Revolution*, The Economist, USA.
- EFFRA** (2012): *A Manufacture Initiative*, European Factories of the Future Research Association.
- EFFRA** (2010): *Factories of the future PPP: Strategic multi-annual Roadmap*, European Factories of the Future Research Association.
- Etemad, K.** (2008): *Overview of Mobile Wimax technology and evolution*, IEEE, p. 31-40.
- Ferber, S** (2013): *Internet of Things in production: Industrie 4.0*, Bosch AG.
- Ferrazi, M.; et al.** (2011): *The new geography of automotive manufacturing*, Chatham House.

- FIAO** (2013): *Manufacturing work of the future – Industrie 4.0*, Fraunhofer Institute for Industrial Engineering.
- FIAO** (2013): *Studie Produktionsarbeit der Zukunft – Industrie 4.0*, Fraunhofer- institut für arbeitswirtschaft und organisation, Germany.
- FIAO** (2013): *Industrie 4.0: Information technology is the key element in the factory of the future*, Fraunhofer- institut für arbeitswirtschaft und organisation, Germany.
- FIAO** (2013): *Essay Industrie 4.0*, Fraunhofer- institut für arbeitswirtschaft und organisation, Germany.
- Fischer, J.** (2013): *Die (digitale) fabric der zukunft*.
- Fischer, G.; et al.** (2013): *The Bridge*, National Academy of Engineering, Vol. 33, N. 2, USA.
- Forschungsunion** (2013): *Prosperity through research: what task lie ahead for Germany?*, Industry Science Research Alliance, Germany.
- GAO** (2013): *Global manufacturing: Foreign Government Programs differ in some key respects from those in the US*, United States Government Accountability.
- GIMÉLEC** (2013): *Industrie 4.0: Lúsine connectée*.
- Glockner, H; Rodenhouses, B.** (2008): *The future of mobility*.
- Graube, M. et al.** (2013) *Linked data as enabler for mobile application for complex tasks in industrial settings*, IEEE.
- Green, J.** (2007): *Democratizing the future towards a new era of creativity and growth*, Philips Editions.
- GTAI** (2012): *The automotive industry in Germany*, Germany Trade & Invest.
- Gubbi, J.; et al.** (2013): *Internet of Things (IoT): A vision, architectural elements and future directions*, Future Generation Computer Systems, 29, p. 1645-1660.
- Gupta A.; et al.** (2013): *Future of all technologies – the Cloud and Cyber Physical Systems*, International Journal of Enhanced Research in Science Technology & Engineering, v. 2.
- Haller, S.** (2012): *IoT Reference Model White Paper*, Internet of Things Institute.
- Hausmann, R.; Hidalgo, C., et al.** (2008): *The Atlas of economic complexity: mapping paths to prosperity*, Harvard & MIT editions.
- Heijester, J; Huijbers, S.** (2013): *Future of automotive manufacturing*, Automotive Technology Centre.
- Hepburn, D.** (2011): *Mapping the World's changing industrial landscape*, Chatham House
- Hekkert, M.; et al.** (2007): *Functions of innovation systems: A new approach for analyzing technological change*, p. 413-412.
- Huebner, A.; et al.** (2013): *RFID Systems from a Cyber-Physical Systems Perspective*.
- Hurlburt, G; Voas, J.** (2013): *Beyond the Cloud: Cyberphysical Systems*, IEEE Computer Society.
- IDA** (2012): *Emerging global trends in advanced manufacturing*, Institute for Defense Analyses, USA.
- IMS2020** (2010): *Roadmap on Sustainable Manufacturing Energy Efficient Manufacturing and Key Technologies*, Intelligent Manufacturing Systems IMS2020 Consortium.
- IOTSIG** (2013): *IoT and M2M: Challenges and opportunities*, Internet Of Things Special Interest Group.
- Jensen, K.; Evensberget, M.** (2013): *Managing WirelessHART: Developing a network manager*, University of Oslo, Sweden.

- Jiafu, W.; et al.** (2013): *From Machine-to-Machine Communications towards Cyber-Physical Systems*, ComSIS, Vol. 10, N. 3.
- Jovane, F.; et al.** (2009): *The ManuFuture Road: towards competitive and sustainable high-adding-value manufacturing*, Springer.
- Karimi, K.; Atkinson, G.** (2013): *What the Internet of Things needs to become a reality*.
- Kato, M.; Houjo, Y.** (2009): *The persistence of market leadership: evidence from Japan*, Oxford University Press, p. 1107-1133.
- Kim, S.; et al.** (2013): *No battery required: Perpetual RFID - Enabled wireless sensors for cognitive intelligence applications*, Georgia Institute of Technology, USA.
- Kinney, P.** (2003): *ZigBee Technology: Wireless control that simply works*, IEEE.
- Koprivica, M.** (2013): *Self-Adaptive Requirements Aware Intelligent Things*, International Journal of Internet of Things, p. 1-4.
- Kranenburg, R.; et al.** (2011): *The internet of things*, 1st Berlin Symposium on internet and society paper.
- Kranenburg, R.; et al.** (2008): *The internet of things: A critique of ambient technology and the all-seeing network of RFID*, Institute of Network Cultures, Amestardan.
- Kubach, V.** (2011): *EU Reserach Portfolio of Smart Manufacturing Projects*, SAP Research Center Dresden.
- Kumar, R.; Ray, A.; Kande, M.** (2013): *WirelessHART device integration challenges and solutions in industrial automation*.
- Kushwaha, D.** (2013): *Application of Bluetooth Wireless Technology*, International Journal of Mathematics and Computer Research, Vol. 1, p. 79-82.
- Lange, S. et al.** (2011): *IoT: Architectural Reference Model*.
- Lee, E.** (2008): *Cyber Physical Systems: Design Challenges*, Center for Hybrid and Embedded Systems, University of California, P. 363-368.
- Lee, J.; et al.** (2013): *Recent advances and trends in predictive manufacturing systems in big data environment*, Manufacturing Letters Vol. 1, p. 38–41.
- Ma, X.; Luo, W.** (2008): *The analysis of 6 LowPAN Technology*, IEEE, p. 963-966.
- Martin R.** (2004): *A study on the factors of regional competitiveness*, University of Cambridge.
- Mayordomo, I.; et al.** (2013): *An overview of technical challenges and advances of inductive wireless power transmission*, Fraunhofer Institute for Integrated Circuits, Germany.
- Mazhelis, O.; et al.** (2013): *Internet o Things: market, value networks and business models*, University of Jyväskylä.
- Mazzucato, M.** (2013): *Financing innovation: creative destruction versus destructive creation*, Oxford University Press, p. 851-867.
- Mehra, H.** (2013): *Factory of the future*, Tata Consultancy Services.
- Minoli, D.** (2013): *Building the Internet of Things with IPV6 and MIPV6: The evolving world of M2M Communications*, John Wiley & Sons, Inc.

- Mokyr, J.** (1985): *The New Economic History and The Industrial Revolution*, Rowan & Littlefield Publishers Inc., USA.
- Mokyr, J.; Strotz, R.** (1998): *The Second Industrial Revolution*, Northwestern University, p. 1870-1914.
- Mulligan, G.** (2007): *The LowPAN Architecture*, Nets, p. 78-82.
- Murkowski, L.** (2013): *Energy 2020: A vision for America's energy future*, United States Senate.
- NIC** (2008): *Disruptive Civil Technologies: six technologies with potential impacts on US interest out to 2025*, National Intelligence Council, USA.
- NIST** (2013): *Foundation for innovation in Cyber Physical Systems*, National Institute of Standards and Technology, US Department of Commerce.
- NIST** (2013): *Strategic Vision and Business Drivers for 21st Century in Cyber Physical Systems*, National Institute of Standards and Technology, US Department of Commerce.
- NIST** (2012): *Cyber-Physical Systems: Situation Analysis of Current Trends, Technologies, and Challenges*, National Institute of Standards and Technology, US Department of Commerce.
- OECD** (2012): *OECD Economic Surveys: Germany*, OECD Publishing.
- Oracle** (2011): *The future of energy*, Future Poll, UK.
- Pang, Z.** (2013): *Technologies and architectures of the internet of things for health and well being*, KTH-Royal Institute of Technology, Sweden.
- Pastor, A.** (2011): *Internet of Things architecture requirement list*.
- Pramudianto, F. ; et al.** (2013): *Prototyping the Internet of Things for the Future Factory Using a SOA-based Middleware and Reliable WSNs*, IEEE.
- Putten, B.; Kuestner, M.; Porgat, M.** (2009): *The Future Factory Initiative at SAP Research*, SAP Research Center Dresden, Germany.
- Rajkumar, R.; Lee, I.; Stankovic, J.** (2010): *Cyber Physical System: The next computing revolution*, ANC, USA, p.731-736.
- Remke, A.; Wu Y.** (2013): *WirelessHart modeling and performance evaluation*, IEEE.
- Rockwell Automation** (2013): *Smart Manufacturing*, USA.
- Rolandberger** (2011): *E-Mobility: A promising field for the future*, Roland Berger Strategy Consultancy.
- Rifkin, J.** (2013): *The Third Industrial Revolution*, The World Financial Review, p. 8-12.
- Runde, S.; Wolf, G.; Braun, M.** (2013): *EDDL and Semantic web: From Field Device Integration (FDI) to Future Device Management (FDM)*, IEEE.
- Saeco, M.; Pedrazzoli, P.; Terkaj, W.** (2013): *Virtual Factory Framework*, Institute of Industrial Technologies and Automation, National Research Council.
- Samad, T.; Stewart, G.** (2013): *Perspectives on Innovation in control systems technology: Compatibility with industry practices*, IEEE, Vol. 21, p. 284-288.
- Sand, G.; Terwiesch, P.** (2013): *Closing the loop: an industrial perspective on the present and future impact of control*, European Journal of Control, v. 19, p.341-350.
- Santucci, G.; Andersen, S.** (2012): *Inspiring the Internet of Things*, Alexandra Institute, UK.

- Sarwar, U; et al.** (2010): *Architecture for 6LoWPAN Mobile Communicator System*, International Multiconference of Engineers and Computer Scientists, Vol. II.
- Satlk, G.; Evans, P.; Schulman, L.** (1992): *Competing on capabilities: The new rules of corporate strategy*, Harvard Business Review, p. 57-59.
- Schlick, J.** (2012): *Cyber Physical Systems in factory automation*, DFKI GmbH, Germany.
- Sha, L.; et al.** (2008): *Cyber Physical Systems: anew frontier*, IEEE Computer Society.
- Siemens** (2013): *Operational Guidelines for Industrial Security*, Siemens AG.
- Siemens** (2013): *Shaping the Future Production with Siemens: on the way to Industry 4.0*, Siegfried Russwurm.
- Siemens** (2013): *Industry 4.0: the path from research to practice*, Wolfgang Heuring.
- Silva I.; et al.** (2013): *Tecnologias emergentes para redes industriais sem fio: WirelessHART VSISA100*, Instituto Brasileiro de Petróleo, Gás e biocombustíveis, Brasil.
- Skinner, W.** (1974): *The focused factory*, Harvard Business Review, p. 113-121.
- Smith, I.** (2012): *The Internet of Things: New horizons*.
- Smith, P.** (2011): *Comparison between Low Power Wireless Technologies*, CRS.
- SMLC** (2011): *Implementing 21st Century Smart Manufacturing*.
- Sobrinho, O.; Cuguasca, C.** (2013): *An overview of the EPC Global Network*, IEEE, Vol. 11, p.1053-1059.
- Spath, D.; Gerlach, S.** (2012): *Cyber Physical System for self-organized and flexible labor utilization*, Fraunhofer-Institut, Germany.
- Stavropoulos, P.; et al.** (2013): *Monitoring and control of manufacturing processes: a review*, Procedia CIRP 8, p. 421-425.
- Stojmenovic, I.** (2013): *Large Scale Cyber-Physical Systems: Distributed Actuation, In-Network Processing and Machine-to-Machine Communications*, MECD - 2013 & ECyPS'2013, Montenegro.
- SUMMIT** (2013): *Cyber Physical Systems*, SUMMIT Organization.
- Tamura, T.; Masuda, I.** (2013): *Device connectivity technologies using short-distance wireless communications*, Fujitsu Science Technological Journal, Vol. 49, N.2, p. 213-219.
- Tan, L; Wang, N.** (2010): *Future Internet: The Internet of Things*, IEEE, Vol. 5, p. 376-380.
- Thomas A.; Treutesaux, D.** (2013): *Are Intelligent Manufacturing System sustainable?*
- Thomke, S.; Hippel, E.** (2002): *Customers as innovators: A new way to create value*, Harvard Business Review, p. 5-11.
- TI** (2014): *Wireless Connectivity*, Texas Instruments Incorporated, US.
- Tolio, T; et al.** (2013): *Virtual Factory: an integrated framework for manufacturing systems design and analysis*, Procedia CIRP, Vol. 7, p. 25-30.
- Tsahalis, J.; et al.** (2012): *Towards a holistic optimization of production sustainability: A multi-level approach*, Technological Educational Institute of Athens.
- UNEP/IEA** (2007): *Analyzing our energy future*, United Nations Environment Programme and International Energy Agency.
- UNIS** (2013): *Final Architectural Reference Model for IoT V3.0*.

- Vergragt, P.** (2006): *How technology could contribute to a sustainable world*, Tellus Institute.
- Vermaas, R.** (2013): *The security risks of Mobile Payment Applications using Near Field Communication*, Erasmus University Rotterdam.
- Vermesan, O.; et al.** (2013): *Internet of Things: converging technologies for smart environments and integrated ecosystems*, River Publishers.
- Vermesan, O.; et al.** (2012): *Internet of Things Strategic Research Roadmap*, pp. 10-49.
- VTT** (2013): *Productivity Leap with IoT*, VTT Technical Research Centre of Finland.
- Wachs, M.** (2013): *NFC-Possibilities and risks, Network Architectures and Services*, Technische Universität München.
- Wahlster, W** (2013): *Industry 4.0: The Semantic Product Memory as a Basis for Cyber Physical Production Systems*, German Research Center for Artificial Intelligence.
- Wan, J.; et al.** (2013): *Cyber-Physical Systems for optimal Energy Management Scheme of Autonomous Electric Vehicle*, The Computer Journal Advance.
- WB** (2011): *Multipolarity: the new global economy*, The World Bank.
- WEF** (2012): *The future of manufacturing: opportunities to drive economic growth*, World Economic Forum.
- Weihrich, H.** (1999): *Analyzing the competitive advantages and disadvantages of Germany with the Tows Matrix-An, alternative to Porter's Model*, European Business Review, p. 1-18.
- Westkämper, E.** (2006): *Digital manufacturing in the global Era*, p. 1-11.
- WEC** (2007): *Deciding the future: Energy police scenario to 2050*, World Energy Council.
- WEF** (2013): *Energy Vision 2013: Energy transitions, past and future*, World Economic Forum Industry Vision.
- Wi-Fi ALLIANCE** (2014): *Connect your life: Wi-Fi^R and the Internet of Everything*, Wi-Fi ALLIANCE, US.
- Wimax Forum** (2006): *Mobile Wimax: A Technical overview and performance evaluation*.
- Wolf, T.; Zink, M.; Nagurney, A.** (2013): *The Cyber-Physical Marketplace: A Framework for Large-Scale Horizontal Integration in Distributed Cyber-Physical Systems*, IEEE.
- WTO** (2012): *International Trade Statistics 2012: World exports 2011*, World Trade Organization.
- WTO** (2012): *Trade Profiles 2012: Trade flows and trade policy measures*, World Trade Organization.
- Wu, D.; Greer, M.; Rosen, D. Schaefer, D.** (2013): *Cloud Manufacturing: Strategic Vision and state of the art*, Journal of Manufacturing Systems.
- Yashoda, T; Rao, S.; Kedarmath, G.** (2013): *Design and implementation of embedded Bluetooth Multicast System*, International Journal of Engineering Research & Technology.
- Yoshikawa, H; et al.** (2008): *The incoming global technological and industrial revolution towards competitive sustainable manufacturing*, CIRP Annals Manufacturing Technology, V. 57, p. 641-659.
- Yu, G.; Zhang, H.** (2011): *Speed up the strategy of the Internet of Things Industry*, IEEE.
- Zedtwitz, M.; et al.** (2004): *Organizing global R&D: challenges and dilemmas*, Elsevier Inc., p. 21-49.

Zhang, L.; He, J.; Yu, W. (2013): *Challenges and Solutions of Cyber Physical Systems*, Shanghai Key Laboratory of Trust Worthy Computing, China.

Zhang, L. et. al. (2013): *Challenges, Promising Solutions and open Problems of Cyber Physical Systems*, International Journal of Hybrid Information Technology, Vol. 6, P. 66-73.

Zhen-Jun, G. (2013): *Research on key technologies and applications of Internet of Things*, IEEE, p. 2797-2801.

ZigBee ALLIANCE (2011): *ZigBee and Wireless Radio Frequency Coexistence*, ZigBee ALLIANCE Organization.

12. Glossary

3D Printer - Equipment that allows printing 3-dimensional parts from digital information (Carter, 2013).

Active Digital Entity - Active code or software program, usually acting according to a business logic (IoT-A, 2012).

Actuator - Mechanical device for moving or controlling a system (Sclater, 2007).

Adaptivity - Ability of a system and its behavior in a situation (acatech, 2012).

Additive Manufacturing - Process of three-dimensional construction of a solid object from a digital elevation model (Carter, 2013).

Agility - Strategic capacity of an entire structure in developing production capacity needed (Wiendahl et al. , 2007).

Application Platform - Technical and organizational operation and development platform (acatech, 2012).

Architectural Reference Model - Describes the methodology with which the reference model and the reference architecture are derived, including the use of internal and external stakeholder requirements (IoT-A, 2012).

Architecture - Fundamental organization of a *system* embodied in its components, their relationships to each other, and to the environment, and the principles guiding its design and evolution (IEEE-1471-2000)

Association - Establishes the relation between a *service* and *resource* on the one hand and a *Physical Entity* on the other hand (IoT-A, 2012).

Augmented reality - Systems that can report context-sensitive information when people come into proximity with other people, places and things (SRI, 2013).

Autonomy - Ability of a system to decide and act independently (acatech, 2012).

Best Practice - Proven best or exemplary method or procedure (acatech, 2012).

Business model - A simplified representation of a company and an abstraction of how its business and value added work.

Business to Business - Business relations between at least two companies.

Business to consumer - Relations between businesses and consumers.

Business Web - Network of companies with create partial services complement each other.

Capability architecture - Description of the functionality of a system, as well as the structure of the system and their interactions from terms in functions.

Changeover ability – Operational Ability that a machine or workstation has to perform a certain operation at any height that is required using the minimum effort and delay (Wiendahl et al. , 2007).

Cloud - Elastic execution environment of resources involving multiple stakeholders and providing a metered service at multiple granularities for a specified level of quality of service (CORDIS, 2010)

Cloud Computing - The use of Informatics Technologies resources from the cloud.

Cluster - Group of values or data objects with similar properties.

Context awareness - Ability of systems to capture, identify and process situation knowledge.

Customization – Processo pelo qual se altera um produto base de uma maneira específica para satisfação dos requisitos e especificações de uma procura (Carter, 2013).

Cyber Crime - Non-legal activities or allowed with a view to financial gain that exploit vulnerabilities of electronic systems (Oracle, 2011).

Cyber-Physical System - Embedded systems, logistics, co-ordination and management processes as well as Internet services (acatech, 2012).

Data Mining - Procedure for recognition of relationships in large amounts of data for specific purposes.

Data Model – An abstract model able to describe how the data is represented and accessed (VFF, 2013).

Device - Technical physical component (hardware) with communication capabilities to other Informatics Technology systems (IoT-A, 2012).

Digital Entity - Computational or data element of an Informatics Technology based system (IoT-A, 2012).

Digital Factory – Various activities of a plant through a virtualized environment, capable of sharing data among themselves and information relating to resources, productive activities and integrated knowledge in a collaborative simulation in designing, planning, production and management between all actors (VFF, 2013).

Energy efficiency - Ability of a system to provide its functionality with minimum energy consumption.

Flexibility – Agility in the amendment of a whole area logistics or production in less time possible to operate with a new and similar family of elements through the amendment of the production process, flow of materials or logistics (Wiendahl et al. , 2007).

Functional safety - Absence of unacceptable risks due to hazards posed by a behavior of a system.

Human-machine interaction (MMI) - Design of interactive systems and their human-machine interfaces.

Human-machine interface - Interface between people as users and computerized systems.

HSM - Cryptographic coprocessor and provides a secure execution environment for cryptographic operations.

Intelligent Device - Physical object with an embedded processor, memory, and a network connection with the ability to interact with its physical environment.

Intelligent Infrastructure - Technical infrastructure components and systems, as well as embedded control components for monitoring and analysis of complex processes.

Intelligent Embedded System - Embedded System with adaptive or autonomous skills.

Intelligent Sensor - A sensor with actual input value capturing, local processing of the measured data and signal processing in a housing together.

Internet - A global computer network providing a variety of information and communication facilities, consisting of interconnected networks using standardized communication protocols (Oxford English Dictionary).

Internet of Things (IoT) - The global network connecting any smart object (IoT-A, 2012).

Interoperability - The ability to share information and services by two or more systems or components (TOGAF 9).

IP - Internet Protocol, method or protocol by which data is sent from one computer to another on the Internet (Rouse, 2008).

Machine Learning - Generic term for techniques, with which the computer can generate knowledge from experience.

Machine to Machine (M2M) - Automatic communications between *devices* without *human* intervention (COMPDICTM2M).

Mixed Reality (MR) – Combination defined between the real environment perceived by humans and the virtual environment created by a computer (Milgram, 1994).

On request - Indicating that requests to a desired time by the user or customer can be met (acatech, 2012).

Open Source - Readable program code of Open Source Software can publicly viewed and under the conditions of open source licenses used, modified and distributed.

Personal data - A specific natural person associated or indirectly allocable data.

Physical Entity - Physical object that is relevant from a user or application perspective (IoT-A, 2012).

Plug-and-play - Technology, without user interaction in a device or system that it works out of the box.

Policy - Regulatory framework, definition, directive.

Reconfigurability – Agility of a system of production or assembly to adapt and operate with certain families of products using the minimum delay, through the addition or removal of functional elements (Wiendahl et al., 2007).

Reference Architecture - Architectural design pattern that indicates how an abstract set of mechanisms and relationships realizes a predetermined set of requirements (IoT-A, 2012).

Reference Model - Abstract framework for understanding significant relationships among the entities of some environment (OASIS-RM)

RFID - Electromagnetic or inductive coupling in the radio frequency portion of the spectrum to communicate to or from a tag through a variety of modulation and encoding schemes to uniquely read the identity of an RF Tag (ISO/IEC 19762).

Real-time capability - Ability of a system, guaranteed response times.

Requirements Specification – Sets the requirements for a system from the point of view of the user and other Stakeholder (acatech, 2012).

Requirements traceability process – Ability to meet specified requirements in the design, implementation and further development of systems, subsystems and components (acatech, 2012).

Robustness - Ability of a system to respond to errors and unforeseen conditions so that there is no faulty actions.

Safety - Absence of unacceptable risks in the operation of the system (acatech, 2012).

Security - Ability of a system to expected to be fault-free and safe operation.

Self Awareness - Ability of systems or processes, to analyze their own condition.

Self Healing - Ability of systems or processes, to correct faults independently.

Self-organization - Transition from a disordered condition in an orderly condition.

Semantic Interoperability - The ability of computer systems to the mutual exchange and matching interpretation of information.

Sensor - Device that perceives certain characteristics of the real world and transfers them into a digital representation (IoT-A, 2012).

Service - An abstract concept for functions and services of systems, and people.

Shared Control - Between man and System shared control of a highly automated system.

Simulation – Mathematical modeling and tomography for the imitation of a system during a specified time period with the purpose to understand its behavior and assess at the same time the system itself (VFF, 2013).

System - A collection of components organized to accomplish a specific function or set of functions (IEEE-1471-2000).

Smart Environment – It is an environment that uses information and communication technologies to optimize, manage and make more effective interactive systems management components of critical infrastructures (Forrester, 2010).

Smart Grid - Intelligent electrical grid able to anticipate and react to the behavior of the needs of all the electrical components interconnected (Oracle, 2011).

Smart Label - Is an item identification slip that contains more advanced technologies than conventional bar code data (Rouse, 2008).

Smart Meters - Gauges capable of storing and communicating information in both directions, in real time (Oracle, 2011).

Smart Object - Device able to sense or interact with the environment, and uniquely identifiable (Kranenburg, 2011).

Smartphone - Cellular telephone with an integrated computer and other features not originally associated with telephones, such as an operating system, Web browsing and the ability to run software applications (Rouse, 2008).

Stakeholders - Any natural or legal persons or interest groups, are affected and thus an interest in the progress and outcome of its development and use.

Tailoring - Tailored to a specific request or application.

Technical architecture - Presentation of the concrete technical dimensioning, realization and structuring of a system.

Technical interoperability - The ability of computer systems to exchange data.

Telematics – Interconnection of communication technology with the computing science (Acatech, 2012).

Things - Active Participants in the processes of information, communication, social and business model where are interconnected through the exchange of data between themselves or between the environments at the same time that react autonomously through processes with actions to events triggered with or without direct human intervention (CERP IoT, 2010).

Transformability – Agility tactic of an entire industrial structure for changing the family of products (Wiendahl et al. , (2007).

UID - Unique IDentifier, is a numeric or alphanumeric string associated with a single entity within a given system, so that it can be accessed and interacted with (Rouse, 2008).

Ubiquitous Computing - Omnipresence computerized information processing.

Upgradeability - Ability of a system through updates of data and programs with the latest technical or substantive progress (acatech, 2012).

Usability – Suitability for the task (ISO-standard 9241-110).

Validation - Check the explicit or implicit requirements of a system during or at the end of the development process, in order to check that the system meets the expectations and needs of stakeholders.

Value Chain - Model of value added than sequential, graduated string of activities or processes, from development to production to marketing and services.

Virtual Engineering – Education of engineers through the work with virtual products (Acatech, 2012).

Virtual Environments – Realistic Simulations of scenarios interactive (VFF, 2013).

Virtual Entity - Computational or data element representing a *Physical Entity* (IoT-A, 2012).

Virtual Reality – Interactive simulation of real or imaginary environments (Lanier, 2010)

Wireless - Telecommunications in which electromagnetic waves carry the signal over part or all of the communication path (Rouse, 2006).

X-awareness – Ability of perception and interpretation of situations and contexts, with the inclusion of objectives, states, intentions of actions and intentions of the people involved in the system or process (Acatech, 2012).

Appendix I

Technologies involved in vision *Industrie 4.0*.

The complete success of the integration of the Internet of Things will be dependent on the capacity of development and the organization of the various technologies. This work will have as a consequence the natural integration of all associated items like the sensors, actuators, among all the others. This requires an efficient use of the technologies considered. It's possible to group them in to three main groups: technologies that will empower the things to acquire contextual information, other that process the contextual information gained and those will enable the security and privacy of this same information gained. It is possible to group the first two in a functional block, whose main function is to support the intelligent interconnection between the various things integrated, which basically ends up being what differentiates the Internet of Things in the future from the Internet of today. The other block is not functional, but a mandatory requirement, without which, the assimilation and acceptance by all the interested parties will be severely impacted if not guaranteed (Vermesan, 2013).

For a possible general understanding of some of the technologies involved in the integration of the Internet of Things and Cyber-Physical Systems, it will be described below a generalized explanation of their potential and current limitations for a better understanding of the topic in question.



Source: (Postscapes, 2013)

Figure 55. Technologies integration (source: Postscapes, 2013).

Communication Technologies

The technologies with transmission capacity for distance applications, designated by Wireless Power Transmission or simply WPT, are classified as simple as short, medium and long-distance. These being defined by its frequency band where they operate and the main principle of operation used. In this context, it is possible to describe the short-distance as normally using inductive magnetic coupling to Low Frequency designated by LF, or High Frequency designated by HF and allow the transmission up to a few centimeters. The applications of transmission distance media using an Ultra High Frequency and are known for UHF, in which are used passive transponders placed in typical distances of 10 meters in spite of already being in research and development technologies for the transmission of data involved in lasers and microwave operation that should allow accomplish great distances in the future.

Another factor that influences the capacity for data transmission is its operational work environment, located in the most diverse existing materials that may disrupt or even inhibit their ability to transmit or maneuvering the data required.

In the case of materials not conductors of electricity, its insulating influence through their relative electrical permittivity, can degrade the propagation of the field by introducing failures in transmission. However, the conductive materials of electric energy are usually more problematic for the wireless systems because it often acts under electromagnetic interference alternating magnetic fields that cause eddy currents program in the material, which will create opposite magnetic fields to the desired. These making impossible in some cases the transmission of information and leading also to a heat not desired of the material resulting in a consequent loss of energy (Mayordomo et al., 2013).

Near Field Communication System

Near Field Communications System or NFC, is a technology that uses radio frequencies to transmit data and normally operates in a frequency band of 13.56 MHz's. Until this moment, it is not required licenses for use on this frequency band by which its use remains free and deregulated, but using a communication protocol.

A device that uses this technology, need to be in range of another in a short distance because it develops through a process in which an initiator sends waves for a target need to connect to. This allows the use of receptors target without the need of having batteries coupled in communication, only needed from NFC Peer-to-Peer networking because the

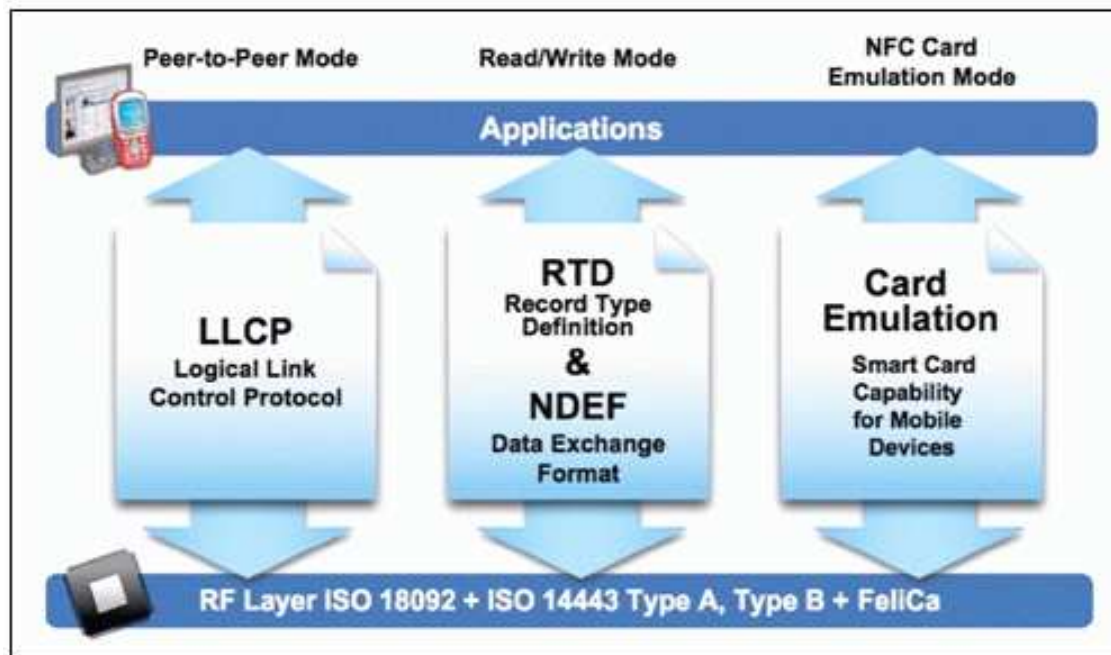

Source: (NFC Forum, 2013)

Figure 56. NFC Communication Modes (source: NFC Frum, 2013).

initiator generates a field of radio frequency that can provide sufficient power to wiring harnesses needed to connect to target to communicate. This allows achieving ratios of data transmission in the order of 106.212 or 424 kbps, generally dependent on the requirements and operating environment surrounding.

It is possible two environments of communication in this system. One is the active mode in which both the communication apparatus generate it owns radio signal frequency with data. Another is the passive mode where only the appliance initiator generates the broadcast signal and the target tool shapes the information back to the initiator of the original signal. However, it may be submitted three modes of communication: those from NFC Reader or Writer where the data are transmitted in a message format that is not secure, NFC Card Emulation where data are transmitted with a behavior of a Smartcard secure and finally the NFC Peer-to-Peer where the data are transmitted by connection protocol between apparatus appliances (Vermaas, 2013). Already there is standardization currently accepted by some organizations such as ISO, ECMA and ETSI (Tamura, 2013). Are being implemented in various Smartcards, Smartphone among others and even for use in services for payment and identification as access control, consumer electronics, health care, transport, payments among others (Wachs, 2013).

Radio Frequency Identification Systems

This system also uses the energy produced by the magnetic field to emit an electromagnetic signal in order to be able to exchange information between the RFID Tag and its Reader. This system is generally composed of a Reader, who send these signals and receives back the response issued by the Tag with unique information contained. Due to the standardization already existing afforded by the International Organization for Standardization or ISO and Electronic Product Code or EPC, makes it possible to run this operation getting the reading of multiple tags. Uses a single code as a URL, where the entire Electronic Product Code number can be used as identification in a database to identify a single product (Burlington, 2009).

Can be considered the classification of tags in three states: active tag with its own energy source that allows to generate and issue the identification signal; the semi-active tag, despite using an own supply of energy to activate its circuit does not uses to send the identification signal; the passive tag without any type of own energy and uses the energy provided by reader to send the signal (Sangkil et al., 2013).

The operational capability of this system has undergone a rapid evolution due to the current development of Radio Frequency Integrated Circuits and antennas. These making them ever more economical manufacture and consequent use with the development of manufacturing technologies and the simplicity of its architecture for operation where it becomes popular in typical applications of systems of this level of the area of the identification and traceability of objects (Kim et al. , 2013).

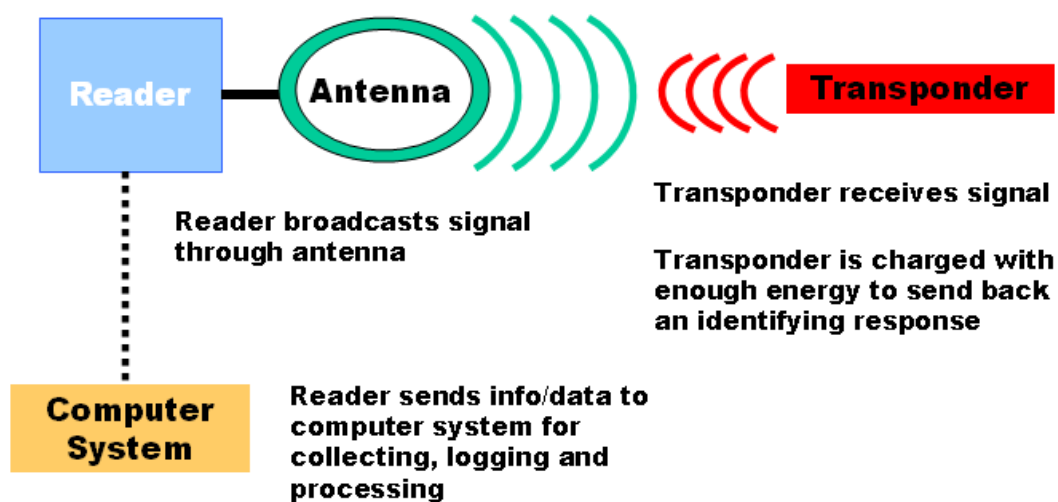

Source: (Saarathi, 2012)

Figure 57. RFID Communication system (source: Saarathi, 2012).

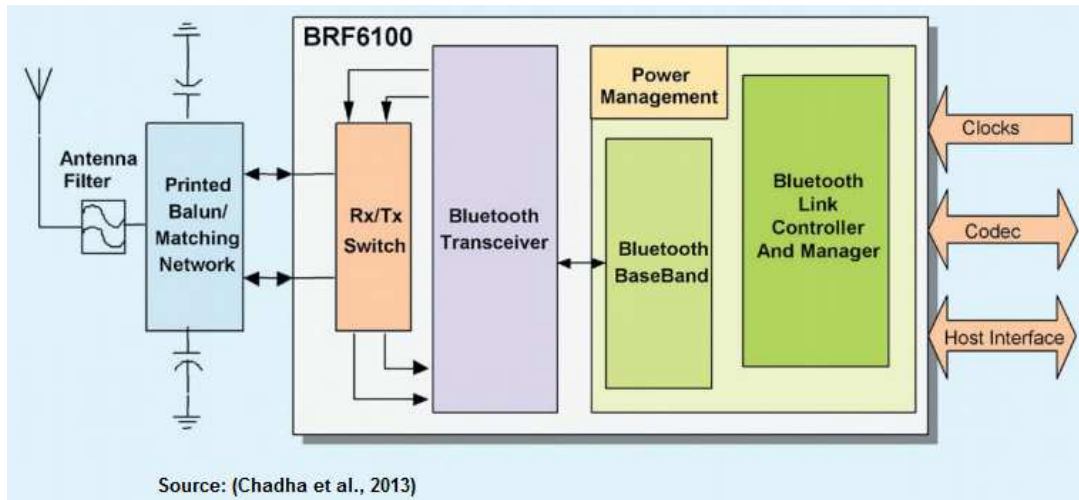

Figure 58. Bluetooth device configuration (source: Chadha et al., 2013).

Bluetooth Systems

The Bluetooth system is based on a technology for the transmission of radio waves at a frequency of 2.4 GHz, but using a technique called frequency hopping. This allows minimizing the potential interference from other networks that are operating in the same frequency band. This system offers three classes of range transmission and is defined in devices allowing managing different distances (Kushwaha, 2013). Its use is related to the level of control and communication for data transfer in mode wirelessly between devices, in places where it is desirable to use low bandwidth and a low cost of deployment (Chadha et al., 2013). New development such as the Bluetooth LowEnergy allows it to be up to 15 times more efficiently in the management of energy consumption.

ANT System

The ANT system uses the radio frequency waves solution through a proprietary protocol operating in the industrial sector, scientific and medical band, 2.4 GHz, to transmit signals, data, endorsements and detection of errors. This allows three types of messages: Broadcast messaging, through a track of single one way communication from one node to the receiving node without return of information; acknowledged messaging, where the transmitter is informed of the success or failure of the transmission, but without the possibility of retransmission; finally the third burst transmission technique where it is possible to use the entire band where and when it is necessary to ensure the integrity of transmitted data (Smith, 2011).

This is an ultra low power consumption efficient management system in network applications. In a simple and efficient way can ultimately maximize the time of use of energy of support systems with capacity of nodes and being able to act as transmitters, receivers or transceivers to route traffic to other nodes. However, it should be noted that this system has a lack of interoperability with the other due to the use of a proprietary protocol (Buratti et al., 2009).

Wi-Fi System

The system of network Wi-Fi use the emission of radio waves by means of antennas to create magnetic fields of sign up access points to provide communication and transmission of data in a quick way that the devices can detect and tune. Often wrongly designated by Wireless Fidelity, the acronym Wi-Fi only represents the trademarked term of company W-FI Alliance to designate a Wireless Local Area Network or WLAN, based on the Institute of Electrical and Electronics Engineers 802.11 standards (Wi-Fi Alliance, 2013).

Wi-Fi is a technology that allows an electronic device to exchange data wirelessly (using radio waves) over a computer network, including high-speed Internet connections. The Wi-Fi Alliance defines Wi-Fi to any "wireless local area network (WLAN) products that are based on the Institute of Electrical and Electronics Engineers' (IEEE) 802.11 standards".

ZigBee System

This system is geared primarily for wireless personal area networks applications as systems of heating, lighting, fire and intrusion detection, ventilation and air conditioning among others, being compatible with the majority of the technologies in use and the ability to manage up to 255 devices on a single network (Kinney, 2003).

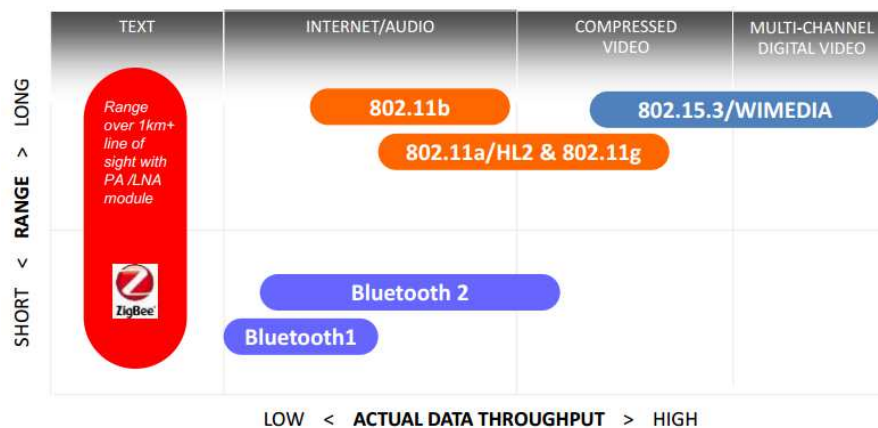

Source: (ZigBee, 2012)

Figure 59. Wireless Network Technology (source: ZigBee, 2012).

With a capacity for self-healing mesh networking, allows the nodes may find new routes through the network whenever there is a failure on the route of action. The ZigBee IP is the first open standard and is an IPv6-based full wireless mesh networking solution (ZigBee Alliance, 2011).

Z-Wave System

This system uses a protocol based on low powered communications technology via Radio Frequency. Was designed for the control, monitoring of applications in residential and commercial and significantly interoperable wireless supporting full mesh networks without the need for a coordinator node. The band of action is the sub-1GHz in which there is no risk of interference from other systems, this being an important advantage (Z-Wave Alliance, 20012). However, this band is limited by European regulations for operability up to 1 %, which for this system, allows the management of the majority of their applications, with the possibility of creating mesh up to 232 nodes (Buratti et al., 2009).

6LowPAN

The organism known by Internet Engineering Task Force, runs in 2007 an open standard called 6LoWPAN. This allowing the use of protocol IPv6 standard over 802.15.4 layers at low power, data rate, cost in personal area networks with the ability to use Simple Network Management Protocol (Buratti et al. , 2009). This have the ability to communicate with other devices through the interoperation between the IPs allowed through defined encapsulation and header compression mechanisms that allow IPv6 packets to be sent to and received from over IEEE 802.15.4 based networks (Smith, 2011).

Its main advantages are located in its popularity, easily application and available space for address, support stateless address in auto-configuration of easy and affordable way, allowing an appreciable expansion (Ma et Luo, 2008).

WiMAX System

This system is based in the IEEE 802.16 standard, having the ability to cover several amplitudes of different frequencies in a converged solution for single band radio emission by providing flexible network architecture in order to withstand high ratios of data transmission due to profile based on Orthogonal Frequency Division Multiple Access Server.

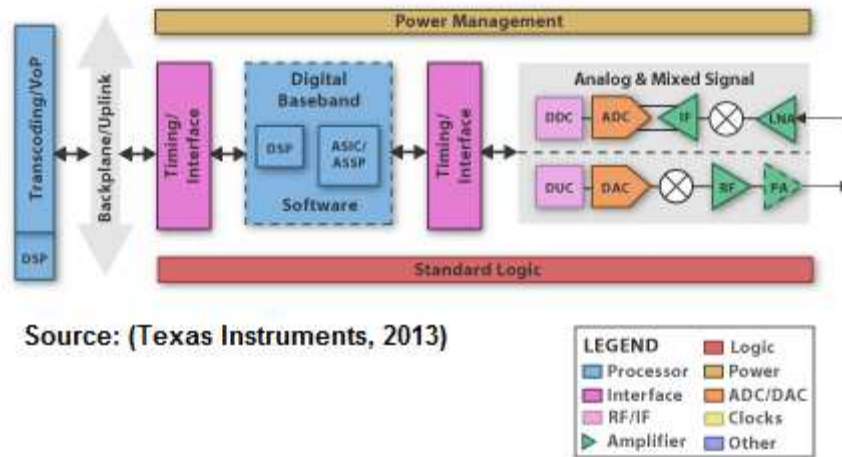

Figure 60. WiMAX & Wireless Infrastructure Equipment Block Diagram (source: Texas Instruments, 2013).

Using an antenna that allows downlink and uplink in Multiple-Input and Multiple-Output way as well also beam forming, along with flexible sub-channelization schemes and Advanced Coding and Modulation. This system also supports tolerance to Multipath and Self-interference, Scalable Channel Bandwidth, Frequency Reuse and Error Correction Techniques (Burnette, 2009).

WirelessHART System

This protocol was developed especially for operations in industrial environment. Have an architecture for five levels: physical, data link, network, transport and application (Dalssoto, 2013).

The Utilization of band emission at 2.4 GHz in the transmission of data, their Field Devices have the ability to also monitor, store a certain number of data which allow then transmit under certain conditions. They are part of this system the adapters whose function is the integration of network HART on wireless system where Routers are the bridge of connection with the network of automation for that can be analyzed and managed throughout the system information. There are also Access Points where the access to the wireless network is allowed for the Network Manager and the Security Manager. These may have available access points for a communication with the field devices or Handheld Devices that allow a control of perform maintenance on the network, the well the installation and control of network devices.

Appendix II

The SmartFactory^{KL} Vision Research Case Study

The Internet of Things, by means of information and communication technology, will enable to integrate the Cyber-Physical Systems through single architecture for data transmission between themselves. These would allow the most diverse components and systems being interconnected in a perfect synergy and harmony in which will be with autonomy to perform tasks independent of contextual form self sustained, flexible and capable of adapting to ever more complex tasks.

In 2005, in Kaiserslautern, a group of companies (BASF AG, DFKI GmbH, KSB AG, Pepperl, Fuchs GmbH, ProMinent GmbH, TU Kaiserslautern and Siemens AG) founded the project SmartFactory^{KL}. These had as its intention to prepare the development of integration of technologies in an industrial looming toward the Four Industrial Revolution, through a vision where they could integrate the technologies of information and communication with the productive physical systems for the development of an industrial intelligent environment. This way they could bring the real world melting the physical with digital world.

Some requirements are present in the development of the architecture of research: the integration of equipment through the technology of principle Plug & Play for a more simple and rapid integration into a productive environment; through holistic view of production planning and control; and also reducing the effort of integration necessary for upgrades of industrial automation systems through a uniform communication model based on a Service Oriented Architecture.



Source: (DFKI, 2013)

Figure 61. SmartFactory^{KL} Vision Research Case Study Living Lab (source: DFKI, 2013).

Manage the huge amount of data and information provided by all these sensors and interconnected components present in this type of industrial organization, will be an essential condition for effective management in the industry. The concern is providing semantic context annotation based data of production in order to increase efficiency in the management of the process and decision making. The information can be screened and provided contextually as well as the use of semantic technologies. The growing philosophy complexity in the future can be controlled by means of a filtering and analysis effective in the control of information flood is handling complex task in the use of a correct architecture is the use of spatial context information in factory systems to optimize mobile and adaptive processes. However, the human being will continue to be the sore point of decision-making ever more complex tasks by which it will be necessary to develop interfaces capable of supporting the user through the search for principles Model Based User Interface Development used in science informatics adapted for automation technology. Also, as a formalization and integration of usability-norms in the use where development process, which would allow an intuitive use and secure with the fields devices in an ubiquitous industrial environment on the basis of task-oriented knowledge models lead to controllability of complex technical systems.

The Production Model

The production model is located in German Research Center for Artificial Intelligence (DFKI), based on a highly customized production with production capacity to low quantities but, presenting the possibility of a high range of varieties of product to be manufactured. This way their requirements can be met due to a high flexibility of the system in which it is possible a customization of product in the batch size one to customer specification. Also, all their functional components are from various different manufacturers, but are all working on a single network, through the various levels of communication to form wireless in a simple structure and able to be updated.



Source: (DFKI, 2013)

Figure 62. SmartFactory^{KL} Vision Research technology integration (source: DFKI, 2013).

Robotic Order Picking Station

In this model, the product has contained all the necessary information on its semantic memory in the whole life cycle, by means of a Radio Frequency IDentification chip where it uses an Object Memory Model for the representation of information. Thus, the production process must start at the station assignment where a central control emits the requirements necessary production for the satisfaction of the production order through parameters of specific production. This way to be able to be transmitted to the various operational components present in the system of production constituting a vertical and horizontal integration of information through the different systems present, being registered and updated throughout the moment all the stages of the process on the product memory. In this model, the robot acts as a connecting element between storage, milling machine and automated assembly.

Model Milling Station

This model use the Computer Numerical Control 3-axis milling machine with a pneumatic bench vice and the fully automated loading through the robot arm, and is to be managed by means of an industrial computer. This controls all its activity in which information for production through the milling program is included in RFID tag embedded in the product.

Model Automated Assembly Station

After completing the milling process the parts of the product in production, it follows the assemble through a unit Pick & Place in which will be assembled by different influence pneumatic and electronically driven units. These according to the information of the customer's requirements stored in digital memory inserted in the product, which triggers the information on which the mounting medium on the circuit will be enabled to perform the task as the requirements embedded in each order custom product to produce.

Model Manual Working Station

The model presents a station of human intervention for that might be the target of a management at the level of quality control or product activation. Here, the operator by means of information and communication technologies and using an interface for easy visualizing can enable rapid analysis, decision-making and subsequent submissions of instructions.

Model Route Guidance Service Building Technicians

Any industrial unit needs to ensure the maintenance services so that your process of creating added value can be the most efficient possible. In this model, the convergence of a mobile maintenance through a positioning, communication and integration of technologies into service allows a real-time interaction with the operator at any point in the process.



Source: (DFKI, 2013)



Source: (DFKI, 2013)

Figure 61. SmartFactory^{KL} Vision Research maintenance service (source: DFKI, 2013).