

Application of Wetland Systems in the Treatment of Acid Rock Mine Drainage

Diogo Cunha Conde Pinho

**Master Degree in Chemical Engineering
Branch of Environmental Protection Technologies
October 2010**

Title: Application of Wetland Systems in the Treatment of Acid Rock Mine Drainage

Thesis Author: Diogo Cunha Conde Pinho

Thesis Supervisor Portugal: Prof. Susana R. Sousa

Chemical Engineering Department, Instituto Superior de Engenharia do Porto

Thesis Supervisor Czech Republic: Prof. Miroslav Černík

Technical University of Liberec

Location: Project Developed in Aquatest Company

Acknowledgments

I would especially like to thank Ing. Libor Polach, for his guidance and patience throughout my training practice. Ing. Irena Šupikova for her guidance, technical support in this work and patience. Mgr. Kamil Nešetřil the help on the Geochemist's Workbench Software. Prof. Miroslav Černík for the technical suggestions in the thesis contents and especially for giving me this opportunity to work in this project. Ing. Adriana Laputková for her technical advice in the adjustment of text form. Prof. Susana Sousa all the support, motivation and guidance with the thesis structure. Prof. Helder Chaminé and Prof. M^a José Afonso for their encouragement and support in the modelling section. I also want to thank Aquatest a.s. the opportunity to be a part of the company.

Abstract

The presented work was conducted within the Dissertation / Internship, branch of Environmental Protection Technology, associated to the Master thesis in Chemical Engineering by the Instituto Superior de Engenharia do Porto and it was developed in the Aquatest a.s, headquartered in Prague, in Czech Republic.

The ore mining exploitation in the Czech Republic began in the thirteenth century, and has been extended until the twentieth century, being now evident the consequences of the intensive extraction which includes contamination of soil and sub-soil by high concentrations of heavy metals.

The mountain region of Zlaté Hory was chosen for the implementation of the remediation project, which consisted in the construction of three cells (tanks), the first to raise the pH, the second for the sedimentation of the formed precipitates and a third to increase the process efficiency in order to reduce high concentrations of metals, with special emphasis on iron, manganese and sulfates.

This project was initiated in 2005, being pioneer in this country and is still ongoing due to the complex chemical and biological phenomenon's inherent to the system. At the site where the project was implemented, there is a natural lagoon, thereby enabling a comparative study of the two systems (natural and artificial) regarding the efficiency of both in the reduction/removal of the referred pollutants.

The study aimed to assist and cooperate in the ongoing investigation at the company Aquatest, in terms of field work conducted in Zlaté Hory and in terms of research methodologies used in it. Thereby, it was carried out a survey and analysis of available data from 2005 to 2008, being complemented by the treatment of new data from 2009 to 2010. Moreover, a theoretical study of the chemical and biological processes that occurs in both systems was performed. Regarding the field work, an active participation in the collection and *in situ* sample analyzing of water and soil from the natural pond has been attained, with the supervision of Engineer, Irena Šupiková. Laboratory analysis of water and soil were carried out by laboratory technicians.

It was found that the natural lagoon is more efficient in reducing iron and manganese, being obtained removal percentages of 100%. The artificial lagoon had a removal percentage of 90% and 33% for iron and manganese respectively. Despite the minor efficiency of the constructed wetland, it must be pointed out that this system was designed for the treatment and consequent reduction of iron. In this context, it can conclude that the main goal has been achieved.

In the case of sulphates, the removal optimization is yet a goal to be achieved not only in the Czech Republic but also in other places where this type of contamination persists. In fact, in

the natural lagoon and in the constructed wetland, removal efficiencies of 45% and 7% were obtained respectively.

It has been speculated that the water at the entrance of both systems has different sources. The analysis of the collected data shows at the entrance of the natural pond, a concentration of 4.6 mg/L of total iron, 14.6 mg/L of manganese and 951 mg/L of sulphates. In the artificial pond, the concentrations are 27.7 mg/L, 8.1 mg/L and 382 mg/L respectively for iron, manganese and sulphates.

During 2010 the investigation has been expanded. The study of soil samples has started in order to observe and evaluate the contribution of bacteria in the removal of heavy metals being in its early phase.

Summarizing, this technology has revealed to be an interesting solution, since in addition to substantially reduce the mentioned contaminants, mostly iron, it combines the low cost of implementation with an reduced maintenance, and it can also be installed in recreation parks, providing habitats for plants and birds.

Key words: Acid mine drainage, mining impacts, passive system, heavy metals, Zlaté Hory.

Resumo

O trabalho que se apresenta foi realizado no âmbito da disciplina de Dissertação/Estágio do ramo de Tecnologias de Protecção Ambiental, do Mestrado em Engenharia Química do Instituto Superior de Engenharia do Porto tendo sido desenvolvido na empresa Aquatest a.s., sediada na cidade de Praga, na República Checa.

A exploração de minério na República Checa teve início no século XIII, tendo-se prolongado até ao século XX, sendo actualmente evidentes as consequências da extracção intensiva nomeadamente a contaminação do solo e sub-solo por concentrações elevadas de metais pesados.

A região montanhosa de Zlaté Hory foi o local escolhido para a implementação de um projecto de remediação, que consistiu na construção de três células (tanques), a primeira para aumentar o pH, a segunda para a sedimentação dos precipitados formados e uma terceira para aumentar a eficiência do processo, de modo a reduzir as elevadas concentrações de metais, com especial ênfase para o ferro, manganês e sulfatos.

Este projecto foi iniciado em 2005, sendo pioneiro na República Checa, encontrando-se ainda em curso devido à complexidade dos fenómenos químicos e biológicos inerentes a este tipo de sistemas. No local onde foi implementado o projecto, existe uma lagoa natural possibilitando assim, uma análise comparativa dos dois sistemas (natural e artificial) ao nível da eficiência de ambos na redução/remoção dos referidos poluentes.

O presente trabalho teve como objectivo auxiliar e colaborar na investigação em curso na empresa Aquatest, quer ao nível do trabalho de campo desenvolvido em Zlaté Hory, quer ao nível da pesquisa de metodologias utilizadas no mesmo. Assim, efectuou-se um levantamento e análise dos dados disponíveis desde 2005 até 2008, sendo complementados pelo tratamento de novos dados referentes ao período entre 2009 e 2010. Além disso, fez-se um estudo teórico dos processos químicos e biológicos desencadeados em ambos os sistemas. No que diz respeito ao trabalho de campo, houve uma participação activa na recolha e análise de amostras de água e de solo *in-situ* da lagoa natural, com a supervisão da Eng^a, Irena Šupiková. No entanto, as análises laboratoriais da água e do solo foram efectuadas pelos técnicos do laboratório.

Verificou-se que a lagoa natural é mais eficiente na redução do ferro e manganês, tendo sido obtidas percentagens de remoção de 100%, contrastando com os 90% e os 33% para o ferro e o manganês respectivamente, na lagoa artificial. Apesar da eficiência do sistema artificial ser menor, é necessário salientar que este foi concebido principalmente, para o tratamento e consequente redução do ferro. Neste contexto, pode-se concluir que o objectivo primordial foi alcançado.

No caso dos sulfatos, a optimização da sua remoção é um objectivo ainda por alcançar, não só na República Checa, como também em outros locais onde existe este tipo de

contaminação. De facto, no caso da lagoa natural obteve-se uma eficácia de remoção de 45% e na lagoa artificial de apenas 7%.

Existe a possibilidade de a água à entrada de ambas as lagoas terem diferente proveniência. A análise dos dados recolhidos mostra, à entrada da lagoa natural, uma concentração de 4,6 mg/L de ferro total, 14,6 mg/L de manganês e 951 mg/L de sulfatos. No caso da lagoa artificial, as concentrações são de 27,7 mg/L, 8,1 mg/L e 382 mg/L respectivamente para o ferro total, manganês e sulfatos.

No decorrer de 2010 a investigação foi alargada, tendo-se iniciado o estudo de amostras de solo, com o objectivo de estudar e avaliar o contributo de bactérias na remoção de metais pesados, encontrando-se numa fase de recolha de dados.

Em suma, esta tecnologia revelou-se uma solução bastante interessante, dado que, para além de reduzir substancialmente os contaminantes já referidos, nomeadamente o ferro, alia o baixo custo de implementação a uma manutenção reduzida, podendo ainda ser utilizada para fins recreativos, exemplo da criação de parques lúdicos, para os quais poderá propiciar habitats para plantas e aves.

Palavras chave: Drenagem ácida de minas, impactos da actividade mineira, sistemas passivos, metais pesados, Zlaté Hory.

Contents

Abstract	III
Resumo	V
Index of Figures	IX
Index of Tables	XI
List of Abbreviations	XII
Chapter 1: Introduction	1
1.1 Environmental Impacts of Mining	1
1.1.1 Mine Wastes	1
1.1.2 Direct Impacts in the Soil, Surface and Ground Water	3
1.1.2.1 Soil	3
1.1.2.2 Surface Water	4
1.1.2.3 Ground Water	5
1.1.3 Acid Mine Drainage	5
1.1.3.1 Acid Mine Drainage Chemistry	5
1.2 Treatment of Acid Mine Drainage	7
1.2.1 Active Treatment	7
1.2.2 Passive Treatment	8
1.2.2.1 Aerobic Passive Treatment Types	9
1.2.2.2 Anaerobic Passive Treatment Types	11
1.3 Zlaté Hory	15
1.3.1 Mining Activity in Zlaté Hory	15
1.3.2 Geological Profile	17
1.3.2.1 Natural Conditions	17
1.3.2.2 Geological Conditions	17
1.3.3 Acid Mine Drainage – Basic Characteristics	20
1.4 Treatment System Applied in Zlaté Hory	22
1.4.1 Natural Wetland	22
1.4.2 Constructed Wetland	24

Chapter 2: Materials and Methods	29
2.1 Field Measurements	29
2.2 Laboratory Analysis	30
Chapter 3: Results and Discussion	31
3.1 Natural Wetland	31
3.1.1 Long Term Observation of Profiles and Outflow	32
3.1.1.1 Iron Removal Rates	33
3.1.1.2 Manganese Removal Rates	34
3.1.1.3 Sulphate Removal Rates	35
3.1.1.4 Comparison Between Previous and Current Study	38
3.1.2 New Observation Points Installed in 2010	38
3.1.3 Wetland Processes	40
3.1.3.1 pH variation profile	41
3.1.3.2 Metal Removal Processes	41
3.1.4 Modelling of Profiles	46
3.2 Constructed Wetland	49
3.2.1 Long Term Observation of Outflow	50
3.2.1.1 Iron Removal Rates	51
3.2.1.2 Manganese Removal Rates	52
3.2.1.3 Sulphate Removal Rates	53
3.2.1.4 Seasonal Variations	54
3.2.2 Comparison Between the Natural and the Constructed Wetland	56
Chapter 4: Conclusions and Future Work	57
4.1 Conclusions	57
4.2 Future Work	58
References	59
Appendix A	63
Appendix B	65
Appendix C	67

Index of Figures

Figure 1.1 - Contaminated surface in Zlaté Hory by Fe ³⁺ hydroxide	2
Figure 1.2 - Construction example of an Upstream Tailing Dam	3
Figure 1.3 - Erosion of Waste Rock Dump	3
Figure 1.4a - Subsidence cause by dewatering	4
Figure 1.4b - Cross section at higher magnification of subsidence	4
Figure 1.5 - Available Acid Mine Drainage remediation options	7
Figure 1.6 - Cross section of an Aerobic Wetland	10
Figure 1.7 - Cross section of an Open Limestone Channel	10
Figure 1.8a - Cross section of an Anaerobic Wetland	11
Figure 1.8b - Diagram of an Anaerobic System	11
Figure 1.9 - Cross section of an Anoxic Limestone Drain	13
Figure 1.10 - Cross section of a RAPS System	14
Figure 1.11 - Geographic location of Zlaté Hory	15
Figure 1.12 - Open pit at Zlaté Hory mining site in 1990	16
Figure 1.13 – The last car of ore mined in the 17 th December 1993	17
Figure 1.14 - Examples of minerals present in Zlaté Hory	18
Figure 1.15 – Pilot and natural treatment plant in Zlaté Hory	21
Figure 1.16 - Contaminated flow from shaft P3C	23
Figure 1.17 - Excavated ditch	23
Figure 1.18 - Main output	23
Figure 1.19 - Aerial view of the Zlaté Hory treatment facility	24
Figure 1.20 - Constructed wetland input (P3C)	25
Figure 1.21 - RAPS pond covered with plastic foil	25
Figure 1.22 - Organic layer in the RAPS system	26
Figure 1.23 - Drainage pipe	26
Figure 1.24a - Sedimentation pond	27
Figure 1.24b - Set of four drainage pipes	27
Figure 1.25 - Wetland basin	27
Figure 1.26 - Constructed wetland output	27
Figure 3.1 - Organic matter present in the natural wetland	31
Figure 3.2 - Wetland zones covered by iron hydroxides	31
Figure 3.3 - Average pH evolution over time along the natural wetland profile	32
Figure 3.4 – Evolution of Fe removal over time in the natural wetland	33
Figure 3.5 - Fe removal (%) along the natural wetland profile	34
Figure 3.6 – Evolution of Mn removal over time in the natural wetland	35
Figure 3.7 - Mn removal (%) along the natural wetland profile	35
Figure 3.8 – Evolution of sulphate removal over time in the natural wetland	36

Figure 3.9 - Conductivity dependence on $[\text{SO}_4^{2-}]$	36
Figure 3.10 - Sulphate removal (%) along the natural wetland profile	37
Figure 3.11 - Scheme of new studies performed in Zlaté Hory's wetland	39
Figure 3.12 - HCO_3^- , CO_2 and pH dynamics along the wetland profile	41
Figure 3.13 - Differences on plant growth during the growing season	45
Figure 3.14 - Model of flow direction in the natural wetland	46
Figure 3.15 - Water characteristics at P4	47
Figure 3.16 - pH evolution according to reaction progress	48
Figure 3.17 - ORP dynamics along the wetland profile	48
Figure 3.18 - Fe^{2+} and Mn^{2+} evolution along the wetland longitudinal profile	49
Figure 3.19 - Description of sampling points in the constructed wetland	50
Figure 3.20 - Average pH evolution over time along the constructed wetland	50
Figure 3.21 - Evolution of Fe removal over time in the constructed wetland	51
Figure 3.22 - Fe removal (%) along the constructed wetland cells	52
Figure 3.23 - Evolution of Mn removal over time in the constructed wetland	53
Figure 3.24 - Mn removal (%) along the constructed wetland cells	53
Figure 3.25 - Evolution of sulphate removal over time in the constructed wetland	54
Figure 3.26 - Sulphate removal (%) along the constructed wetland cells	54
Figure B.1 - Zlaté Hory site plant	66
Figure C.1 - Design criteria of remediation technologies based on the water parameters	68
Figure C.2 - Flowchart for passive treatment decision based on water chemistry and flow	68

Index of Tables

Table 1.1 - Differences between Waste Rock and Tailings	2
Table 1.2 - Acidic water characteristics from the natural wetland	20
Table 1.3 - Acidic water characteristics from the artificial wetland	21
Table 3.1 - Annual metal removal rates in tons per year	37
Table 3.2 - Compilation between 2005 – 2008 and 2007 – 2009 studies	38
Table 3.3 - Results of new performed studies	40
Table 3.4 - Seasonal variation in Fe and Fe ²⁺ removal rates	42
Table 3.5 - Seasonal variation in Manganese removal rates	43
Table 3.6 - Seasonal variation in Sulphate removal rates	45
Table 3.7 - Model water composition representing the initial conditions in the NW	47
Table 3.8 - Seasonal variations of all major pollutants	55
Table 3.9 - Comparison between the natural and the constructed wetland	56

Index of Abbreviations

ALD – anoxic limestone drains

AMD – acid mine drainage

ARD – acid rock drainage

DO – dissolved oxygen

L/s – liters per minute

mg/L – milligram per liter

OLC – open limestone channels

ORP – oxidation-reduction potential

PVC – polyvinyl chloride

RAPS – reducing and alkalinity producing systems

SRB – sulphate-reducing bacteria

TDS – total dissolved solids

1: Introduction

1.1 Environmental Impacts of Mining

Since mankind became aware of the metal value existing in the subsurface, the exploitation of these resources has led to establishment of mining sites throughout the world. During several decades even centuries, mining was one of the most important means of subsistence for a large population group world-wide, but with the developments in industry and science, this activity has almost completely stopped. Consequently, the majority of mines have been abandoned causing serious environmental problems to the surrounding sites. Alteration of site topography during the exploration time is also worth mentioning.

Mining activities are harmful to the environment and according to^[1] it has been estimated that more than 70% of all the material excavated in the mining operation world-wide is waste. This perspective has increased society's awareness as well as the efforts made by government agencies regarding more effective legislation for this activity. As a result, treatment of toxic metals from aqueous solution and wastewater effluents is the issue of primary importance.

Polymetallic ore exploration in Zlaté Hory ended in 1993 leaving a trail of severe effects on the site. In order to treat or remediate the site a new water treatment technique was implemented and studies have been carried out to understand how nature can be a part of the treatment itself.

In this chapter, a review of some potential hazards arising from mining activity and a comparison of the referred hazards and the present situation in Zlaté Hory will be presented.

1.1.1 Mine Wastes

Mine wastes are commonly classified according to their physical and chemical properties and according to their source. Physical and chemical characteristics of mining wastes vary according to their mineralogy and geochemistry, the type of mining equipment, the particle size of the mined material, and the moisture content^[2]. Impacts of mining are related to the mining itself, to the elimination of the residues from the mine, to the transportation of the mineral and to its processing, which frequently involves or produces hazardous substances^[3].

Mine wastes can generally be classified in two major categories, waste rock or spoil and tailings^[1]. Both contain significant concentrations of heavy metals and other contaminants and therefore may present an environmental problem. The distinction between these two types of wastes is made mostly by their grain size as shown in Table 1.1.

Table 1.1: Differences between Waste Rock and Tailings^[1].

Waste Rock	Tailings
Predominantly coarse-grained (1mm-50mm)	Predominantly fine-grained (<1mm)
Moderately reactive if sulfidic	Highly reactive if sulfidic
Moderate to high permeability en masse	Low permeability en masse
Generally tipped dry	Generally deposited from flowing water

These types of wastes can be used for backfilling mine workings or for reclamation and rehabilitation of mined areas^[2]. However, the problem arises when these wastes are dumped in the site near the excavated area submitted to weathering conditions. As a consequence of weathering, the metals in the direct contact with water will eventually dissolve causing Acid Mine Drainage (AMD) also referred to as Acid Rock Drainage (ARD). This subject will be discussed further in section 1.3.

Waste rock is disposed of in waste rock piles. Heaped waste is not homogenous, therefore bigger blocks will tumble to foot of slope and fine grained waste accumulates on the top of the slope. This generates shallow depressions on the top of the slope affecting site drainage, which causes potential hydrological problems, such as AMD due to leaching^[1].

The situation in Zlaté Hory is very similar to the one described above. Next to the mining area a waste rock pile was built and after the closure of the mine, the top of the pile was covered and revegetated. Nevertheless, drainage did occur and down below the heap (on the surface) it is possible to observe the so-called “yellow boy”, a yellow-orange solid caused by Fe^{3+} precipitation, as shown in Figure 1.1.

Figure 1.1: Contaminated surface in Zlaté Hory by Fe^{3+} hydroxide.

The disposal of tailings is made in sedimentation lagoons usually called “tailing dams” or “tailing dykes”. These lagoons are built of waste rock and the tailings themselves, constructed over time depending on the amount of waste available^[1]. It is possible to construct these tailings by three different methods: Downstream construction, Center-line construction and Upstream construction^[1]. Figure 1.2 shows an upstream tailing dam.

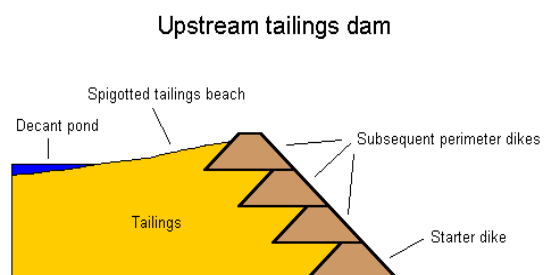

Figure 1.2: Construction example of an Upstream Tailing Dam^[4].

1.1.2 Direct Impacts in the Soil, Surface and Ground Water

1.1.2.1 Soil

The impact of mining on soils is mainly related to the excavation and stockpiling of the soil, changing the natural topography. This leads to surface subsidence with consequent disturbance in the land stability, deforming the natural conditions of mass rock^[5, 6]. In addition, erosion by concentrated water runoff, compaction and contamination by infiltrating runoff of leachate (see Figure 1.3) increases soil acidity^[7, 8].



Figure 1.3: Erosion of Waste Rock Dump^[9].

Weathering causes important changes in the stockpiles spreading the contaminants into the surrounding landscape. The small particles of heavy metals present on the top of the stockpile, that with time separate from the waste and are disseminated by the wind landing on the soil affecting its biodiversity^[3], is a great example. As the time lapses, the properties of the

stockpile soil deteriorate, decreasing the strength of the rocks and increasing soil porosity. This leads to loss of nutrients released by microbiological activity and the soil becomes biologically unproductive^[6, 8].

1.1.2.2 Surface Water

The mining effects on the surface and ground water are related. Nevertheless in Sections 1.2.2 and 1.2.3, a brief description of these effects will be given for both cases.

The impact of mining on the surface water environment is linked with the operational discharges of waters and dewatering during the active life of the mine, as well as after the closure of the mine, when dewatering ceases and water levels recover. In the first case, mineral processing operations and water pumping contribute to polluted runoff from the mine site into receiving watercourse. Mine water runoff has low pH and/or elevated concentrations of ecotoxic metals which causes serious ecosystem degradation^[1, 6, 10]. Moreover, dewatering can lead to subsidence and fractures on roof strata (see Figure 1.4a and 1.4b), causing severe impacts to surface morphology and hydrology, and major draining problems^[1].

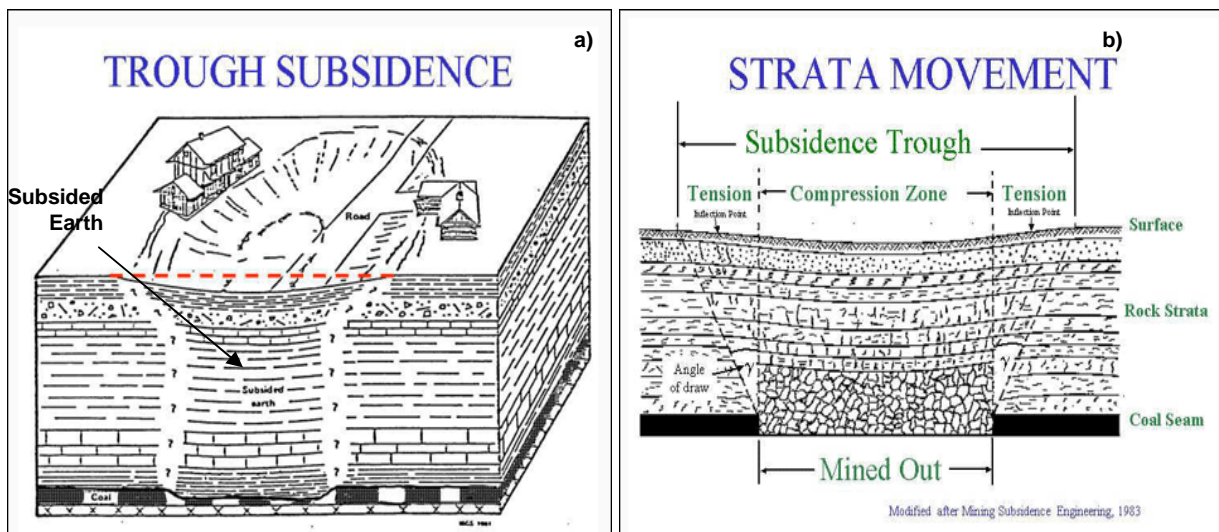

Figure 1.4: **a)** Subsidence cause by dewatering^[11]. **b)** Cross section at higher magnification of subsidence^[11].

With the flooding of an abandoned mine, the water table rises again and the dissolved acid salts, resulting from the pyrite oxidation, decrease the water pH and carry great concentrations of heavy metals polluting the surface water. In addition, the watercourse flow increases causing erosion and destroys the surrounding vegetation.

1.1.2.3 Ground Water

Contamination of ground water source may be caused by the drilling during the prospecting and mining process itself, where inadequate capping and sealing of the borehole and consequent infiltration of potentially contaminated surface water leads to chemical or biological contamination of ground water disrupting its hydrology^[6, 10].

As previously said, one of the major concerns of mining activity is dewatering, which plays an important role in this case. The lowering of water table can induce drainage into aquifers and more serious, subsidence or collapse of mine voids^[1, 6]. This happens when the aquifer below the mineral deposit is drained. Consequently, the water pressure will be reduced causing collapse of the mine void^[6].

1.1.3 Acid Mine Drainage

Acid Mine Drainage (AMD) is a persistent environmental problem caused by mining work and abandoned mine sites which lead to major water pollution.

As the mining engineering evolved, shafts have been built to drain the water into the rivers providing access to the lower levels and introduction of steam powered engines enabled water pumping from increasing depths lowering the ground water level. After the mine closure the water started to rise again and flooded the built shafts dissolving the rock containing minerals^[12]. The contact between these sulphide minerals, most common pyrite with water and oxygen and in the presence of oxidising bacteria, *Thiobacillus Ferrooxidans* cause acidic discharge^[13, 14]. The water quality derived from acidic drainage is worse soon after the closure of mine site, being improved as time passes but it will be perpetuated depending on the sulphite minerals availability, a process which can last for centuries^[13, 15].

The primary characteristics of AMD which are the matter of concern are the low pH values, high conductivity, high concentrations of iron, manganese and sulphates, and the presence of toxic heavy metals at trace levels^[16].

1.1.3.1 Acid Mine Drainage Chemistry^[1, 17, 18]

The generalised chemical reactions describing pyrite oxidation as a result of weathering processes are well known.

As previously said, the pyrite weathering causes oxidation of metal sulphide to sulphate releasing Fe^{2+} and acidity which is represented in the form of hydrogen ions (see equation 1.1).

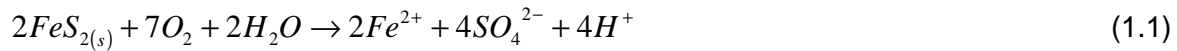

The second step is the oxidation of the Fe^{2+} to Fe^{3+} (see equation 1.2). If sufficient dissolved oxygen is present or due the oxygenation by contact with the atmosphere, the dissolved Fe^{2+} will be oxidized to Fe^{3+} consuming acidity. This reaction is pH dependent and may occur slowly at pH within 2-3 with no bacteria present or, on the other hand, the oxidation rate can be increased by bacteria but at higher pH values.

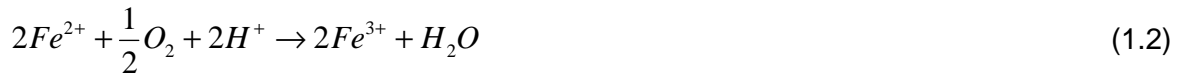

The hydrolysis of Fe^{3+} promotes formation of ferric hydroxide ($Fe(OH)_3$) and acidity (see equation 1.3). In this reaction, pH plays a very important role due to the fact that solids (precipitate) form if the pH is above 3.5.



Further, Fe^{3+} can react with pyrite to produce more acidity and Fe^{2+} (see equation 1.4), thereby perpetuating the cycle as Fe^{2+} is fed back into equation (1.2).

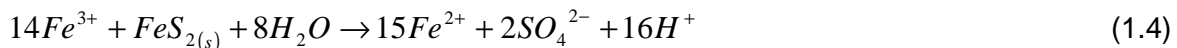

With this chain of reactions it is possible to understand that pyrite weathering combined with water and oxygen result in low pH values and high concentrations of metals. Furthermore, the iron hydroxide precipitate spreads, throughout the rivers, a rusting stream causing the depletion of benthic flora and degradation of fish habitat.

AMD can be remediated by abiotic (pure chemical) or biological processes (see Figure 1.5). In the following section an overview of these treatment options will be presented.

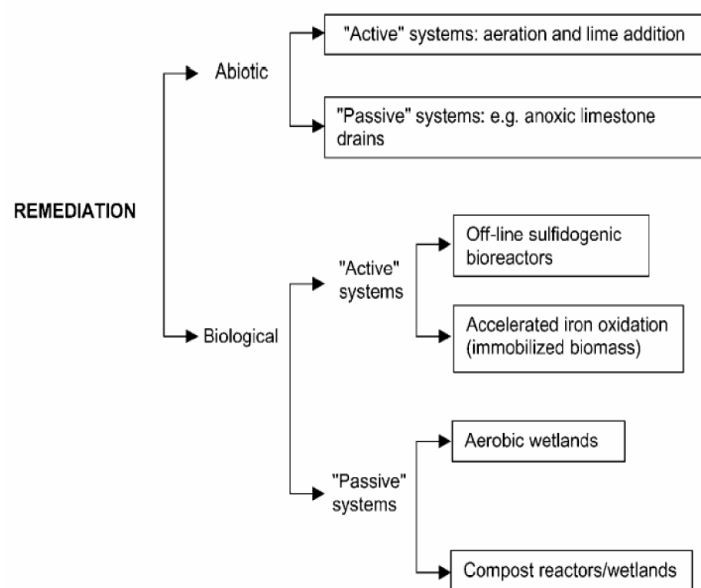

Figure 1.5: Available Acid Mine Drainage remediation options^[19].

1.2 Treatment of Acid Mine Drainage

1.2.1 Active Treatment

Active treatment can be set as conventional wastewater treatment applied to mine water^[1]. The most common approach to treat acidic mine discharge is by addition of alkaline materials such as calcium oxide, also known as quicklime, calcium carbonate, sodium hydroxide and sodium carbonate and magnesium oxide among others. The referred alkaline materials added to other chemicals help to neutralize AMD raising pH, and enhance metal precipitation as hydroxides and carbonates^[20-22]. As an example, quicklime (CaO) reacts with water to form calcium hydroxide as shown in equation 1.5. After hydrated lime dissolves, pH increases providing hydroxide ions which will precipitate metal ions as hydroxides, shown in equations 1.6 and 1.7^[20, 22].



Further in this process, the addition of organic polymers for coagulation and/or flocculation may be used to promote aggregation of precipitates^[1, 23]. The by-product produced from this treatment (shown above as example), is an iron hydroxide sludge which can contain various

other metals, depending on the chemistry of the mine water, being a hazardous waste due the potential release of contaminants through subsequent leaching^[21, 23]. Although the effective control on the release of acidic drainage, and their advantages over passive treatment in the process control which allows manipulation of this system depending on influent loading and discharge characteristics, it cannot be seen as an ideal long term solution, first due to the environmental concern from sludge disposal as has been said previously and the high operation costs of the process^[1, 12, 21]. For further and extensive description of active treatment processes see^[1] Chapter 4.

The state company DIAMO s. p. which is the Aquatest a.s.'s contractor (see Appendix A), installed a mine site in Zlaté Hory, apart from the pilot system a conventional water treatment system. The outputs of the pilot system and the natural wetland (see Chapter 1 Section 1.6), as well as, the water from the sludge bed drainage flow to a storage tank which is then, pumped to the treatment station. The inputs of the treatment station are those referred to above and groundwater from three mine floors. In the beginning of the treatment facility, two silos containing moisture of lime and water exist to produce $\text{Ca}(\text{OH})_2$, which is introduced to the water course flowing afterwards to the primary tank. Here chemical reactions between metals in solution and the chemical reagents start, and occur sedimentation of iron and manganese. pH is raised up to 9. Further in the tank, aeration is provided to oxidize the iron and manganese. The secondary tank is for sedimentation of iron and manganese. Finally, the treat water flows to a large settling pond enhancing the retention time, thereby allowing water to clarify. The treatment plant can be consulted in Appendix B.

1.2.2 Passive Treatment

Passive treatment is no more than, an improvement of water quality using only naturally-available energy sources, in the systems which require only infrequent maintenance in order to operate effectively over the entire system design life^[1]. Various numbers of studies have been performed throughout the world by research teams^[e.g. 1, 24] in order to improve potential efficiency of passive treatment since it is a relatively new type of treatment, with the purpose to optimize the contaminant removal, manipulating the environmental conditions using natural chemical and biological processes to reduce metal concentrations by precipitation and neutralize acidity in the incoming flow streams^[1]. Acid mine drainage is likely to contaminate the surrounding site for many decades after the mine closure, and therefore systems which require low-cost and low-maintenance such as this type are the most suitable to treat acidic discharge^[14].

Provided that the goal of this dissertation is to explore this type of methodology, some frequently-used techniques that are part of this type of treatment will be discussed in this

Section, and further in Section 1.6 of this chapter, an overview of the constructed and natural wetlands in Zlaté Hory will be given.

The treatment of AMD can be done using aerobic or anaerobic conditions. Aerobic passive treatment technologies include Aerobic Wetlands, Open Limestone Channels and Anaerobic passive treatment technologies such as Compost or Anaerobic Wetlands, Anoxic Limestone Drains or Reducing and Alkalinity Producing Systems (RAPS)^[25]. Depending on effluent characteristics or required/desired output discharges at a given site, it is possible to associate more than one type of technology^[18]. The site characterization and design criteria of the system is also an important specification to achieve better efficiency on the process as shown in Appendix C^[1, 18].

1.2.2.1 Aerobic Passive Treatment Types

→ Aerobic Wetlands

Aerobic wetlands consist of a pond with horizontal surface flow and its purpose is to aerate the water^[25-27]. Additionally, cattail rhizomes and other species from the area selected based on their ability to tolerate the quality of the incoming water may be planted on wetland soil^[24,27]. Although metal removal rates are similar for wetlands with and without plant growth, it can facilitate the filtration of particulates, prevent flow channelization, introduce organic material and provide wildlife benefits^[24, 27]. The net result of promoted mixed oxidation and hydrolysis reactions is a release of protons. To treat the mine drainage effectively, water should be net alkaline and contain low to moderate concentrations of metals, most common iron, manganese and aluminium^[1, 14, 25, 27].

An aerobic wetland design consists of a depth between 10 to 50 cm allowing rooted aquatic vegetation to grow (these species cannot tolerate depths of over 50 cm), enhancing the oxygenation and oxidizing reactions and metal precipitation while pH is maintained between 6 and 8 by bicarbonate buffering^[24, 25, 28]. Variations in water depth within the wetland may be beneficial for the system performance providing storage areas for precipitates, however it decreases vegetative diversity in the wetland based on what has been discussed previously^[25,26]. Figure 1.6 shows a cross section of an aerobic wetland.

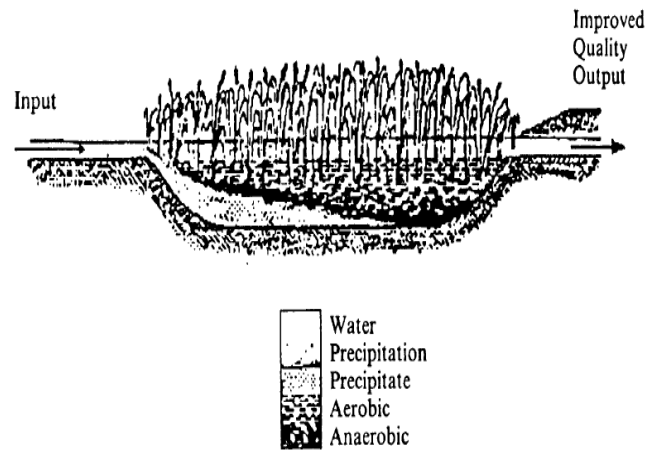

Figure 1.6: Cross section of an Aerobic Wetland^[14].

→ Open Limestone Channels

Open limestone channels (OLC) can be classified as one of the simplest passive treatment systems^[25, 26]. They can be built in two different ways; one consists of a constructed ditch with limestone where the acidic water will be directed to (see Figure 1.7), and the other method aims at introducing limestone directly to contaminated water flow^[24-26]. Both methods add alkalinity to the water by limestone dissolution and hence raising the pH^[25]. This system may be subjected to armoring by $\text{Fe}(\text{OH})_3$, thus reducing the alkalinity addition since limestone will eventually continue to dissolve but at slower rates^[24, 25]. To avoid limestone armoring the water flow can and should be increased generating more turbulence and keeping the precipitates in suspension^[25, 26]. Finally, these systems require a setting pond after the OLC to prevent watercourse contamination^[24].

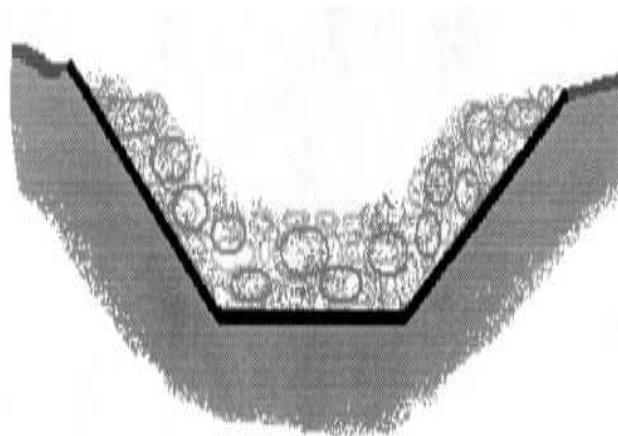

Figure 1.7: Cross section of an Open Limestone Channel^[25].

1.2.2.2 Anaerobic Passive Treatment Types

→ Anaerobic Wetlands

Anaerobic (or compost) wetland (see Figure 1.8a and 1.8b) are used to treat net acidic waters in the range of 300 to 500 mg/L with iron, aluminium and dissolved oxygen concentrations greater than 1 mg/L^[1, 14, 24, 27]. The general process is similar to aerobic wetlands but has the particularity to generate alkalinity through a combination of bacterial activity and limestone dissolution^[14,24]. To promote bacterial activity, conducted by sulphate-reducing bacteria (SRB), it is necessary to add a rich organic substrate, usually spent mushroom but can either be peat moss, wood chips or sawdust, to the wetland which allows anoxic conditions to develop^[14, 24, 25]. This process is based on the reverse of equation 1.1 (see Section 1.3.1). The compost removes the oxygen from the system developing the anoxic conditions and the microbial respiration within the organic layer reduce metals to sulphide form and consume H⁺, therefore acidity is lowered^[18, 25]. This reduced state prevents the coating and armoring of limestone^[27].

For wetland construction, limestone is placed at the bottom of the pond, 15 to 30 cm thick, above the layer of the organic substrate, 30 to 45 cm thick, and on the top water with 2.5 to 7.5 cm depth^[14, 24, 27]. Some literature^[24, 25, 27], encourages the use of plant growth to enhance available organic matter for bacterial activity as others, discourage due to the fact that they can oxygenate the substrate layer turning anoxic zones in micro-aerobic zones and affect the performance of the sulphate-reducing bacteria^[1, 14].

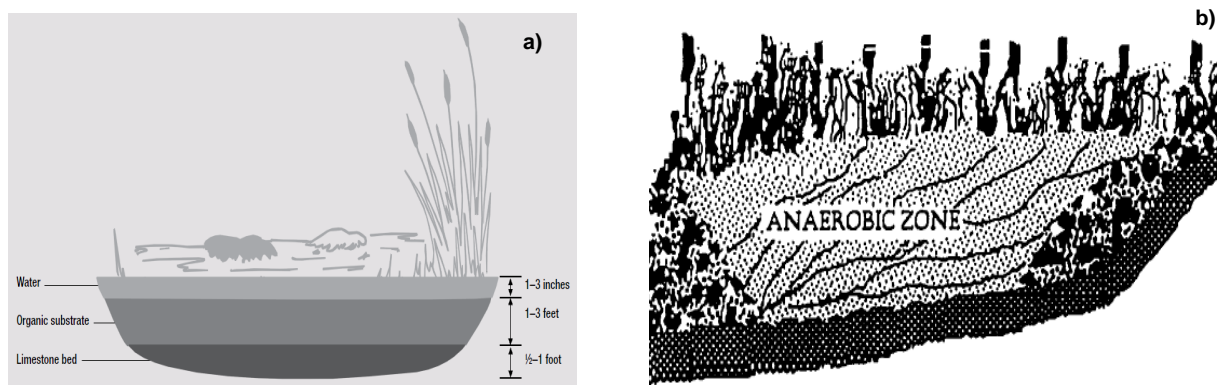

Figure 1.8: **a)** Cross section of an Anaerobic Wetland^[27] **b)** Diagram of an Anaerobic System^[14]

→ Anoxic Limestone Drains

Anoxic Limestone Drains (ALD) consists of a buried bed of limestone constructed to intercept acid mine drainage transforming the net acidic water in net alkaline water by the contact with the limestone in an anoxic closed environment (see Figure 1.9)^[24, 27]. According to the reviewed literature^[1, 14, 24, 27], this system is not suitable for treatment of all types of acidic water. Instead, in order to be effective, concentrations of Al^{3+} and Fe^{3+} (dissolved already in the incoming mine water) cannot be greater than 2 mg/L, concentration of dissolved oxygen less than 1 mg/L and the net acidic lower than 300 mg/L CaCO_3 . If the acidic water contains Fe^{3+} and Al^{3+} concentrations greater than previously said, the contact with limestone will form ferric hydroxide ($\text{Fe}(\text{OH})_3$) and aluminium hydroxide ($\text{Al}(\text{OH})_3$), filling the limestone pores and coating the limestone^[1, 14, 27]. As a consequence, limestone loses the capacity to dissolve metals and the formed precipitates can plug drain flow paths decreasing the limestone layer permeability^[14, 24, 27]. Concentration of dissolved oxygen greater than 1 mg/L promotes the oxidation of ferrous iron to ferric iron with the consequence which has been mentioned previously^[1, 24, 27]. Also, pH plays a very important role in this system because if the acidic water has pH less than 5 it can as well contain dissolved Al^{3+} and Fe^{3+} ^[24]. In feasible conditions, anoxic conditions are maintained throughout the process, thereby Fe^{2+} and Mn^{2+} will keep their reduced states, not precipitate as hydroxide or oxidize for further precipitation within the ALD system^[1]. Taking into account the operation characteristics of this system, it is suitable for AMD pre-treatment, before entering a constructed wetland or settling pond where metals will oxidize and settle to the bottom of the pond^[14, 24, 27].

Regarding its construction, the limestone is buried under several meters of clay and plastic is placed between the limestone layer and clay to prevent atmospheric oxygen input and enhance CO_2 accumulation^[14]. Retention times of 14 to 15 hours are used as standard practice to balance construction costs and efficiency of alkalinity generation^[25].

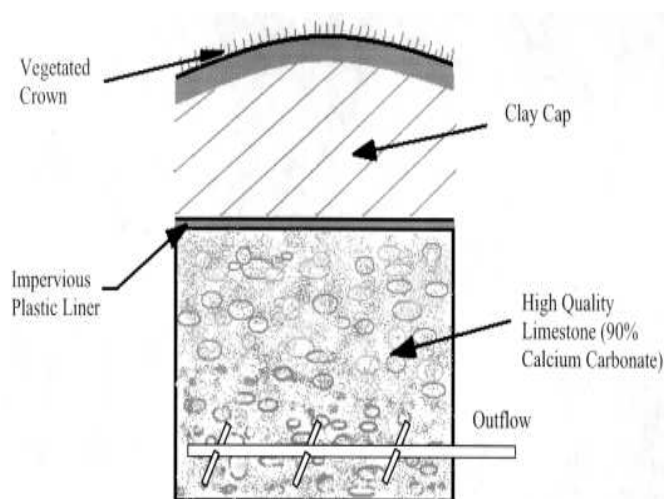

Figure 1.9: Cross section of an Anoxic Limestone Drain^[25].

→ Reducing and Alkalinity Producing Systems (RAPS)

First of all, it is worth mentioning that RAPS is the same as Successive Alkalinity Producing System (SAPS), Vertical-Flow Reactors (VFR), Vertical-Flow Wetland (VFW) or Vertical-Flow Pond (VFP), depending on the authors^[1, 10, 24, 27, 29] and on the concept in which these systems were conceived. For this purpose the acronym RAPS will be used.

These systems were introduced in the early 1990s by Kepler as a response to the limitations of ALD as referred^[1, 24]. RAPS unit combine the benefits of ALD and Anaerobic Wetlands (see Figure 1.10), being basically an ALD overlain by an organic layer to remove dissolved oxygen from water, and to reduce Fe^{3+} to Fe^{2+} before the water contact with the limestone bed^[1, 25, 27]. Further down, anaerobic conditions support the growth of SRB providing higher efficiency to the water treatment^[10]. The water flows vertically through the wetland increasing the contact time between the influent and the limestone bed devoid of oxygen, critical to prevent the armoring of limestone due to Fe^{2+} oxidation, into a underlying drainage pipes, which can work also as a flushing system mediated by a flush valve to prevent the cell clog, that convey the water into a settling pond or a aerobic wetland to allow metals to precipitate^[1, 10, 25, 27, 29].

RAPS are designed to treat water with dissolved oxygen content between 2 and 5 mg/L, and medium to high metal concentrations^[27]. The size is based on water retention times (12 to 15 hours) and acid removal rates^[25, 27]. A typical RAPS, has an 50 to 150 cm excavated cell to received acid water, over a layer of organic compost (15 to 60 cm thick) being the SRB nutrient which can be from spent mushroom, underlain by 50 to 150 cm of limestone^[1, 24, 29]. Below or within the limestone layer is a network of drainage pipes to convey the water to the settling ponds as has been mentioned^[24, 29].

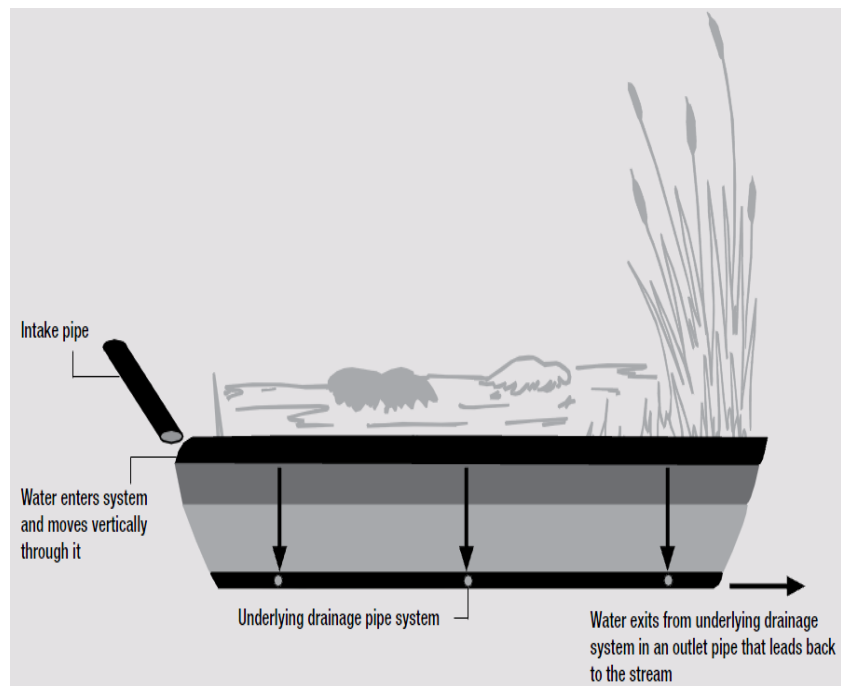

Figure 1.10: Cross section of a RAPS System^[27].

Brief note: An extensive overview regarding the reactions within the constructed wetlands systems and suitable constructing methods can be found in^[1, 24].

1.3 Zlaté Hory

1.3.1 Mining Activity in Zlaté Hory^[30, 31]

A tradition of subsurface mining of raw materials in the Czech Republic is one of the oldest in Europe. Zlaté Hory was first mentioned in historical records in 1222 and its colonization is closely associated with the occurrence of gold in the 12th century. It was promoted by two bishoprics, Wrocław (Poland) in the North and Olomouc in the South as shown in Figure 1.11.



Figure 1.11: Geographic location of Zlaté Hory^[32].

Since the mining activity started, around the 13th century, these lands reached a considerable mining boom. Late 14th and during the 15th century, decline occurs due to tumultuous time caused by the depletion of available metals and enhanced by the battles to conquer these lands. When the order was restored, the mining techniques were improved and with the support from entrepreneurs who were attracted by the reports of gold pieces found in the local mines, the mining industry rose again in the 16th century. In the same century, the melting furnace was invented by Francis of Teschen. In 1543 the first gold coins were minted and Zlaté Hory Mountain, the so-called Gold Mountain, became famous in Austria, Tyrol and Saxony.

In 1590 and 1591, bishop Andrew Jerina (1583 – 1596) found two soft nuggets weighing 1.385 kg and 1.780 kg. Both were dedicated to the collection of Emperor Rudolf II.

The cost of excavation was at that time 90,000 thalers, but the gold found during the excavation completely covered the costs. After this glorious period, the mining activity had another decline due to *Thirty Years War*. Around 1638, Princes Legnickie Duchy and Anhalt, devoted themselves to the production of pyrites and vitriol (sulphuric acid) which was a very profitable business and the city was emerging again. In the 2nd half of the 17th century the mines became again the subject of interest of several official committees. At the time, the

mine had about 65 miners who were able to extract from 5 to 10 kg of gold per year. However, between 1699 and 1702 due to the Prussian-Austrian war the Golden Hills were burned and as result, between 1730 and 1740 only 10 kg of gold were extracted. In the mid 19th century Johann Höniger began mining on Mount Cross, with the support of the local people. The definite end of the mining activities date back the year 1883.

Recent history of Zlaté Hory ore district began on October 19, 1952. It was initiated by the surface prospecting borehole at the Blue gallery. Firstly, the bearing area was examined in Zlaté Hory East and West. The survey went on digging trenches and excavating tunnels and crosscuts. Exploration drilling from the surface has also been performed in Zlaté Hory South bearing. This bearing is composed only by copper ore. The mine plant construction (Golden Hills RD) was completed in 1966 and at the same time exploitation of Zlaté Hory South bearing began. In 1989 the mining activities were focused on polymetallic ores (Cu, Zn, Pb, and Ag), in Zlaté Hory East. In 1990, mining of Cu, Zn and Au ore in Zlaté Hory West (see Figure 1.12) began.



Figure 1.12: Open pit at Zlaté Hory mining site in 1990^[31].

Following the publication of the Republic Government, Act 1990 program in ore mining, the mining activity began to reduce. Due to the new economic conditions, mining exploitation at Zlaté Hory East bearing ceased, leaving only the exploitation of gold ore deposit in the Zlaté Hory West. This period lasted until the end of 1993 and during this time, more than 1.200 Kg of gold were excavated.

Figure 1.13 shows the latest car of ore mined (December 17th of 1993) that is in exhibition at the DIAMO's entrance.



Figure 1.13: The last car of ore mined in 17th of December 1993^[31].

1.3.2 Geological Profile

1.3.2.1 Natural Conditions

The site is located on the North-East side of Hruby Jeseník land in the Golden Hills. The covered area is approximately 66 km² and has a strip with 6 km wide between the Golden Hills at North and Vrbno-Munich in the South. The terrain is mostly forested area and the altitude ranges from 550 to 960 meters above the sea level. The climate is cold with very high rainfall rates. The hydrological territory belongs to the Odra River basin.

1.3.2.2 Geological Conditions^[33]

Zlaté Hory is the major ore district in the region of Northern Moravia. Its importance is due to the number of mineral species identified in this place, over one hundred. From the geological point of view, Zlaté Hory is important for the presence of rich mineral associations, like minerals resulting from the weathering of primary sulphide ores. The existing minerals are relatively common, but are developed in the form of neat crystals, sometimes several centimetres large. Pyrite (FeS₂), is one of the most common minerals, most often consisting of granular aggregates (see Figure 1.14).

Sulphide ores in Zlaté Hory are a part of the volcano-sedimentary complex of metamorphic rocks (see Figure 1.14). These complex rocks were formed by the ore accumulation as a result of tectonic deformation. Its geological structure is therefore very complicated.

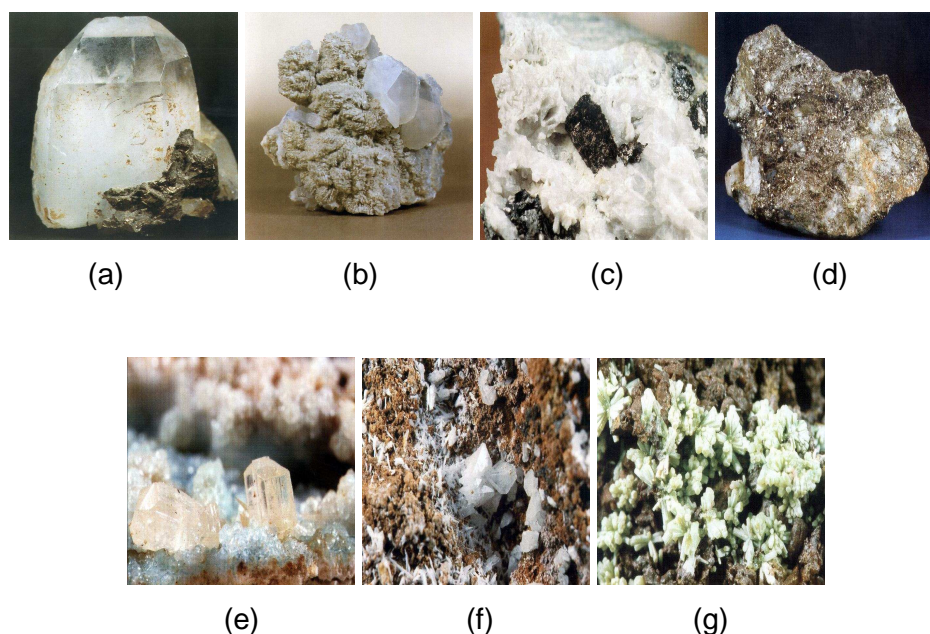

Figure 1.14: Examples of minerals present in Zlaté Hory: a – Quartz (SiO_2) + Pyrite (FeS_2); b – Calcite (CaCO_3); c – Sphalerite (ZnS); d – Galena (PbS); e – Cerussite (PbCO_3); f – Anglesite (PbSO_4); g – Pyromorphite $\text{Pb}_5(\text{PO}_4)_3\text{Cl}$

The stratigraphy¹ and structure of Zlaté Hory can be compared with other part of the Vrbno structure, which is a significant volcano-sedimentary horizon, so-called Cross Mountain quartzite. In this horizon, there are, besides quartzite, metamorphosed acidic volcanic rocks and pyroclastic rocks. Their composition, in accordance to the earlier terminology of these rocks is frequently referred to as “*quartzite keratophyres*” and “*quartzite keratophyres tuffs*”.

In the Cross Mountain bedrock, quartzite metasediments along with alkaline admixture predominate. Further down, below the bedrock, there is a layer of alkaline volcanic compounds present (now named green chlorite and chlorite slate), which gradually merge into metasediments, especially biotite. Overlying the quartzite, there is a layer composed by various metamorphic rocks, such as quartzite slates and crystalline limestone. The top layers are the so-called Heřmanovice limestone (calcite marble). The rocks present in the Vrbno structure are from the gneiss type and the overburden consists of culm sediments.

Throughout the Zlaté Hory district pyrite prevails over other minerals such as chalcopyrite, sphalerite, galena and gold. Ore bodies are soft and their definition is entirely due to the “*kovnatost*”² ore characteristics.

Depending on the geographic location, different types of mineralization can be found in Zlaté Hory. Thus, on the Western part dominates Au, Zn, Pb and Cu; on the Southern part Cu; on

¹ Stratigraphy, a branch of geology which studies rock layers and layering (stratification)

² “Kovnatost”, is the content of a particular interest in the ore, which is an important indicator for possible excavation element and its profitability

the Eastern part the ores are Pb, Zn, Cu, Ag and Au; Heřmanovice is characterised by the presence of Pb, Zn and Cu and in the North Cu.

→ **Zlaté Hory – West profile**

The bearing is developed in a tectonically predisposed structure with different types of acidic metavulcanites. The most important ore is formed in the contact between quartzite and acidic metavulcanites. In this site the ores consist of sphalerite, pyrite, chalcopyrite, galena, pyrrhotite and gold. Mineral composition of the ore bodies can be the result of complex mineral associations, to polymetallic ore with chalcopyrite or just sphalerite.

High levels of gold are concentrated in 1 up to 2 meters depth. Fine-grained pyrite along with chalcopyrite and sphalerite become the predominant ore minerals in the deeper parts.

→ **Zlaté Hory – East profile**

This site is formed by metamorphosed volcanic and sedimentary rocks, mainly quartzite. The polymetallic ore has in its composition, in addition to pyrite and chalcopyrite, sphalerite and galena. Pb and Zn can be found in the top layers and Cu in the bottom layers.

→ **Zlaté Hory – South profile**

The Southern part of Zlaté Hory ore district is characterised by the dominance of monometallic copper ore. There are two different types of ore bodies, strongly differing in structural and mineralogical composition. The first type is the result of contact between different types of chlorite-muscovite schist with quartzite. The second one is the so-called “*inner body*” and it was probably formed by the metamorphic mobilization in the ore. It is composed mainly by pyrrhotite and chalcopyrite.

→ **Zlaté Hory – Heřmanovice**

Polymetallic Pb-Zn mineralization, which occupies the upper part of the ore zone, and the monometallic copper mineralization at the bottom of the zone, are developed here. The contents of metals are low. Pb-Zn ore is stored in colourful bands formed by chlorite and muscovite quartzite, chlorite and muscovite schists. Dimensions of individual ore bodies depend on varied dimensions of the bands. The presence of silver needs to be emphasized.

1.3.3 Acid Mine Drainage Water – Basic Characteristics

Chemical characteristics of the acidic water in the natural wetland (see Table 1.2) were determined by regular sampling (see Chapter 2) from 2005 until 2008. The measurement points P4 and P3C can be consulted in Figure 1.15. All values were determined according to the collected data over the year, except the ones from 2008 which are based on one measurement only.

The acid water parameters of the constructed wetland (see Table 1.3) were measured from 2007 until 2009. All values were determined according to the collected data over the year. It is worth mentioning that the values from RAPS, sedimentation pond and wetland were measured in the output of each system as it is shown in Figure 1.15.

Table 1.2: Acidic water characteristics from the natural wetland.

Year	Measurement Place	pH	Acidity (mmol/L)	Alkalinity (mmol/L)	Fe (mg/L)	Mn (mg/L)	Sulphate (mg/L)
2005	P4	5.69	1.90	0.69	78.5	15.0	921
	HM1	6.42	1.33	1.17	72.3	6.3	570
	HM3	6.69	0.57	0.80	16.7	14.9	571
	HM4	6.94	0.5	1.03	3.9	0.3	421
2006	P4	5.99	1.73	0.98	88.0	16.2	1007
	HM1	6.28	0.98	0.82	49.4	7.5	687
	HM3	6.30	0.45	0.56	3.3	3.9	597
	HM4	6.57	0.35	0.89	1.8	0.1	400
2007	P4	6.24	2.06	0.83	237.4	16.2	958
	HM1	6.62	0.91	1.18	106.6	7.4	458
	HM3	6.79	0.39	0.69	6.2	14.5	524
	HM4	6.89	0.36	0.79	0.5	0.2	371
	M	6.99	0.33	0.96	0.7	0.7	402
2008	P4	6.12	2.24	1.00	41.1	14.6	1010
	HM1	6.71	0.89	1.30	119.0	9.5	513
	HM3	6.69	0.40	0.80	3.8	4.0	559
	HM4	6.66	0.50	1.10	15.8	3.1	578
	M	6.68	0.30	0.90	0.7	0.7	533

Table 1.3: Acidic water characteristics from the artificial wetland.

Year	Measurement Place	pH	Acidity (mmol/L)	Alkalinity (mmol/L)	Fe (mg/L)	Mn (mg/L)	Sulphate (mg/L)
2007	P3C	6.52	1.47	1.20	23.1	7.8	358
	RAPS	6.50	1.00	2.04	9.6	7.5	345
	Sedim. Pond	6.67	0.81	1.97	7.1	7.1	344
	Wetland	6.77	0.66	1.97	2.9	5.5	331
2008	P3C	6.69	1.76	1.12	30.7	8.2	395
	RAPS	6.59	1.15	2.23	8.3	8.5	375
	Sedim. Pond	6.91	0.81	2.18	4.3	8.1	373
	Wetland	6.99	0.71	2.03	1.9	5.2	370
2009	P3C	6.78	2.09	1.09	35.0	9.0	429
	RAPS	6.43	1.30	2.20	13.0	8.7	421
	Sedim. Pond	6.86	1.14	2.13	8.1	8.5	418
	Wetland	7.04	1.10	1.86	3.6	6.9	404

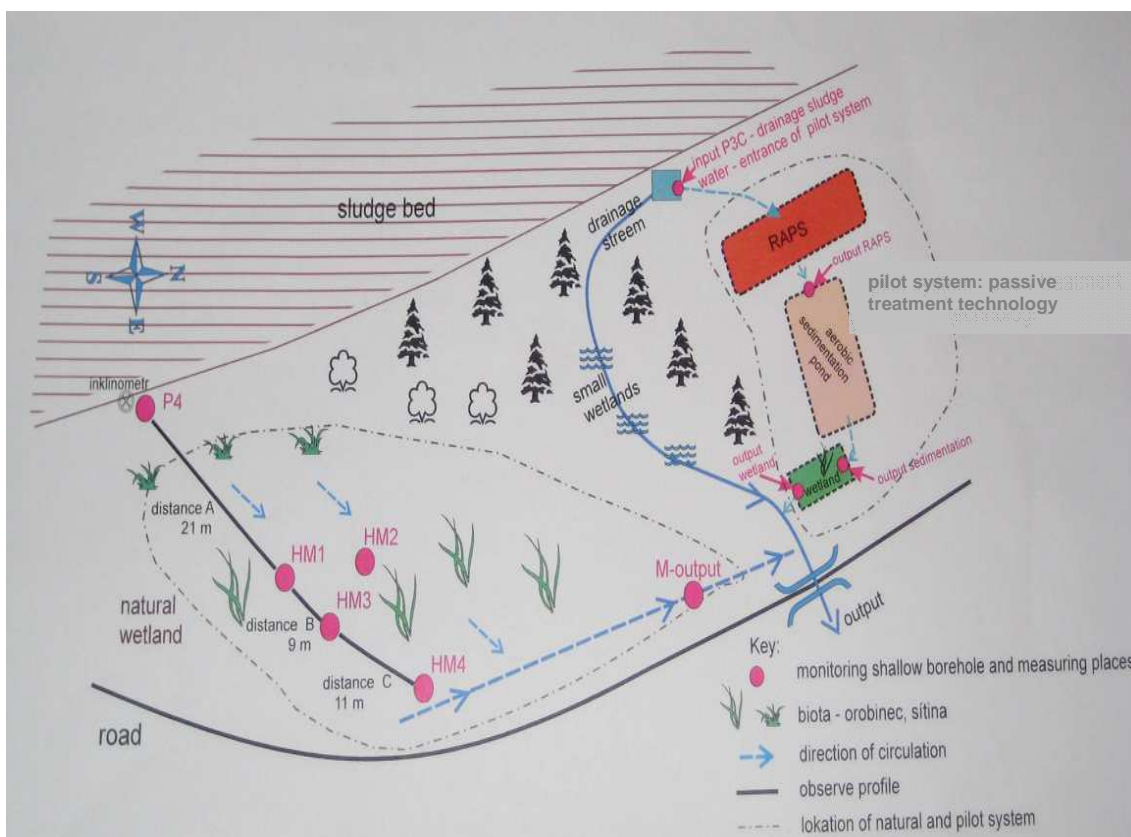

Figure 1.15: Pilot and natural treatment plant in Zlaté Hory.

1.4 Treatment System Applied in Zlaté Hory

1.4.1 Natural Wetland

The existence of natural wetland in the Zlaté Hory mining site plays a very important role in the treatment of acidic mine water. However, understanding of the complex chemical and biological process within the wetland is the major challenge. Therefore, research and development within this field has attracted experts ranging from chemical engineers, aquatic biologists, ecologists, and wildlife specialists to landscape architects, civil engineers, and others^[34].

In Zlaté Hory, the efforts to comprehend these processes gained crucial importance since it was discovered that this natural wetland could achieve better metal removal rates (see Chapter 3) than the constructed wetland. The purpose of this section is to describe the wetland in Zlaté Hory but given its importance and efficiency for metal removal, a brief overview of how these natural systems works will be approached.

Wetlands are the lands located in wet areas. They can be diverse according to vegetation, soil and hydrogeology. Thereby, the characteristics and functions of a given wetland can be determined by the position of the landscape, climate, hydrology, vegetation and soil^[35].

Chemical treatment takes place when the incoming compounds react with oxygen, soil and minerals. Biological treatment occurs through the uptake by plants or nutrients such as nitrogen, phosphorus and potassium compounds^[36]. Their characteristics are adequate for the treatment of contaminated water due to slow flows which prolong the contact time between the water and the wetland surface allowing sediments to settle^[37]. Vegetation is very important within the natural wetlands. Along with slowing the water flow, vegetation creates microenvironments and provides microbial community attachment sites. Further, plants die and as a result the dead material can turn into an organic soil. This creates additional material and exchange sites as well as provides a source of carbon, nitrogen and phosphorous to fuel microbial processes^[36,37].

The natural wetland in Zlaté Hory is about 1000 m² and it is situated in the slope base of the sludge bed, former open mine pit. It has three inputs, one is located on the upper left side designated as P4 (see Figure 1.15) and the other two on the upper right side and its source is the shaft P3C (see Figure 1.15 and 1.16). One input flows directly from the shaft to the natural wetland (see Figure 1.16) and the other input derives from the tube which was installed in the shaft to exit in the upper middle part of the wetland (see Figure 1.15). This allows distribution of acid mine water within the wetland. The upper left sided input and the upper middle input flow through a small slope of the wetland into an excavated ditch (see Figure 1.17) which is

directed to the main output (see Figure 1.18 and 1.26). The other flows through the wetland directly to the main output.



Figure 1.16: Contaminated flow from shaft P3C.



Figure 1.17: Excavated ditch.



Figure 1.18: Main output.



Figure 1.19: Aerial view of the Zlaté Hory treatment facility^[38].

1.4.2 Constructed Wetland

The constructed wetland in Zlaté Hory followed the guidelines of reference^[1] adjusted to the site characteristics and water properties. The mountain region of Zlaté Hory was chosen for the implementation of the remediation project since exists a natural lagoon, enabling a comparative study of the two systems (natural and artificial). The purpose of this project is to study the constructed wetland efficiency regarding metal removal rates from acidic mine water in order to further implement these structures to treat other mine sites.

The system begins at P3C shaft (see Figure 1.20). At the bottom of the shaft there is a pipe which provides connection between the sludge bed (see Figure 1.15) and the shaft itself, which contains acidic water targeted for treatment. On the top of the shaft a polyethylene pipe was installed (see Figure 1.20 and 1.21) to divert the water to the first pond (RAPS).



Figure 1.20: Constructed wetland input (P3C)

The pipe has a regulation valve (blue equipment) see Figure 1.20, to control the flow rate. This flow rate is in optimal conditions approximately 0.2 to 0.5 L/s, to be adequate for the pond dimensions, as well to enhanced retention times needed for metal precipitation further in the system. The RAPS system was covered with plastic foil (see Figure 1.21) to isolate the system from oxygen, thus creating proper anaerobic conditions for microbiological activity, reducing sulphide and keeping iron in reduced state of Fe^{2+} . Since the purpose of this system is to add alkalinity to the water and not precipitate metals, which could clog the drainage pipes installed on the top of the plastic foil, it is crucial to isolate it properly.



Figure 1.21: RAPS pond covered with plastic foil.

On the top of the foil a layer with limestone ($CaCO_3$) was placed to increase water alkalinity, and on top substrate to eliminate dissolved oxygen. The substrate is composed by spent mushrooms (nutrient for bacteria growth), wood chips and limestone to create the anaerobic conditions as referred in section 1.4.2.2. Figure 1.22 shows this layer.



Figure 1.22: Organic layer in the RAPS system.

As has been said previously, a set of drainage pipes (see Figure 1.23 and 1.24) was placed at the bottom of the plastic foil, having two functions. Firstly, water from the basin is allowed to enter the pipe which will be sent up the pipe system to further collect the water samples (see Figure 1.23). The other allows water to flow to the sedimentation pond. The four pipes allow water to flow continuously, even if the water hydraulic pressure decreases due to clogging or if the water level is lowered.



Figure 1.23: Drainage pipe.

It is worth mentioning that this system does not have a flushing system which could prevent the drainage system from clogging. As a consequence, sometimes all the pipes clog and it is necessary to adjust the hydraulic pressure regulating the valve to increase the flow rate so that water can flow to the sedimentation pond again.

The second structure of this project as been said previously is the sedimentation pond. The water flows through the four drainage pipes (see Figure 1.24b) into the sedimentation basin. The retention time should be around 1 to 2 days in order to efficiently oxidize Fe^{2+} to Fe^{3+} and further precipitation as $\text{Fe}(\text{OH})_3$. In the output of this basin there is a perforated collector (see Figure 1.24a) to balance the distribution of the flow in all basin enhancing the hydraulic loadings.



Figure 1.24: **a)** Sedimentation pond. **b)** Set of four drainage pipes.

The purpose of the third and final basin (see Figure 1.25) is to clarify the water in order to reduce metal concentration to negligible values. This is enhanced by vegetation (*Juncus effusus*) planted in this basin to help retain metals by adsorption. In good conditions, the metal concentration at this stage is low and it is difficult to precipitate. Thereby vegetation was implemented to optimize the efficiency of the system.



Figure 1.25: Wetland basin.

Finally, the wetland output (Figure 1.26) is the same as the natural wetland, which afterwards flows to the storage tank, as has been mentioned in Section 1.4.1.



Figure 1.26: Constructed wetland output.

2: Materials and Methods

2.1 Field Measurements

The samplings taken in the natural wetland were carried out by two methods. The boreholes HM1, HM2, HM3 and HM4 (see Figure 1.15) were sampled by the dynamic method using a small pump GIGANT with flow capacity of 0.01 L/s. The smaller boreholes P21, P22, P23, P28, P27 and P26 (see Figure 3.11) were sampled by the static method using a liquid sampler of Teflon. Measurements of the surface water in the wetland were also performed using the static method. In the pilot system case, sampling was carried out using the dynamic method. The samples were taken from the outputs of RAPS, Sedimentation Pond and the Wetland respectively.

Regarding the water samples preparation for the metal analysis, they were filtrated *in-situ* and 1 mL of HNO_3^- was added to each water recipient to preserve the sample for the laboratory analysis. The samples were transported in a cooled box and delivered to the Aquatest laboratory within 24 hours.

In-situ monitoring parameters were also performed and involved measurements of water level using a water level meter from Solinst – Canada, physical and chemical parameters such as pH, temperature, conductivity, redox potential and oxygen saturation using the Multi 350i/SET from WTW – Germany and measurement of iron, manganese and sulphate using a RQ-flex plus reflectometer from MERCK – Germany.

The sampling and conservation methods of water samples followed the norms: ČSN EN 25 667-2: water quality – guidance on sampling of drinking water and used for food and beverage processing^[39]; ČSN EN ISO 5667-3: water quality – guidelines for preserving samples and handling^[40]; ČSN ISO 5667-11: water quality - guidance on groundwater sampling^[41].

2.2 Laboratory Analysis

The laboratory analysis pays special attention to the parameters measured *in-situ* as referred in section 2.1. Analysis of HCO_3^- , Na^+ , K^+ , Mg^{2+} and Ca^{2+} were made to determine the water characteristics. Analysis of cations and anions existing at trace levels were also performed as well as measurements of alkalinity of acidity from the water samples collected at the site.

This part of the project was performed exclusively by the laboratory technicians.

3: Results and Discussion

3.1 Natural Wetland

Since this project began in 2005, studies performed on the wetland have involved monitoring of geochemical processes along horizontal profile P4 – HM1 – HM3 – HM4 according to Figure 1.15. The boreholes are 0.8 m deep and made of PVC perforated at the bottom^[42] allowing the water to rise from different depths adding homogeneity to water. The boreholes have different lengths between each other to allow a better description of processes happening within the wetland. The rock layers can be characterized as a dark-sandy clay rock^[42] and the presence of large amounts of organic matter within the wetland area can be noticed as shown in Figure 3.1.



Figure 3.1: Organic matter present in the natural wetland.

In the upper part of the wetland, especially between boreholes P4 and HM1, there are visible zones of great rusted iron hydroxides as shown in Figure 3.2.



Figure 3.2: Wetland zones covered by iron hydroxides.

The water flow (Q) has an average value of 0.18 L/s and was determined in output M (see Figure 1.15) on 10-04-2007 which achieved the value of 0.14 L/s and on 13-06-2007 a value of 0.21 L/s. The height gradient measured from P4 to HM4 is 3.1 m.

3.1.1 Long Term Observation of Profiles and Outflow

The long term observation of the wetland profiles focuses mainly on three major pollutants: total iron (Fe), manganese (Mn) and sulphate (SO_4^{2-}). Monitoring of pH, acidity, alkalinity, dissolved oxygen (DO), oxidation-reduction potential (ORP) and conductivity which is directly linked to the amount of total dissolved solids (TDS) are also parameters which deserve attention. The results of these observations will be presented further in this section. The results regarding the Fe and Mn measurements are from laboratory analysis due to a more complete data profile and the sulphate results are from collected field data. All values of temperature, pH, DO, ORP, and conductivity were measured on the field.

Regarding the pH evolution over time along the wetland profile (see Figure 3.3), it is visible that the increase of pH value from P4 ($\text{pH}_{\text{avg}}=6.1$) to M ($\text{pH}_{\text{avg}}=7.2$). The distance of 21 m between input P4 and borehole HM1 (see Figure 1.15) may explain the increase in pH values between these points. However from HM4 to M, such pH increase is not expected given the proximity of borehole HM4 to the excavated ditch (see Figure 1.15 and 1.17) where point M is located. Nevertheless in January of 2009 the pH values were surprisingly high especially in P4 and HM1.

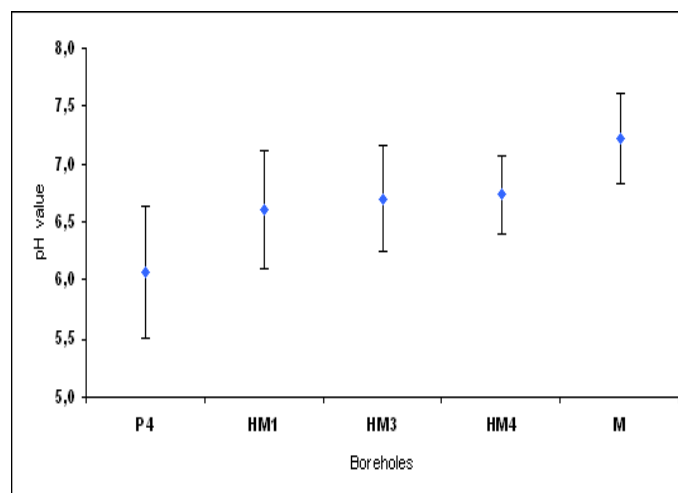

Figure 3.3: Average pH evolution over time along the natural wetland profile.

Water temperature is a very important parameter which is worth considering due to the fact that it affects the metal removal rates as it will be shown further. The referred values ranged

from an average value of 3.5 °C in the winter (January to March) to 14 °C in the summer (June to August).

From the collected data, it is possible to verify that water temperature showed very low values in the winters of 2008 and 2009, in the considered months, reaching inclusive 0 °C.

3.1.1.1 Iron Removal Rates

The wetland efficiency for Fe and Fe²⁺ removal attains optimal values. From an average Fe and Fe²⁺ concentrations of respectively 4.6 mg/L and 4.1 mg/L in P4, reaching borehole HM4 the concentrations are 0.14 mg/L and 0.03 mg/L. Considering that only pure natural processes are involved, the results presented in Figure 3.4 show the potential of these systems in the treatment of iron from AMD. Nevertheless, some considerations need to be clarified. The Fe concentration is about three times higher in HM1 than in P4 in the measurement made on 28-05-2008, which suggests that the sample could be contaminated. On the other hand, the low concentration of Fe measured in January 2009 reveals the complexity of this natural system.

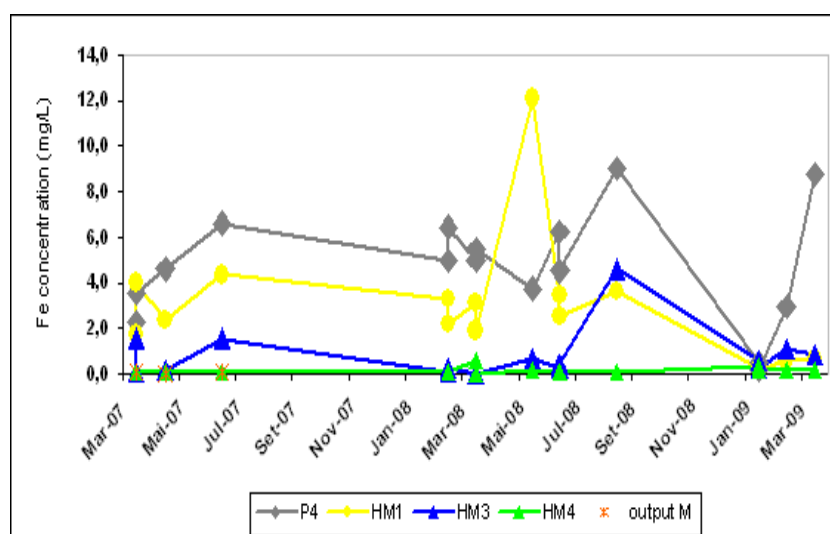

Figure 3.4: Evolution of Fe removal over time in the natural wetland.

The Figure 3.5 indicates the percentage of Fe removal along the wetland profile. Curiously, the highest percentage of removal is in the shortest segment of the horizontal wetland profile. This fact is associated with iron remediation process. Thereby, it can be assumed that in Section A (see Figure 1.15), occurs Fe²⁺ oxidation and then, in Section B the Fe³⁺ will precipitate as equations 3.1 to 3.3 shows^[1].



where “sus” indicates a suspended solid and “sed” indicates a sedimented solid.

Fe oxidation is dependent on pH, as well as on the concentration of dissolved oxygen. These parameters play an important role in the type of results achieved.

The results presented in Figure 3.5 shows that 97% of Fe is removed from the water.

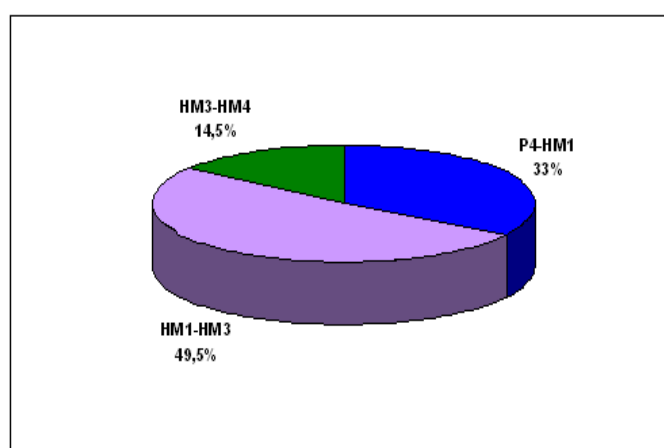

Figure 3.5: Fe removal (%) along the natural wetland profile.

3.1.1.2 Manganese Removal Rates

The average concentration of Mn in the input point P4 is 14.6 mg/L. As in the case of Fe and Fe^{2+} removal, here the bioremediation system also provides better results. From 14.6 mg/L in P4, the system is able to achieve in HM4 a concentration of 0.07 mg/L and in output M the values measured were below the detection limit of the method used (see Figure 3.6). The concentration of Mn in P4, along the monitored period, 2007 until the beginning of 2009, stays stable. In Figure 3.6 it is possible to observe a high increase of Mn which could be related with the differences of atmospheric temperatures or it could be connected with natural phenomenon's. Figure 3.6 also shows Mn concentration increases in summer months and decreases in the winter time.

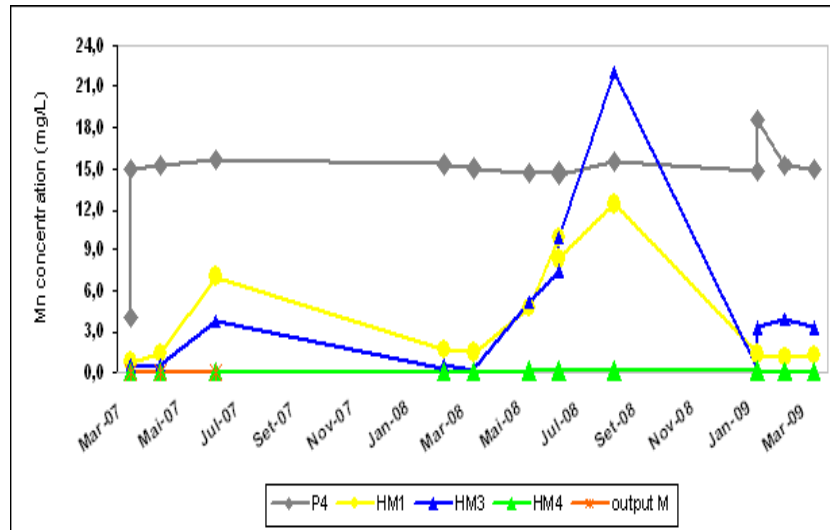

Figure 3.6: Evolution of Mn removal over time in the natural wetland.

The Figure 3.7 indicates the percentage of Mn removal along the wetland profile. Section A (see Figure 1.15), is vital for Mn precipitation allowing to remove 80% of total Mn. In this particular case, removal rate along the wetland profile is 100% which is remarkable.

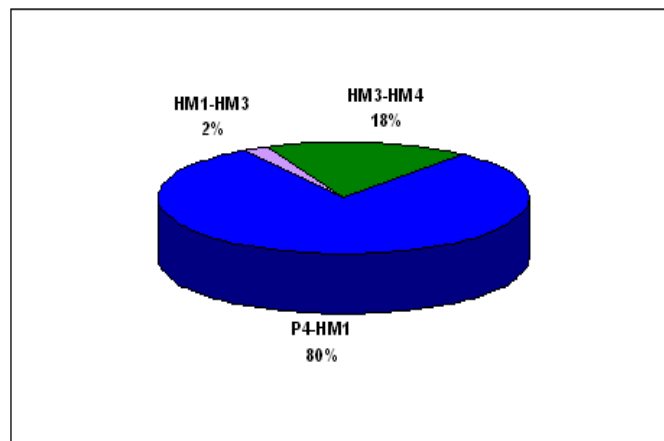

Figure 3.7: Mn removal (%) along the natural wetland profile.

3.1.1.3 Sulphate Removal Rates

The Figure 3.8 shows the sulphate concentration being nearly constant at the input point, with an average value of approximately 950 mg/L. Collected data indicates that the highest decrease in the sulphate concentration is in Section A (see Figure 1.15) and also shows that conductivity is linked to sulphate removal rates since it dropped 1/3 of the initial average value in the referred Section (see Figure 3.9). Conductivity is associated with TDS, and in the wetland the major metal in terms of high concentrations is the sulphate. It is precisely because of this fact, that conductivity is linked to the sulphate removal rates. In Section C (see Figure 1.15) the concentration of sulphate as well as conductivity followed the expected trend.

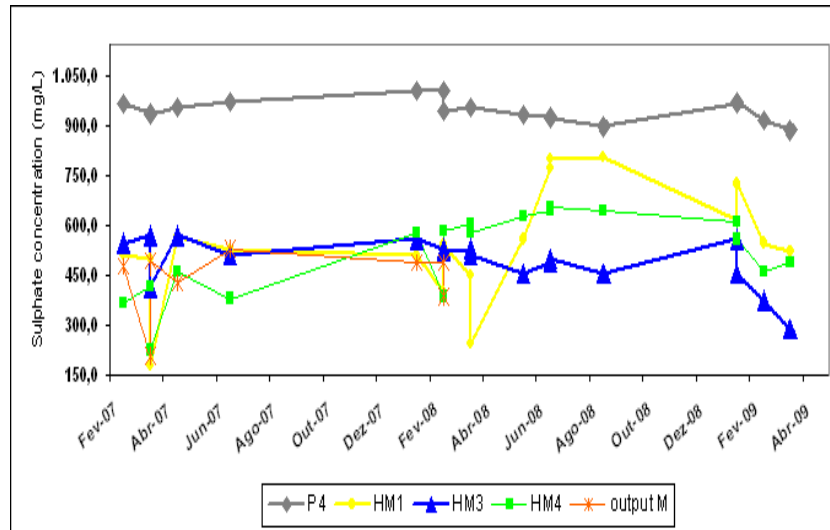

Figure 3.8: Evolution of sulphate removal over time in the natural wetland.

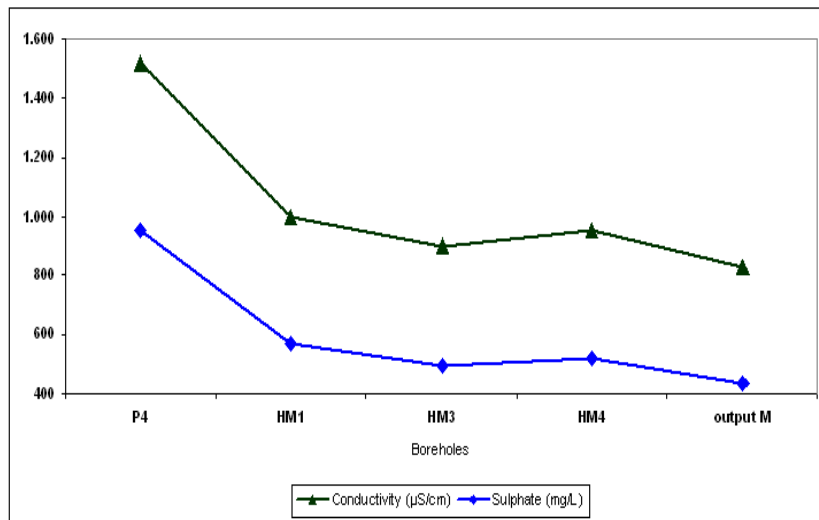

Figure 3.9: Conductivity dependence on $[SO_4^{2-}]$.

Regarding the wetland efficiency, the existence of considerable levels of sulphate in the output M, approximately 440 mg/L, corresponding to an overall efficiency of approximately 45% (see Figure 3.10). In section C (see Figure 1.15) efficiency is negative due to increasing sulphate concentration.

Studies performed in 2010 have shown that the sulphate concentration measured in borehole HM3, does not correspond to the previously determined water path (see Figure 1.15). Instead there is another input source (see Figure 3.11 **st1**). For this reason, the sulphate concentration in HM3 is lower than in HM4.

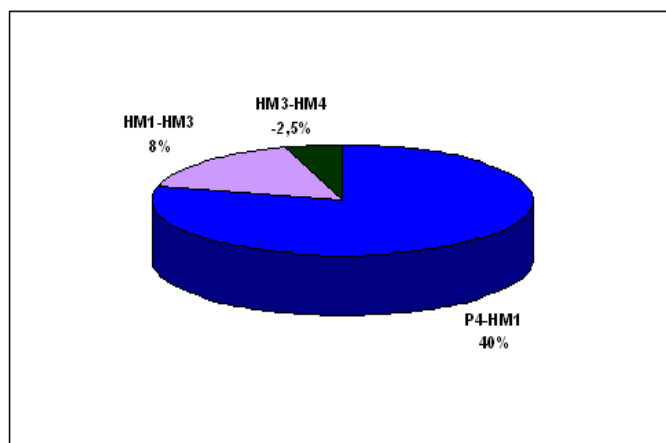

Figure 3.10: Sulphate removal (%) along the natural wetland profile.

Table 3.1 displays an overall overview of pollutants amount removed per year during the collected data study from 2007 until 2009. The values have some deviation from the real true values because the measurements were not made regularly throughout the year. Therefore, the presented values only show an estimative of the wetland potential concerning annual removal quantities.

Table 3.1: Annual metal removal rates in tons per year.

Section	Boreholes	Fe ²⁺ (ton y ⁻¹)	Fe (ton y ⁻¹)	Mn (ton y ⁻¹)	SO ₄ ²⁻ (ton y ⁻¹)
A	P4 - HM1	3.2	2.8	21.4	704
B	HM1 - HM3	3.5	4.2	0.6	140
C	HM3 - HM4	0.8	1.2	4.8	-44
Total	P4 - HM4	7.5	8.2	26.7	800

3.1.1.4 Comparison Between Previous and Current Study

Table 3.2 presents the results of the wetland study performed from 2005 to 2008 with the one performed from 2007 and 2009.

Table 3.2: Comparison between 2005 – 2008^[42] and 2007 – 2009 studies.

Section	Boreholes	2005 - 2008								2007 - 2009							
		Fe ²⁺ (mg/L)	Fe ²⁺ (%)	Fe (mg/L)	Fe (%)	Mn (mg/L)	Mn (%)	Sulphate (mg/L)	Sulphate (%)	Fe ²⁺ (mg/L)	Fe ²⁺ (%)	Fe (mg/L)	Fe (%)	Mn (mg/L)	Mn (%)	Sulphate (mg/L)	Sulphate (%)
A	P4 - HM1	1.4	20.0	1.6	32.0	9.5	68.0	398.0	41.0	1.7	42.5	1.5	33.0	11.6	80.0	382.7	40.2
B	HM1 - HM3	2.6	64.0	2.4	54.0	2.0	13.0	24.0	2.7	1.9	46.0	2.3	49.5	0.3	2.0	76.3	8.0
C	HM3 - HM4	0.4	7.0	0.7	12.0	2.4	17.0	53.0	5.3	0.5	11.0	0.7	14.5	2.6	18.0	-23.7	-2.5
Total	P4 - HM4	4.4	100.0	4.7	98.0	13.9	98.0	475.0	49.0	4.1	99.5	4.5	97.0	14.5	100.0	435.3	45.7

Observation of both studies suggests that the wetland has remained stable over the years. The overall removal rates and efficiency are practically the same, just slightly different in the sulphate case. Nevertheless, it is possible to observe changes along the wetland profile.

3.1.2 New Observation Points Installed in 2010

In the beginning of 2010, studies performed in the wetland were extended to soil measurements. The main purpose of this study is to add more information about microbial processes within the wetland especially those promoted by Sulphate-Reducing Bacteria (SRB). The type of interactions of these microorganisms with metals and in which conditions they operate with better efficiency is the aim of this study. The samples were taken from different places (see Figure 3.11) within the natural wetland to define its profile in accurate way. This study has been carried out with the cooperation of Masaryk University – Brno. Soil samples were analysed by the Geochemist Department of this university. New monitoring boreholes (P21, P22, P23) and (P28, P27, P26) were placed along the horizontal profile in the main flow pathway (P4 → HM2) as indicated in Figure 3.11. All were perforated at the bottom. The borehole characteristics are as follows:

- Borehole material - PVC
- P21 – total depth 1.4 m; perforation depth 1.1 to 1.4 m;
- P22 – total depth 0.9 m; perforation depth 0.5 to 0.8 m; distance P21 – P22 0.25 m;

- P23 – total depth 0.4 m; perforation depth 0.1 to 0.4 m; distance P22 – P23 0.30 m; distance P4 – P23 9.6m;
- P28 – total depth 1.4m; perforation depth 1.1 to 1.4 m;
- P27 – total depth 0.9 m; perforation depth 0.5 to 0.8 m; distance P28 – P27 0.25 m;
- P26 – total depth 0.4 m; perforation depth 0.1 to 0.4 m; distance P27 – P26 0.19 m.

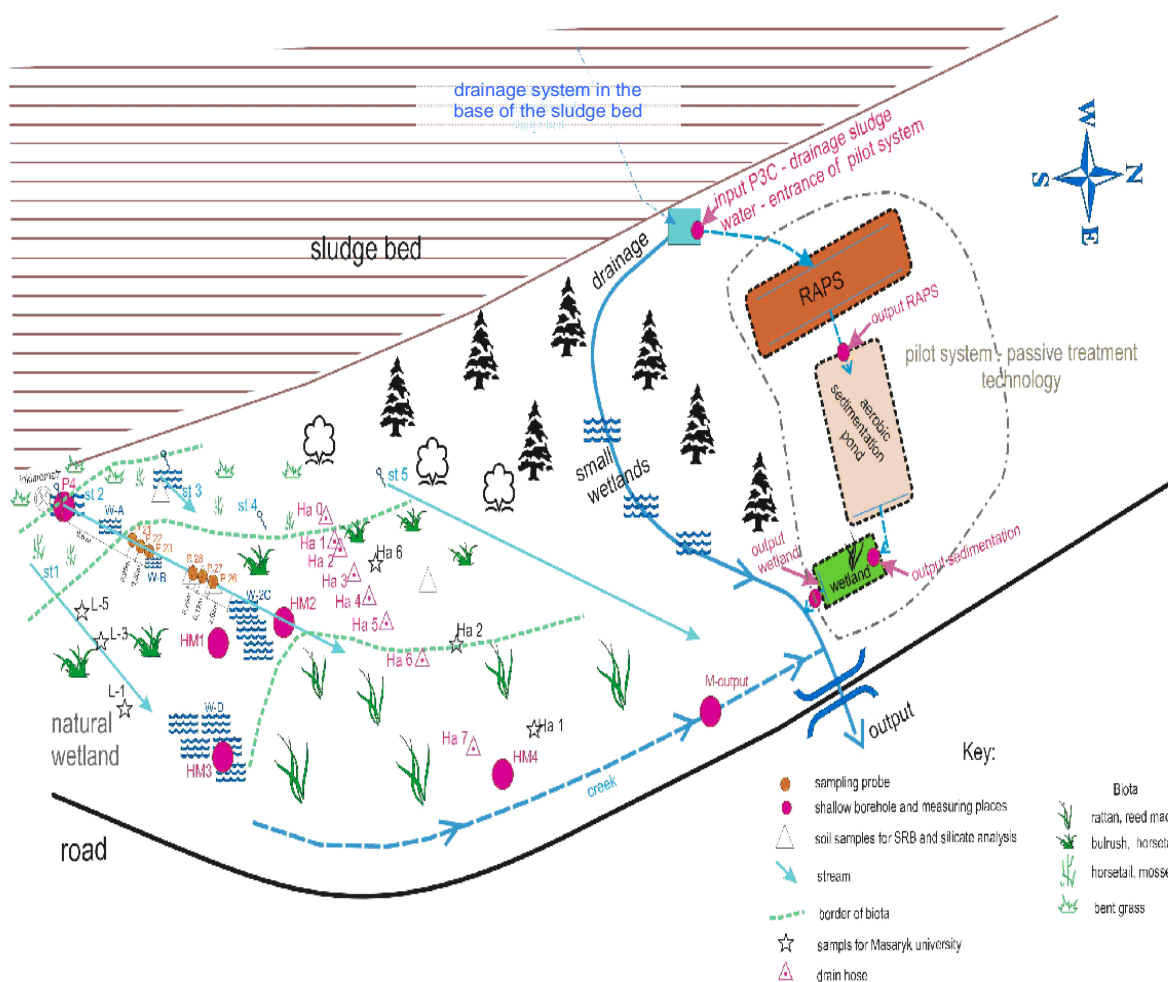

Figure 3.11: Scheme of new studies performed in Zlaté Hory's wetland.

The soil samples taken in boreholes P21 to P23 have shown the following soil characteristics:

- 0 to 0.2 m – humic clay;
- 0.2 to 0.8 m – soft sandy clay;
- 0.8 to 1.5 m – sandy clay with round stones;
- > 1.5 m – hard rock

In addition, it was observed that from 0 to 1.0 m depth the soil was highly saturated with water and below this depth soil saturation decreased.

In order to understand the role of these bacteria, more measurements have to be conducted during a longer period of time. Nevertheless, from the collected data (see Table 3.3) it is possible to observe that the Fe and Fe²⁺ are mainly removed at the surface within less than 0.5 m layer. As the soil profile increases in depth, it shows a small amount of Fe and none Fe²⁺.

Regarding Mn and sulphate, both are removed until significant depths, approximately 1.5 m. This was observed in the first 9.5 m of horizontal profile (P4 – P23). Since there is no available data from measurements made on 10-05-2010, concerning the study objects P21, P22 and P23 the next conclusions are based on the values from study objects P28, P27 and P26. Few meters down the horizontal profile the situation has changed significantly. Here great amount of Fe, Fe²⁺ and Manganese have been removed at approximately 1.5 m depth. The sulphate concentration has decreased about seven times. Once again it is possible to observe the dependence between conductivity and sulphate removal rates.

Table 3.3: Results of new studies performed in 2010.

Date	Borehole	Temp. °C	pH	ORP (mV)	Conductivity (µS/cm)	O ₂ (mg/L)	Fe ²⁺ (mg/L)	Fe (mg/L)	Mn (mg/L)	SO ₄ ²⁻ (mg/L)
07-04-2010	P21	8.1	6.5	176.0	1275	0.2	0.0	0.06	17.1	787
	P22	8.9	6.3	223.4	1315	1.3	0.0	0.10	18.1	772
	P23	7.7	6.3	218.1	1377	0.8	2.8	2.75	20.3	874
10-5-2010	P21	13.7	6.9	113.5	1116	0.0	-	-	-	-
	P22	11.6	7.0	60.4	957	0.0	-	-	-	-
	P23	10.1	6.9	79.6	586	4.6	-	-	-	-
10-5-2010	P28	10.7	7.4	180.0	368	0.0	2.6	517 *	511 *	102
	P27	9.1	7.1	149.9	354	0.0	1.3	373 *	217 *	114
	P26	10.4	7.4	169.6	486	0.0	2.8	503 *	212 *	118

Note:

* - Unfiltered metals

3.1.3 Wetland Processes

As previously mentioned, the wetlands are very complex systems and in order to have a more complete explanation of all these processes, further studies regarding bacteria interaction, vegetation uptake and kinetics have to be performed. Nevertheless, some of those processes are understood and will be presented in this Section.

3.1.3.1 pH variation profile

The pH variation is dependent on the availability of carbonate minerals (e.g. CaCO_3) within the wetland profile. The reaction between CO_2 with carbonate minerals in the water will originate carbonate hydroxide (HCO_3^-) increasing alkalinity and consequently pH. The equation 3.4 explains this process.



Observation of Figure 3.12 shows these variations within the wetland profile.

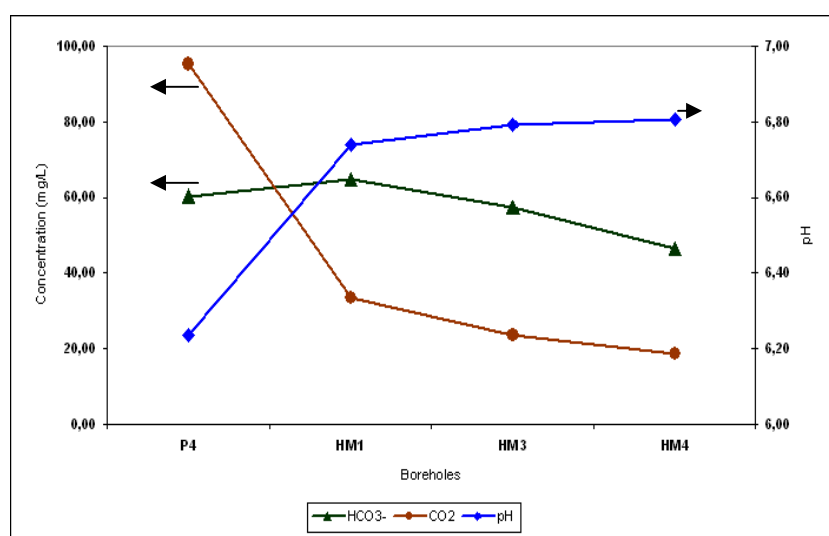

Figure 3.12: HCO_3^- , CO_2 and pH dynamics along the wetland profile.

3.1.3.2 Metal Removal Processes

Chemical and microbial processes have direct influence on metal uptake rates. However, the weather conditions play an important role in these processes especially in a place like Zlaté Hory. Here the weather conditions can be characterized as moderately warm and humid with an average annual temperature between 7 – 8 °C^[42]. In the winter temperature can drop significantly which affects the removal rates. If the wetland is exposed to very low temperatures for a period of time the top layer can freeze and therefore oxygen cannot dissolve in the water, slowing down metal oxidation. In conclusion, metal removal rates are dependent on seasonal variations as it will be shown further in this section.

→ Iron Removal

The iron removal can be carried out by oxidation, where Fe^{2+} is first oxidized to Fe^{3+} which is after hydrolysed forming $Fe(OH)_3$ (sus) and will further deposit (see equations 3.1 and 3.2); or in anoxic conditions by the formation of iron sulphides and iron carbonates (see equations 3.5 and 3.6). Oxidation can occur by chemical or biological processes, both being dependent on pH. Chemical dominates over biological at pH 6 – 7^[1], thereby in this particular case it can be said that the Fe and Fe^{2+} removal rates are depending mostly on chemical processes since the pH in the wetland has about the same range (see Figure 3.3). Therefore, the influence of weather conditions will be determinant for iron oxidation. The formation of iron sulphides and iron carbonates are dependent on alkalinity rates, therefore it can be possible to say that these processes only are able to occur in Sections B and C since the water in Section A is net acidic.

Iron Sulphides and Iron Carbonates formation processes^[1]:



Despite the small differences between summer and winter in Fe and Fe^{2+} removal rates, in the summer the removal is more efficient as Table 3.4 shows. Also, in the summer a higher quantity of iron is removed.

Table 3.4. Seasonal variation in Fe and Fe^{2+} removal rates.

Section	Boreholes	Winter				Summer			
		Fe mg/L	Fe %	Fe^{2+} mg/L	Fe^{2+} %	Fe mg/L	Fe %	Fe^{2+} mg/L	Fe^{2+} %
A	P4 - HM1	1.7	43.7	1.7	45.9	3.1	47.0	2.4	45.7
B	HM1 - HM3	1.7	43.4	1.7	47.7	1.8	26.6	0.7	13.0
C	HM3 - HM4	0.3	8.5	0.2	5.2	1.7	25.4	2.2	41.2
Total	P4 - HM4	3.8	95.6	3.6	98.8	6.5	99.0	5.3	99.9

→ **Manganese Removal**

Manganese can be removed by oxidation of Mn^{2+} and further hydrolysis of Mn^{4+} as demonstrated by equations 3.7 and 3.8^[1].



Manganese removal is strongly dependent on pH. Chemical oxidation rates of Mn^{2+} are very slow at pH values below 8, which is the case in the wetland (see Figure 3.3), therefore Mn^{2+} oxidation is usually catalysed by microorganisms. Besides bacteria, algae and fungi are also part of oxidative precipitation of MnO_2 ^[1]. Moreover, some catalysing microbes are intolerant to pH values lower than 6. Manganese oxides are also very unstable at lower pH values due to their increasing solubility^[1]. The results showed that pH variations along the year are insignificant, being constant between pH values of 6 and 7. Therefore, it can be assumed that Mn removal from this system is mainly carried out by bacterial activity along the year. Data reveals the same removal rates and efficiency during the winter and summer months. However, during the winter, Section A (see Figure 1.15) proved to be very efficient, over 90% and in the summer the efficiency is distributed mainly by Sections A and C (see Figure 1.15) as Table 3.5 demonstrates. The hypothesis that Mn removal is highly dependent on microbial activity, is the observation of Section B. It seems that manganese removal rates are not correlated with seasonal variations (see Table 3.5). In addition, in the winter, the water flow decreases and allows higher microbial uptake. Perhaps this can explain the 90% removal in the winter in comparison with 44% in the summer. These results have showed that during the winter, bacterial activity is as well able to remove Mn. Once again this is an example of the system complexity.

Table 3.5. Seasonal variation in Manganese removal rates.

Section	Boreholes	Winter		Summer	
		Mn mg/L	Mn %	Mn mg/L	Mn %
A	P4 - HM1	13.0	90.6	6.7	44.1
B	HM1 - HM3	0.04	0.2	1.4	9.3
C	HM3 - HM4	1.3	8.8	6.9	45.8
Total	P4 - HM4	14.3	99.6	15.0	99.2

→ Sulphate Removal

Sulphate can be removed by chemical precipitation as gypsum (see equation 3.9)^[43] or by SRB (see equation 3.10 to 3.13)^[35, 43, 44]. These are not the only processes in which sulphate can be removed, but are the primary ones.

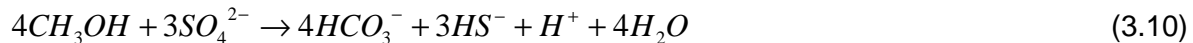
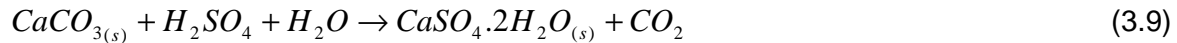

or



By observation of Table 3.6, it is possible to notice that in the winter sulphate removal rates are higher. The role of Section A (see Figure 1.15) where the metal uptake takes place is decisive for this, since in the section B (see Figure 1.15) sulphate concentration increases and in Section C (see Figure 1.15) sulphate removal is insignificant. Sulphate reduction rates are more dependent on sulphate concentration than on available organic substrate, therefore high sulphate concentrations lead to higher precipitation rates^[35, 44]. Studies referred in literature^[44] indicate that SRB can effectively remove sulphate at 6 °C but at lower temperatures SRB activity slows down. Nevertheless, different density of bacteria *consortium* could explain this high sulphate removal rates. Data also reveals a higher concentration of Ca²⁺ in Section A which could contribute to this removal percentage in the winter. Differences on plant growth visible within the wetland profiles (see Figure 3.13) could as well explain the poor results in Section C both in both winter and summer season.

Table 3.6. Seasonal variation in Sulphate removal rates.

Section	Boreholes	Winter		Summer	
		SO ₄ ²⁻ mg/L	SO ₄ ²⁻ %	SO ₄ ²⁻ mg/L	SO ₄ ²⁻ %
A	P4 - HM1	477.5	49.9	202.8	21.7
B	HM1 - HM3	9.1	0.9	239.5	25.7
C	HM3 - HM4	0.6	0.1	92.8	9.9
Total	P4 - HM4	469.0	49.1	349.5	37.7



Figure 3.13: Differences on plant growth during the growing season.

3.1.4 Modelling of Profiles

The modelling of profiles is useful to understand the wetland behaviour, concerning pollutant removal rates and to observe the parameter evolution along the wetland profile. From the collected data, it is possible to input the values into the program and run it according to the point of study. The modelling of profiles was performed using the Geochemist's Workbench software.

The water flows under the sludge bed arising in the beginning of the pond. When entering into the natural system, the water gets in contact with atmosphere and also with organic matter which creates different wetland conditions. These circumstances allow to model geochemical processes within the natural system. The first step, has been modelling flow direction along the wetland profile. In Figure 3.14 is presented the flow behaviour.

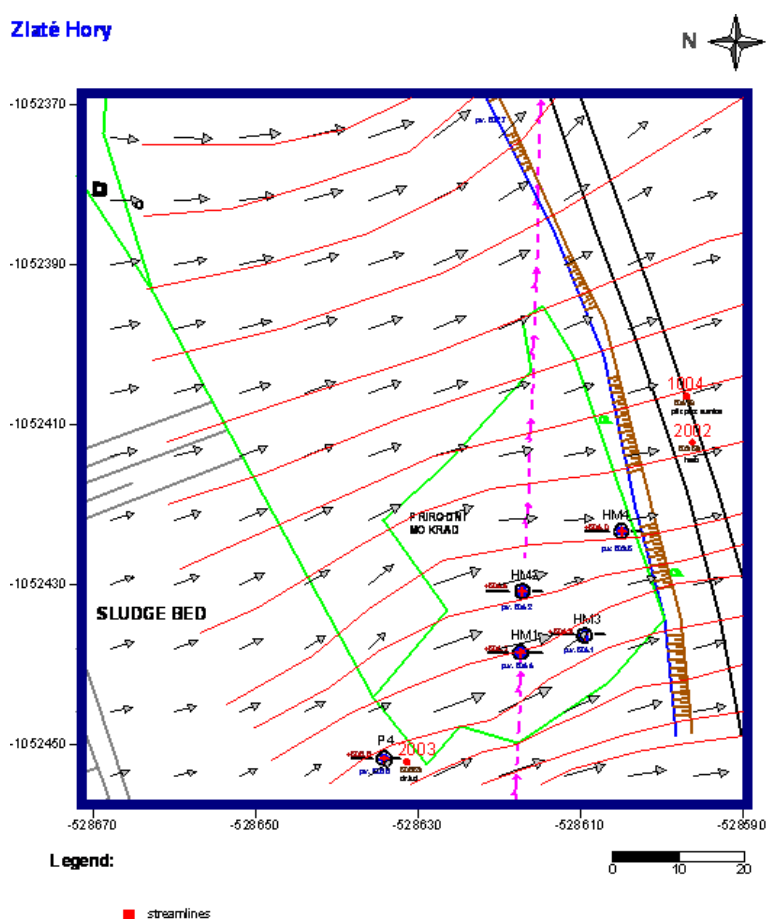

Figure 3.14: Model of flow direction in the natural wetland.

As a starting point for modelling the geochemical processes within the natural wetland, it has been taken a water sample from borehole P4, which well represent surface drainage and groundwater seepage. Model water composition is shown in Table 3.7.

Table 3.7: Model water composition representing the initial conditions in the natural wetland.

Parameter	Water Model
Temperature (°C)	7.5
pH	5.7
ORP (mV)	280.5
Mineralization (mg/L)	1435.0
Na (mg/L)	7.0
K (mg/L)	8.0
Ca (mg/L)	286.0
Mg (mg/L)	49.5
Fe (mg/L)	45*
Mn (mg/L)	16.0
HCO ₃ ⁻ (mg/L)	155*
SO ₄ ²⁻ (mg/L)	951.0
Cl ⁻ (mg/L)	7.5

* expected value before contact with the atmosphere

The water characteristics have been determined by Piper diagram (see Figure 3.15) using the collected data from the input point P4. Observing the diagram, it is possible to conclude that this water is calcium-sulphated.

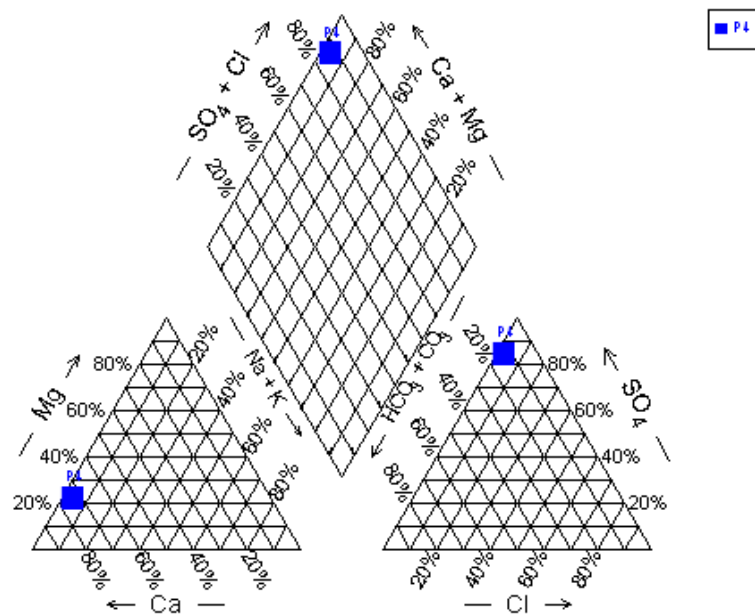

Figure 3.15: Water characteristics at P4.

Observing Figure 3.16, it is possible to visualize the evolution of pH as the reaction takes place within the longitudinal profile of the wetland. The linear evolution suggests that alkalinity is always rising along the profile due to oxidation and reduction reactions.

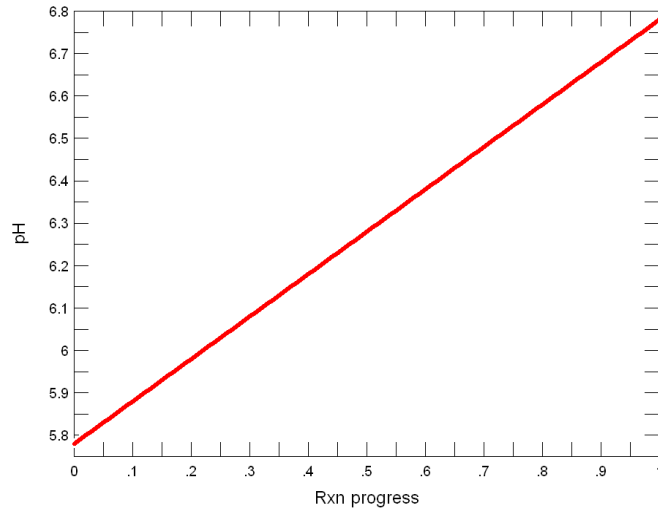

Figure 3.16: pH evolution according to reaction progress.

Analysis of Figure 3.17, suggests that in the beginning of the wetland the species are oxidized and further along the profile reduced. After, new oxidation will occur and further reduction. This conclusion is based in the two stage ORP profile shown in Figure 3.17.

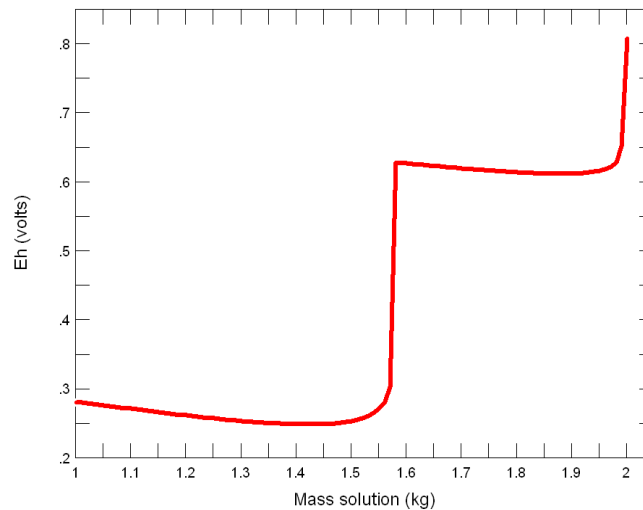

Figure 3.17: ORP dynamics along the wetland profile.

As previously mentioned both Fe^{2+} and Mn^{2+} are dependent on pH, being the Mn^{2+} specie more affected by this parameter. Figure 3.18, show the evolution of both pollutants along the longitudinal profile. Since Fe^{2+} can be oxidized at pH around 3, its removal rate is almost constant along the profile. In the Mn^{2+} case, there are two different slopes. The first is less

steep, but after a certain point the slope becomes more pronounced perhaps due to pH increase which could be enough to optimize Mn^{2+} removal rate.

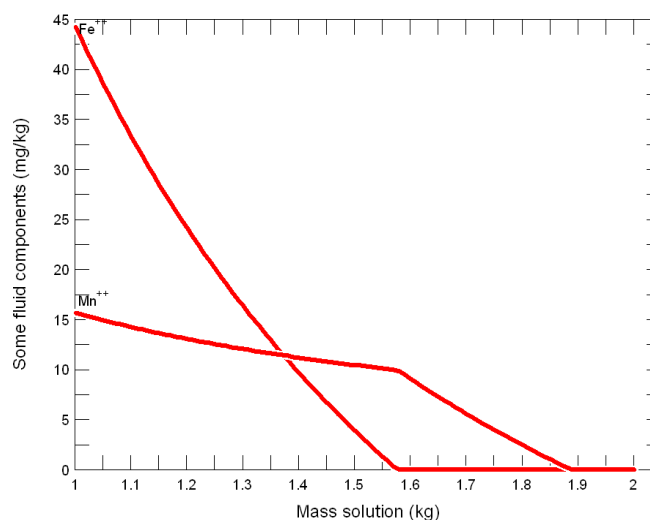

Figure 3.18: Fe^{2+} and Mn^{2+} evolution along the wetland longitudinal profile.

In conclusion, by modelling the longitudinal profiles it is possible to understand better the natural wetland dynamic regarding the pollutants and parameters tested. Nevertheless, this software can be used to test more situations within the wetland, for example, to know the mineral disposition along depth. By manipulating other variables the knowledge of processes within the wetland could benefit in further studies.

3.2 Constructed Wetland

Since in Czech Republic there was not implemented a functional remediation treatment system, engineers from Aquatest a.s., visit the Newcastle facilities in the United Kingdom to obtain the required knowledge for the implementation of this type of system in Czech Republic^[42]. In 2006, a hybrid remediation system was built with three serially arranged cells as referred in Chapter 1, Section 1.6.2.

Before present the results, it is important to make two considerations. First, mention that the water samples were collected in the output of each cell as shown in Figure 3.19. Other is related with the input point of this system. As shown in Figure 1.16, the concrete shaft (P3C) was fitted with a cast-iron lid to prevent the entrance of air into the shaft and the contaminated water was collected from a valve, thereby preventing oxidation of various components of water, especially dissolved $\text{Fe}^{[42]}$.

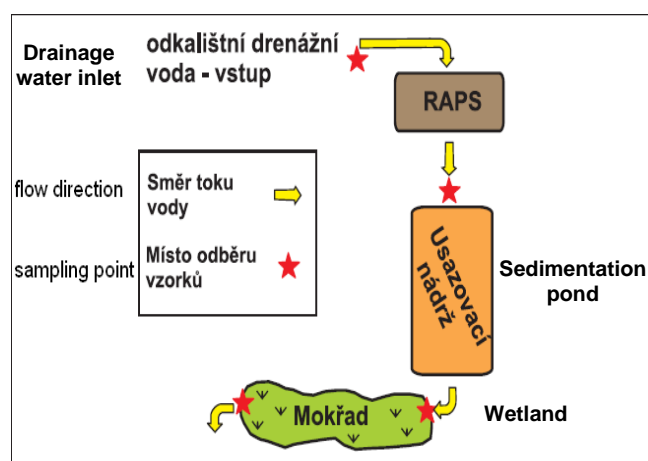

Figure 3.19: Description of sampling points in the constructed wetland^[42]

3.2.1 Long Term Observation of Outflow

This system has been built to treat Fe, Mn and sulphate, however it is more suitable to treat the iron from mine drainage water as it will be shown further. The monitored parameters were the same as referred in the natural wetland. All the presented values are based on field measurements.

The pH evaluation along time does not show a significant change along the constructed wetland cells (see Figure 3.20). By calculating the pH deviation all the values have approximately the same range. However, it was possible to measure, for example in P3C pH values of 5 and 7.3.

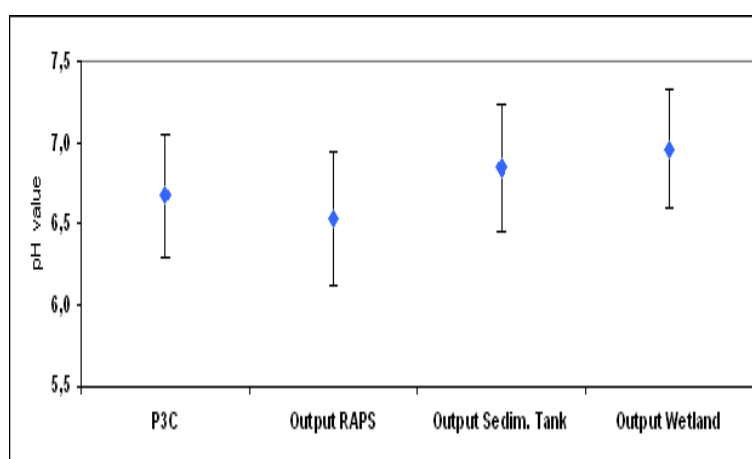

Figure 3.20: Average pH evolution over time along the constructed wetland.

3.2.1.1 Iron Removal Rates

The system provided a great efficiency regarding the Fe removal. It is even more notorious given the input of Fe concentration which has an average value of approximately 28 mg/L. It is seven times higher than the wetland input. The measurements made in the wetland output have shown an average concentration of 2.5 mg/L. Since the area of each cell is significantly smaller than the natural wetland, parameters such as temperature, DO and ORP may cause this change between measurements. The Fe removal trend decreases gradually from the beginning of the study until June 2008, but unexpectedly from August 2008 to October 2008 and from April 2009 to June 2009, the trend shows a higher dispersion of Fe concentration values (see Figure 3.21). This system, as many times referred is strongly dependent on weather conditions and on the parameters such as pH, conductivity and ORP. In order to diminish the results variability due to different periods of sampling, the measurements should be made periodically with fixed time intervals. Nevertheless, the increasing Fe concentration in all cells is consistent with higher concentration values measured in the input point (see Figure 3.21). Analysing Figure 3.22, the overall efficiency is approximately 90%, being 66% removed in RAPS.

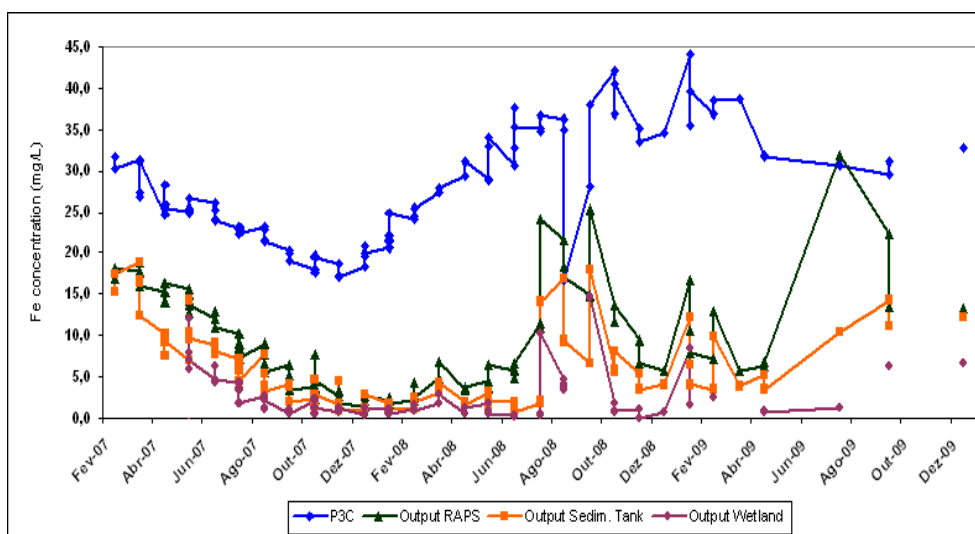

Figure 3.21: Evolution of Fe removal over time in the constructed wetland.

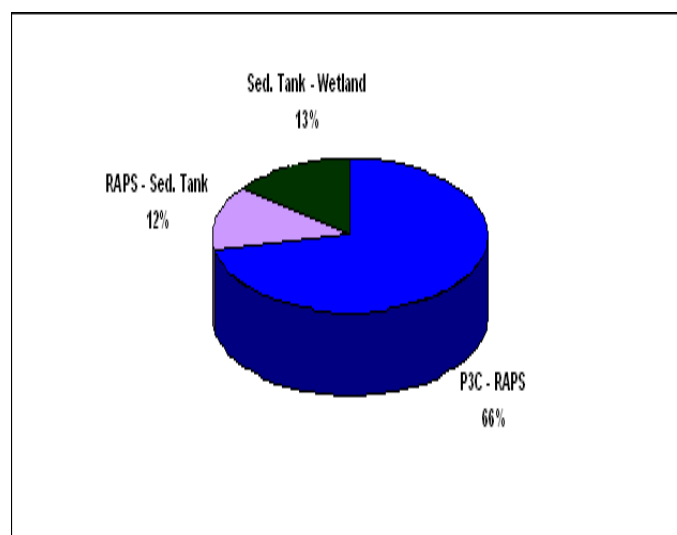

Figure 3.22: Fe removal (%) along the constructed wetland cells.

3.2.1.2 Manganese Removal Rates

Based on field measurements, the average Mn concentration in P3C is approximately 8,2 mg/L. The average concentration measured in the wetland cell output reveals a concentration of 5,5 mg/L. This evaluation shows the limitation of the pilot system, which is a common problem among these constructed remediation systems. The retained Mn over time is shown in Figure 3.23. In the first six months of the conducted analysis, the Mn trend has shown a stable baseline concerning Mn removal rates increasing after this period. The Figure 3.23 also demonstrates the inefficiency of RAPS and Sedimentation Tank in Mn retention. As referred, chemical removal of Mn occurs at pH higher than 8. Having this in consideration, it is not surprising to observe that the highest amount of Mn is retained in the wetland cell due to the presence of vegetation which allows bacterial growth and thereby increasing the Mn removal rates. The increasing of pH which in the wetland cell is approximately 7, contributes for this result.

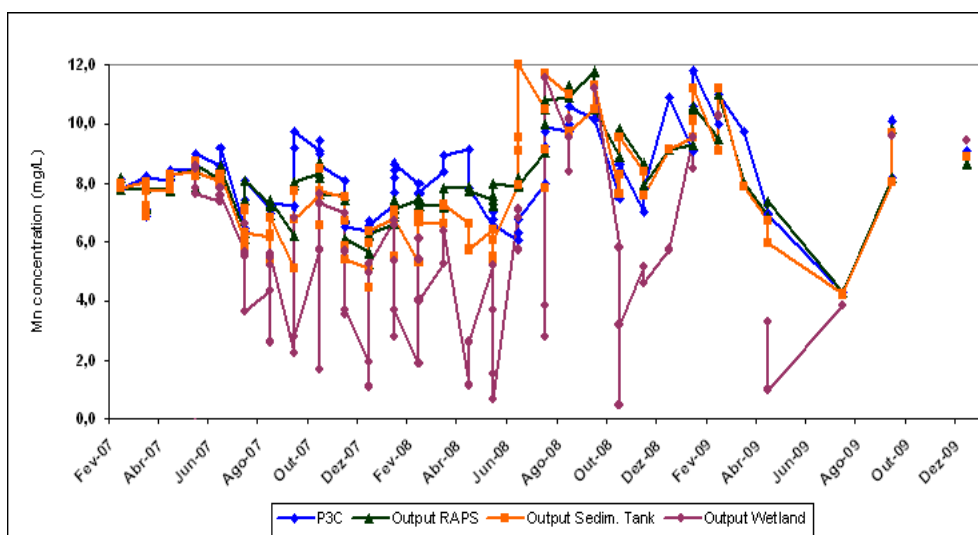

Figure 3.23: Evolution of Mn removal over time in the constructed wetland.

Observing Figure 3.24, it is visible the differences in percentage between the RAPS and Sedimentation Tank cells compared with the natural wetland cell. This last one is able to retain four times more Mn than RAPS and the sedimentation basin together, which proves the importance of this cell in the system. The results reveal 33% of efficiency for Mn removal.

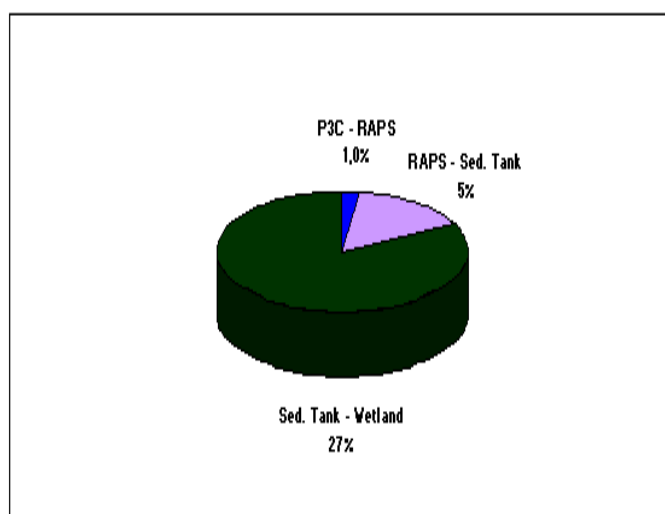

Figure 3.24: Mn removal (%) along the constructed wetland cells.

3.2.1.3 Sulphate Removal Rates

The results for sulphate removal presented in Figure 3.25 shows the low efficiency in reduce this pollutant. The collected data showed an overall concentration of 382 mg/L in P3C and 357 mg/L in the wetland output which represents approximately 7% of efficiency (see Figure 3.26). Due to this fact, understanding the natural processes within the natural wetland is extremely important. The acquired knowledge from the studies carried out in the natural wetland, could

give new perspectives of how to solve the sulphate issue in this case. Attenuation of sulphate is mainly in RAPS cell (see Figure 3.26), and it could be related with SRB activity. The biochemical activity, result in immobilization of dissolved iron as iron sulphide.

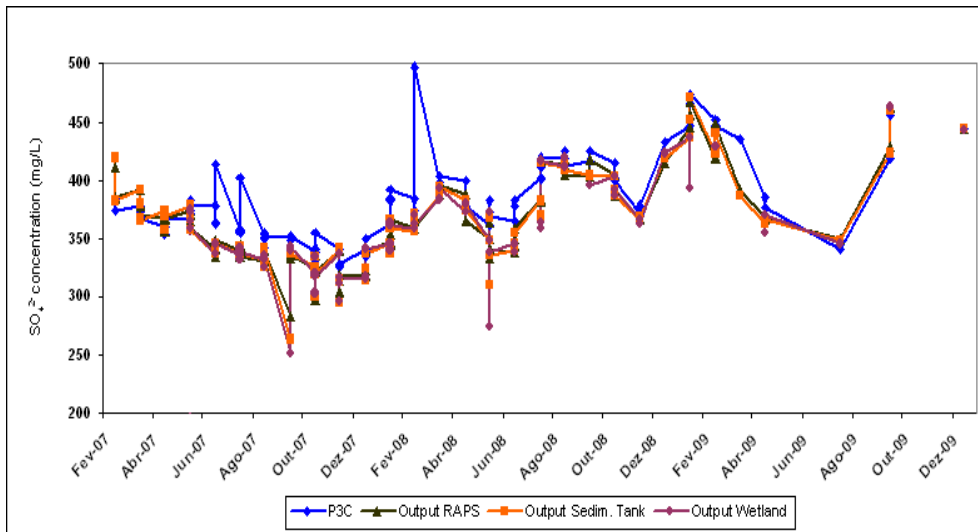

Figure 3.25: Evolution of sulphate removal over time in the constructed wetland.

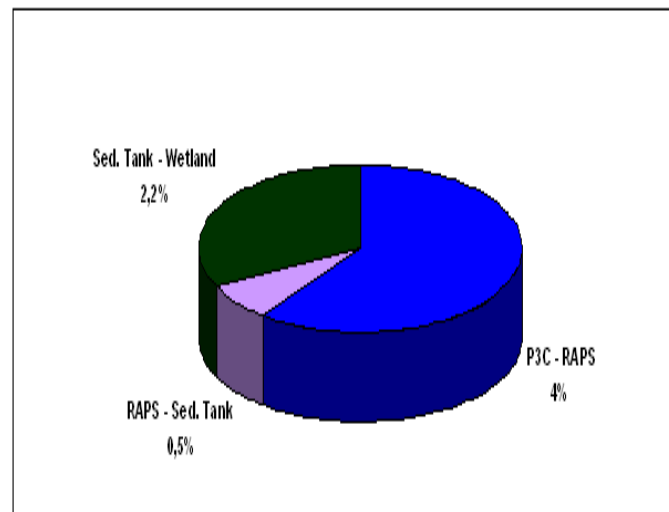

Figure 3.26: Sulphate removal (%) along the constructed wetland cells.

3.2.1.4 Seasonal Variations

To study the seasonal variations in the constructed wetland it was considered that winter months were from December to March and summer months from June to August.

Laboratory studies has showed that the rate of oxidation is reduced ten times when the temperature drops below 15 °C^[42]. However, field measurements reveal the opposite which could mean that the cold climate does not influence the system dynamics and that bacteria can promote metal oxidation even in these conditions. Based on the results shown in Table

3.7, Fe removal in RAPS cell is more efficient in winter, suggesting the adaption of *Thiobacillus Ferroxidans* bacteria to cold temperatures. Also, in the wetland cell the effect of cold climate on SRB activity can be negligible since it shown better efficiency in the considered winter months than in the summer. If bacteria can adjust to the seasonal changes of temperatures, the conditions in winter months may be even better than summer for metal removal. In the winter, the basins are covered with a thin ice crust preventing oxygen to dissolve. Nevertheless, the differences in DO in winter and summer are not significant. Having this in consideration and since solubility of oxygen in water increases at low temperatures, the oxidation can be more effective. During the melting season (April and sometimes May), the water flow increases throughout the system. It can cause leaching of oxidized metals and established precipitates. Cold temperatures can also provide a positive effect in the physical conditions of the basins. For example, the ice covering the sedimentation tank reduces the influence of turbulence caused by wind. In addition, snow act as a coating retaining the heat in the basin promoting the chemical and biological reactions at an acceptable level during the winter. Reference to the negative Mn values in the summer study which are related with a sequence of measurements made between July and August of 2008.

Table 3.8: Seasonal variations of all major pollutants.

Section	Winter						Summer					
	Fe	Fe	Mn	Mn	SO ₄ ²⁻	SO ₄ ²⁻	Fe	Fe	Mn	Mn	SO ₄ ²⁻	SO ₄ ²⁻
	mg/L	%	mg/L	%	mg/L	%	mg/L	%	mg/L	%	mg/L	%
P3C - RAPS	20.4	72.0	0.6	7.0	13.8	3.5	16.4	58.7	-0.5	-5.8	21.2	5.6
RAPS - Sed. Tank	1.7	5.9	0.3	3.5	2.1	0.5	5.3	19.1	0.2	2.2	1.9	0.5
Sed. Tank - Wetland	4.5	15.8	1.9	23.2	11.6	2.9	3.2	11.4	1.8	23.2	2.5	0.6
P3C - Wetland	26.6	93.7	2.8	33.7	27.5	6.9	24.9	89.2	1.5	19.5	25.6	6.8

3.2.2 Comparison Between the Natural and the Constructed Wetland

A direct comparison between the natural and the constructed wetland is not easy to make given the initial pollutant concentration in both cases (see Table 3.9), size of system site and bioremediation processes. The series of processes which allows metal to be removed/reduced in both systems do not have the same sequence. In the natural wetland the Fe removal process is oxidation, followed by reduction and in the pilot system, first is Fe reduction in the RAPS and after Fe oxidation in the sedimentation and wetland tank. In the natural wetland Mn is first precipitate and then reduced. In the pilot system precipitation and oxidation occurs together in the sedimentation tank followed by oxidation and precipitation in the wetland cell. Sulphates precipitate in the natural wetland and in the constructed wetland it is reduced in RAPS cell. The water genesis is also different in both cases. In the natural wetland the water arises to the surface probably from the deepest and oldest layers of the mine. The water source which flows to the artificial system comes from drainage water. This drainage water is a mixture between lower mineralized water produced by infiltration in the western part of the sludge bed with water contained in the sludge bed. From observation of Table 3.9 it is possible to say that both systems are efficient for Fe removal, being the differences between removal rates insignificant, although in the case of manganese and sulphate the natural wetland achieves better results.

Table 3.9: Comparison between the natural and the constructed wetland.

Section	Boreholes	2007 - 2009								Section	2007 - 2009					
		Fe ²⁺ (mg/L)	Fe ³⁺ (%)	Fe (mg/L)	Fe (%)	Mn (mg/L)	Mn (%)	SO ₄ ²⁻ (mg/L)	SO ₄ ²⁻ (%)		Fe (mg/L)	Fe (%)	Mn (mg/L)	Mn (%)	SO ₄ ²⁻ (mg/L)	SO ₄ ²⁻ (%)
	P4	4.1		4.6		14.6		951		P3C	27.7		8.14		382	
A	P4 - HM1	1.7	42.5	1.5	33.0	11.6	80.0	382.7	40.2	P3C - RAPS	18.2	65.6	0.1	0.8	15.3	4.0
B	HM1 - HM3	1.9	46.0	2.3	49.5	0.3	2.0	76.3	8.0	RAPS - Sed. Pond	3.4	12.3	0.4	4.9	1.7	0.5
C	HM3 - HM4	0.5	11.0	0.7	14.5	2.6	18.0	-23.7	-2.5	Sed. Pond - Wetld.	3.6	12.9	2.2	26.7	8.3	2.2
Total	P4 - HM4	4.1	99.5	4.5	97.0	14.5	100.0	435.3	45.8	P3C - Wetld.	25.2	90.9	2.7	32.4	25.3	6.7

4: Conclusions and Future Work

4.1 Conclusions

The construction of passive systems involves prior studies of the water quality, genesis and seasonal variations. The water flow is also important to sizing criteria decisions. The constructed wetland proved to be efficient for Fe removal, which is the main purpose of this type of systems, but its limitation regarding manganese and sulphate removal was evident. While the system could remove approximately 90% of the incoming Fe concentration, the results of Mn and sulphate removal were 33% and 7% respectively. Nevertheless, if the treatment relied only on Fe treatment, it could be said that this remediation system is suitable for application in other mining sites given the higher input concentration compared with the natural wetland. As an example, this 90% removal correspond in practice 79,5 ton.y⁻¹ of Fe retained by the system. In addition, the low maintenance and implementation costs make these passive systems an important technology to treat contaminated water, not only mine water but also wastewaters.

Regarding the natural wetland, the system proved to be very effective to treat acid mine drainage. Data has showed an efficiency of 100% in Fe and Mn removal and 45% in sulphate, which is equivalent to approximately 800 ton.y⁻¹ of sulphate retention. The natural processes occurring within the natural wetland are not completely understood. Thereby, biological processes involving metal uptake by bacteria as well as the role of vegetation should be considered in further studies.

As opposed to what was expected, seasonal variations in both cases did not affect significantly the removal rates. Thereby, it can be concluded that certain bacteria could be active at lower temperatures and therefore, the winter season could provide better conditions for metal removal. For example, the ice covering the sedimentation tank reduces the influence of turbulence caused by wind. The same principle can be applied to the natural wetland. In addition, snow act as a coating retaining the heat in the basin promoting the chemical and biological reactions at an acceptable level during the winter.

Since soil studies started in 2010, conclusions based on soil profile are expected to be achieved in the near future.

Summarizing, the application of the passive system to treat contaminated mine water and possible wastewater seems to be a solution for such environmental issues. In addition, the possibility to implement these systems, for example, on city parks and transforming them in leisure spaces corroborate the ongoing studies performed throughout the world.

4.2 Future Work

One limitation of the constructed wetland is the absence of a flushing system in RAPS tank. The initial project did not considerate this hypothesis due to implementation costs. To overcome this situation four drainage pipes were installed, which are not adequate for the system. Most of the times it is necessary to regulate the water flow since the pipes clogged due to excessive iron concentration.

One of the major goals could be the optimization of sulphate removal rates, since is not accomplished in any other treatment facility similar to this one.

In the natural wetland, besides the ongoing studies of the soil profile and characteristics should be determinate with accuracy the water flow paths. Once determined, the installation of probes along the horizontal profile separated with equal distances should be performed. If one of the sections proved to be more efficient, detailed studies of that section should be done. Also, it is important to understand why bacteria activity seems to be effective in winter.

References

- [1] – Younger, P, Banwart, S and Hedin, R, 2002. *Mine Water: Hydrology, Pollution, Remediation*. Springer, 442pp.
- [2] – Lottermoser, B, 2007. *Mine Wastes: Characterization, Treatment, Environmental Impacts*. Springer, 2nd ed., 320pp.
- [3] – Fonsaca, Hersilia. 2004. Mining: Social and Environmental Impacts. Montevideo: World Rainforest Movement. Publication number 9974-7782-6-3. (PDF version downloaded on April 20, 2010)
- [4] – *Safety of Tailing Dams*. August 21, 2004. <http://www.wise-uranium.org/mdas.html> (accessed on April 20, 2010)
- [5] – GDACE Mining and Environmental Impact Guide – Environmental Impacts Associated with Mining Operations and Mineral Extraction Processes (chapter 9). (PDF version downloaded on May 4, 2010).
- [6] – Aswathanarayana, U, 2003. *Mineral Resources Management and the Environment*. Taylor & Francis, 313pp.
- [7] – Hudson, T, Fox, F and Plumbee, G, 1999. *Metal Mining and the Environment*. American Geological Institute, 66pp.
- [8] – Ghose, M, 2004. Effects on Opencast Mining on Soil Fertility. *Journal of Scientific & Industrial Research*, 63: 1006-1009
- [9] – Cottard, F, 2001. Potential Environmental Impacts of Mining – A Short Illustrated Review. Vienna, Austria. (PDF version downloaded on May 4, 2010).
- [10] – Costello, C, 2003. Acid Mine Drainage: Innovative Treatment Technologies. USEPA, Office of Solid Waste and Emergency Response, Washington DC.
- [11] – Pennsylvania, Department of Environmental Protection. “*What is Mine Subsidence?*”. <http://www.dep.state.pa.us/MSI/whatisms.html#troughsinkpics> (accessed on May 7, 2010)

- [12] – McGuinness, Stephen. 1999. Treatment of Acid Mine Drainage. Science and Environmental Section, House of Commons Library. Research paper 99/10 (PDF version downloaded on March 7, 2010).
- [13] – Eisler, R, 2004. *Biogeochemical, Health, and Ecotoxicological Perspectives on Gold and Gold Mining*. CRC Press, 376pp.
- [14] – Gazea, B, Adam, K and Kontopoulos, A, 1996. A review of passive systems for the treatment of acid mine drainage. *Minerals Engineering*, 9 (1): 23-42.
- [15] – PIRAMID Consortium, 2003. *Passive In Situ Remediation of Acidic Mine/ Industrial Drainage*. EUGRIS: Portal for Soil and Water Management in Europe.
- [16] – Diz, H, 1997. *Chemical and Biological Treatment of Acid Mine Drainage for the Removal of Heavy Metals and Acidity*. PhD thesis in Civil Engineering. Faculty of the Virginia Polytechnic Institute and State University. 89pp.
- [17] – CL:AIRE, 2002. *A Constructed Wetland to Treat Acid Mine Drainage from Colliery Spoils at Quaking Houses, County Durham – Case Study Bulletin*, Abandoned Mine Lands. USEPA.
- [18] – Ford, KL. 2003. *Passive Treatment Systems for Acid Mine Drainage*. Technical Note 409. BLM/ST/ST-02/001+3596. Bureau of Land Management. USEPA
<http://www.blm.gov/nstc/library/techno2.htm>.
- [19] – White, S. Wetland Use in Acid Mine Drainage Remediation. (PDF version downloaded on July 6, 2010)
- [20] – Kalin, M, Fyson, A and Wheeler, W. 2006. The chemistry of conventional and alternative treatment systems for the neutralization of acid mine drainage. *Science of the Total Environment*, 366 (2-3): 395-408.
- [21] – Wilkin, R. United States Environmental Protection Agency. “Metal Attenuation Processes at Mining Sites”. <http://www.epa.gov/nrmrl/pubs/600r07092/600R07092.pdf>. (PDF version downloaded on June 20, 2010).
- [22] – Aubé, B and Zinck, J. 2003. Lime Treatment of Acid Mine Drainage in Canada. Florianópolis, Brazil. (PDF version downloaded on March 7, 2010).

- [23] – Johnson, D and Hallberg, K, 2005. Acid mine drainage remediation options: a review. *Science of the Total Environment*, 338 (1-2): 3-14.
- [24] – Watzlaf *et al.* 2004. The Passive Treatment of Coal Mine Drainage. DOE/NETL-2004/1202.
- [25] – Berghorn, G and Hunzeker, G. 2001. Passive Treatment Alternatives for Remediating Abandoned Mine Drainage. John Wiley & Sons, Inc.
- [26] - Pennsylvania, Department of Environmental Protection. “*The Science of Acid Mine Drainage and Passive Treatment*”.
http://www.dep.state.pa.us/dep/depuate/minres/bamr/amd/science_of_am.htm (accessed on Feb 26, 2010).
- [27] – Schmidt, K, 2002. Passive Treatment Methods for Acid Water in Pennsylvania. College of Agricultural Sciences - The Pennsylvania State University.
- [28] – Hedin, R. 2008. Iron Removal by a Passive System Treating Alkaline Coal Mine Drainage. Springer. DOI 10.1007/s10230-008-0041-9. (PDF version downloaded on June 22, 2010).
- [29] – Demchak, J, Morrow, T and Skousen, J, 2001. Treatment of acid mine drainage by four vertical flow wetlands in Pennsylvania. *Geological Society of London*, 1 (1): 71-80
- [30] – Bufka *et al.* “*Historical subsurface mining works in the Czech Republic as technical monuments*”. July 23, 2007. <http://www.velebil.net/en/czech-mines/>. (accessed March 8, 2010)
- [31] - <http://www.montanya.org/> (accessed March 9, 2010)
- [32] – Baltic Balkan Travel Group. http://baltic-balkantours.com/en/travels/1/the_czech_republic/27 (accessed July 13, 2010)
- [33] – Novotný, P, Zimák and J. “*Zlaté Hory - Historie a současnost ložiska zlata evropského významu*”. 1st ed., 2003. <http://www.hornictvi.info/cteni/zhory/13.htm>. (accessed March 8, 2010).

- [34] – Campbell, CS and Ogden, M, 1999. *Constructed Wetlands in the Sustainable Landscape*. John Wiley & Sons, Inc, 288pp.
- [35] – Reddy, KR and DeLaune, RD, 2008. *Biogeochemistry of Wetlands: Science and Applications*. CRC Press, Taylor & Francis Group, 774pp.
- [36] – Smith, D and Moore, JA, 2006. *Understanding Natural Wetlands*. Oregon State University.
- [37] – Gelt, J. *Constructed Wetlands: Using Human Ingenuity, Natural Processes to Treat Water, Build Habitat*. March 1997. <http://ag.arizona.edu/azwater/arroyo/094wet.html> (accessed July 20, 2010).
- [38] – www.mapy.cz (accessed July 16, 2010)
- [39] – ČSN EN 25 667-2: 1994. Water quality – guidance on sampling of drinking water and used for food and beverage processing, part 5.
- [40] – ČSN EN ISO 5667-3: 1991. Water quality – guidance for preserving samples and handling, part 3.
- [41] - ČSN ISO 5667-11: 1991. Water quality - guidance on groundwater sampling, part 11.
- [42] – Černík, M, *et al.* 2008. *Geochemie a remediace důlních vod*. Aquatest a. s., 252pp.
- [43] – International Network for Acid Prevention. 2003. *Treatment of Sulphates in Mine Effluents*. Lorax Environmental. (PDF version downloaded on July 3, 2010).
- [44] – Doshi, S. 2006. *Bioremediation of Acid Mine Drainage Using Sulphate-Reducing Bacteria*. (PDF version downloaded on July 20, 2010)

Appendix A

Information on water management at the state company DIAMO s.p.s´ in 2005

➤ At the SAP Ostrava branch, the contractor AQUATEST, s.p. made two pilot attempts at cleaning up a saturated zone; data processing for models was completed; a draft implementation project was completed and 'protective pumping' was taken over and put into operation.

Appendix B

Zlaté Hory site plant

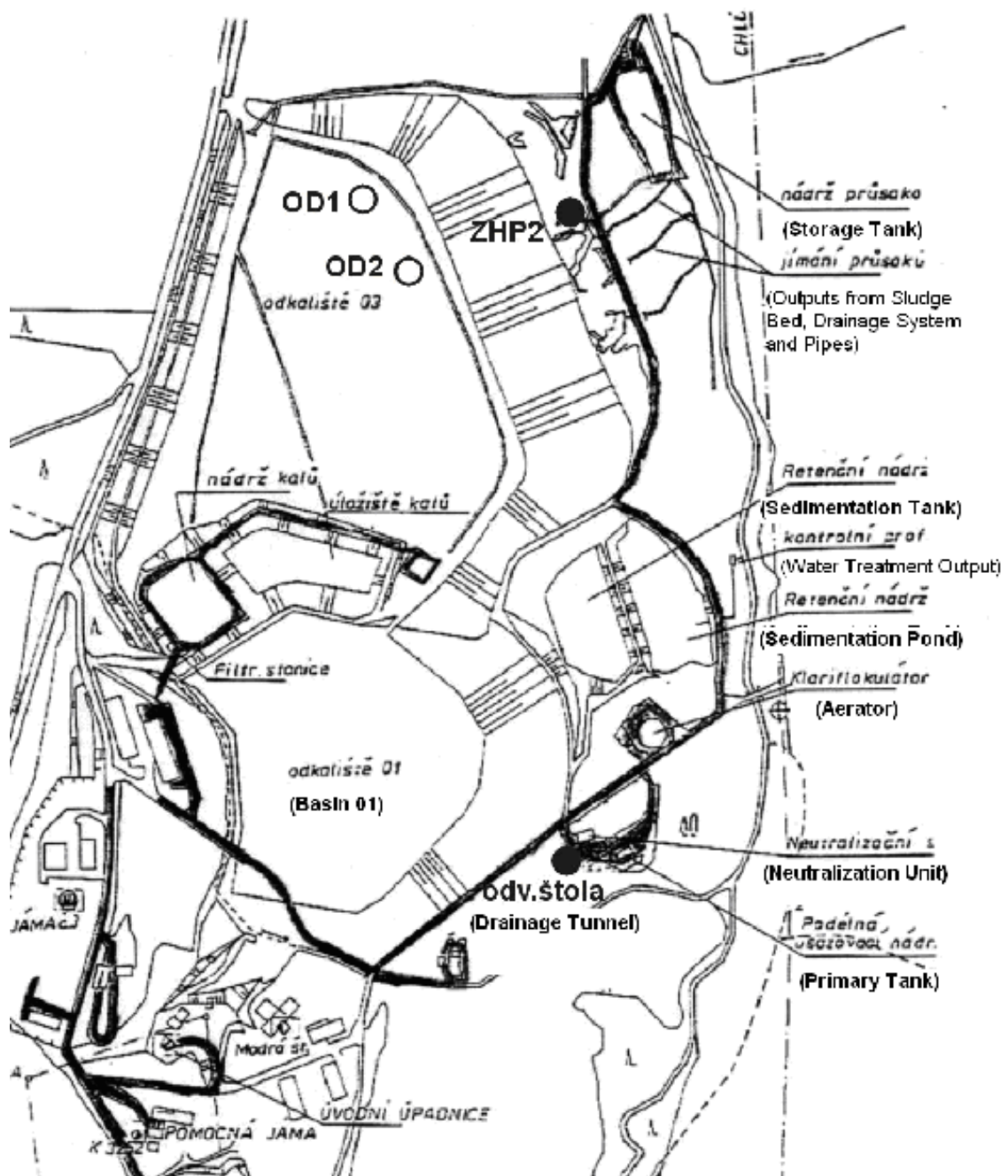

Figure B.1: Zlaté Hory site plant.

Appendix C

Selection criteria for Acid Mine Drainage treatment

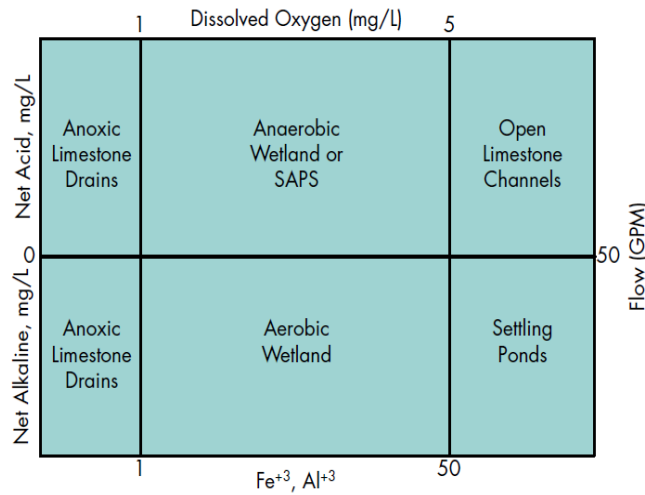

Figure C.1: Design criteria of remediation technologies based on the water parameters^[18].

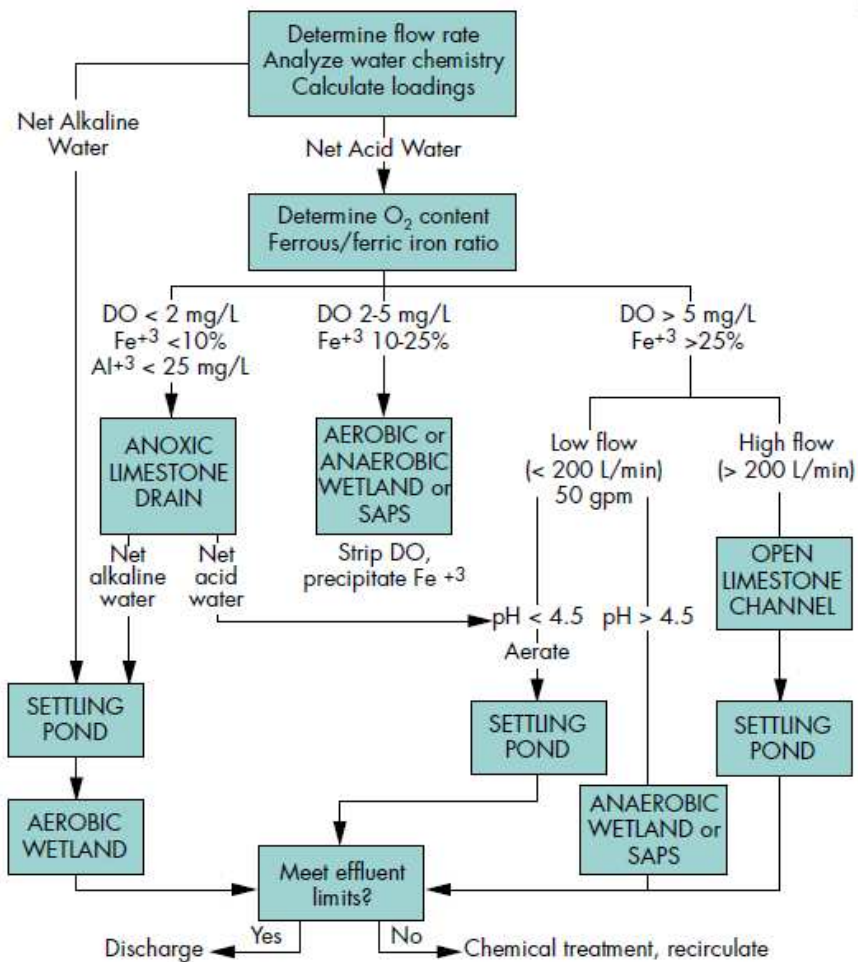

Figure C.2: Flowchart for passive treatment decision based on water chemistry and flow^[18].