

Adriano A. Santos, António F. da Silva  
 Research Center of Mechanical Engineering (CIDEM), School of Engineering  
 Polytechnic of Porto, (ISEP) Porto, Portugal  
 ads@isep.ipp.pt afs@isep.ipp.pt

# Karnaugh maps approach to understanding control implementation behind digital pneumatics

## 2.ª Parte

### IV. IMPLEMENTING CONTROL FROM KARNAUGH MAPS

At this point, the control of the study case is presented in the form of electrical pneumatic control (relay technology), a pure pneumatic control and an electro pneumatic control made in Ladder Logical diagram under a programmable logical controller.

### C. Electro pneumatic control, relay technology

Implementing electro-pneumatic circuits it is based in two fundamental parts, the power part (pneumatic action made by the actuators, -MM) and an electromechanical part which is controlled by electrical signals (directional control valve, -QM), solenoid coils (-MB), and electrical part composed by electrical signal of the limit switch (-BG) of the actuators also contacts and relays (-KF). This signal, in a binary or digital form, control the evolution of the sequence in function of signals coming from the process as well as the past and present states. Then, the minimized equations obtained from the KM's will be summarized as a set of input and outputs signals associate with more than one movement of a cylinder over the different cycles, so these final equations are combined to a sum of products. Electric scheme of this complex double-path sequence consist of a set of a serial, parallel or memory components resulting from the transcription, to a contact diagram, of the logical equations obtained from the KM's.

It is important now to present, in summary, the newer convention used to identifying the components in the electro-pneumatic circuit diagrams. So, according to the standard EN 81346-2:2009-10 [10], pneumatic part, the standard define each

component (except cables and connections) according to the code shown in Figure 11.

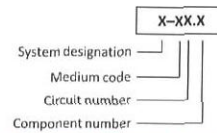

Figure 11. Designation code for components to EN 81346-2:2009-10.

Where *system designation*, define by a number or letter, can be omitted if the entire circuit consists of a single system (in the case is P, Pneumatics) and *medium code*, is a letter followed by the *circuit number* (number, absolutely necessary, followed by a full stop), followed directly by the *component number* (number). Therefore, an identifier and a number assign each component in the circuit diagram. So, within a circuit, components with the same identifier are numbered consecutively from bottom to top and left to right. Figure 12 shows electric scheme, using the new code [10][9], implementation of logical equations obtained and, as well, the memory associated to push-buttons (-SF1 and -SF2).

### D. Pneumatic control

Implementing pure pneumatic circuits it is based also in the power part (pneumatic action) and a mechanical part, which is controlled by pneumatic signals (actuation of the directional control valve). The great difference it is at the level of the control since the logical combinations are realized with pneumatic valves in detriment of the electrical contacts or of a control by a programmable logical controller (PLC). Note however, that

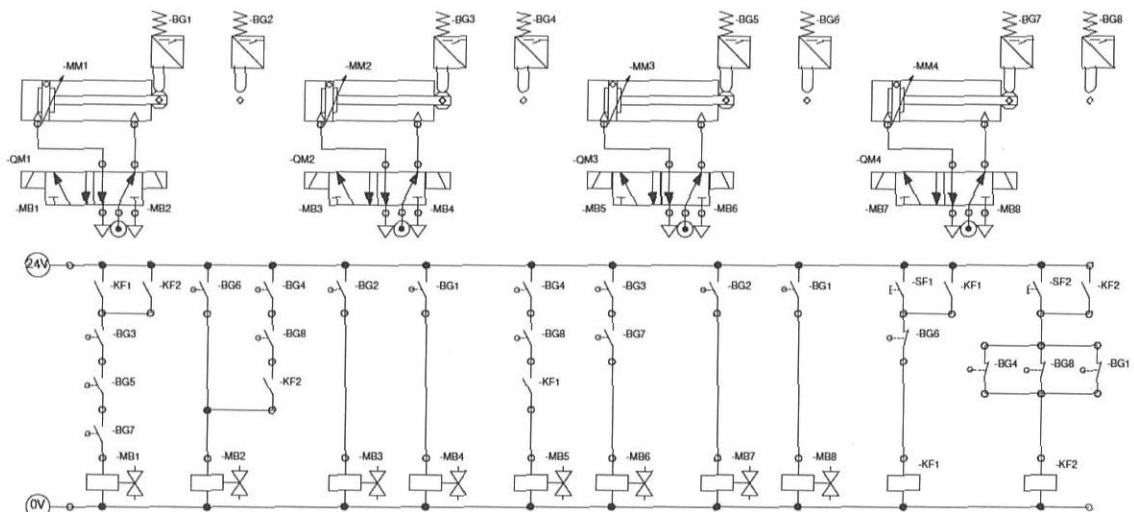

Figure 12. Electro-pneumatic control system for complex double-path sequence (S1 and S2), components identified as per EN 81346-2:2009-10.

the memory is performed with a pneumatic valve 5/2, will always maintain, by default, a signal corresponding to sequence 1 (pneumatic signal S1) or sequence 2 (pneumatic signal S2). These signals will always be present along each of the paths as can be deduced from the scheme shown in Figure 13.

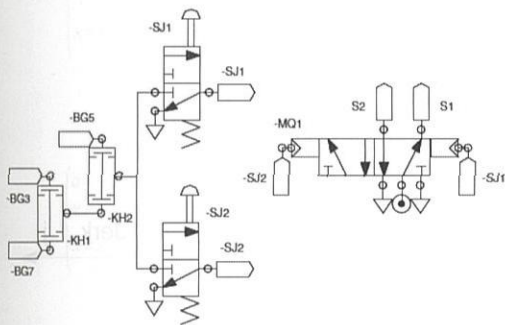

Figure 13. Memory implementation in a pure pneumatic system.

### E. PLC control

Implementing electro-pneumatic control systems is also based in two fundamental parts; the power part (control and actuation of the cylinders) and the electrical part (digital logic control by a PLC). Program control was made in Ladder Logic, using a S7-200 PLC from SIEMENS. As we can see in Figure 14, the implementation in Ladder Diagram language is a pure translation of the logical equations obtained by the KM's (translation to Ladder of the electrical scheme of Figure 12).

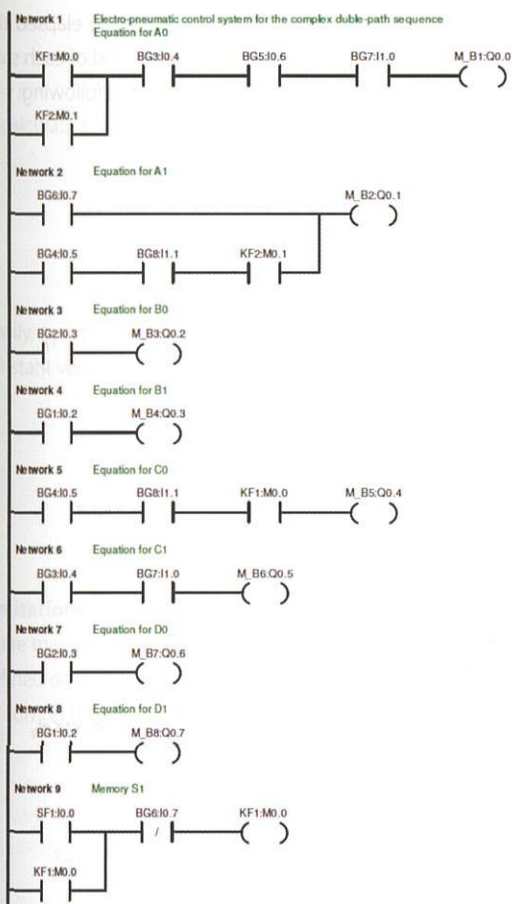

Figure 14. Digital control of an electro-pneumatic system.

### V. CONCLUSIONS

The global market imposes ever-shorter productive times for the industrial sector. Therefore, changing systems will have to be

more dynamic and capable of responding more effectively to the needs of changing the production chain. In this context, start-up and process change times become a factor of competitiveness with an impact on production and, consequently, on final gains. Purely pneumatic-based automation systems are static systems for which simply changing a movement of a pneumatic cylinder results in the physical alteration of the entire control, i.e., a lengthy process of reconstruction of all the control system.

In order to minimize start-up times, we present a methodology for defining the control system based on Karnaugh Maps adapted to industrial, pneumatic or electro-pneumatic circuits, used in a combinatorial or sequential cycle. The use of this methodology allows solving a high complexity control problem as well as the possibility of combining more than one sequence of movements in a single command. The command from logic equations obtained by the KM's ensure not only the realization of this double-path sequence, but also the minimization of the command variables required to control digital circuits.

It was also your intended to show that the control base on the equations obtained are easily converted into electrical commands. Its transformation into Ladder Diagram language is also easy to apply, opening a wide range of possibilities for industrial use, simulation of processes as well, as teaching and learning of the control of pneumatic and electro-pneumatic systems.

### ACKNOWLEDGMENT

We acknowledge the financial support of CIDEM, R&D unit funded by the FCT – Portuguese Foundation for the Development of Science and Technology, Ministry of Science, Technology and Higher Education, under the Project UID/EMS/0615/2016.

### REFERENCES

- [1] Santos, A.A. and Silva, A.F., *Automação Pneumática*, 3<sup>rd</sup> ed., Publindústria, Portugal, 2014, pp. 185-243.
- [2] Santos, A.A. and da Silva, A.F., *Methodology for manipulation of Karnaugh maps designing for pneumatic sequential logic circuits*, in International Journal of Mechatronics and Automation, Vol. 6, No. 1, pp.46-54, 2017.
- [3] Silva, A.F. and Santos, A.A., *Teaching control pneumatic and electro-pneumatic circuits – a new method*, in International Congress on Education, Innovation and Learning Technologies (ICEILT2015), September 2015, Granada, Spain.
- [4] Santos, A.A. and Silva, A.F., *Electro pneumatic control versus grafset*, in International Congress on Education, Innovation and Learning Technologies (ICEILT2015), September 2015, Granada, Spain.
- [5] Karnaugh, M., *The map method for synthesis of combinational logic circuits*, in Transactions of the American Institute of Electrical Engineers, Vol. 72, N.º 1, pp.593-599, 1953.
- [6] Sim, S-K. and Chua, P.S.K., *Symbolic pattern manipulation of Karnaugh-Veitch maps for pneumatic circuits*, in Artificial Intelligence in Engineering, Vol. 10, N.º 1, pp.71-83, 1996.
- [7] Werner, D. and Kurt, S., *Reduction des coûts par la pneumatique*, 1<sup>st</sup> ed., Vogel-Buchverlag, 1989, pp. 238.
- [8] Quickstepper FSS – FESTO (2018). [Accessed 27 mar. 19]. [One line] [https://www.festo.com/net/SupportPortal/Files/12208/PSI\\_810\\_1\\_en.pdf](https://www.festo.com/net/SupportPortal/Files/12208/PSI_810_1_en.pdf).
- [9] ISO 1219-2:2012. *Fluid power systems and components – Graphical symbols and circuit diagrams – Part 2: Circuit diagrams*. International Organization for Standardization, 2012.
- [10] IEC 81346-2:2009. *Industrial systems, installations and equipment and industrial products – Structuring principles and reference designations – Part 2: Classification of objects and codes for classes*. International Organization for Standardization, 2009. \*†