

ONLINE

# INSTEAD

VII WORKSHOP ON INNOVATIVE TEACHING  
METHODOLOGIES FOR MATH COURSES  
ON ENGINEERING DEGREES

JULY 5, 2021

isep Instituto Superior de  
Engenharia do Porto

P.PORTO

## Hands-on and Remote Lab in an Engineering Statistics Course

Marcelo Zannin



Natércia Lima

P.PORTO

isep

Instituto Superior de  
Engenharia do Porto



Carla M.A. Pinto

P.PORTO

isep

Instituto Superior de  
Engenharia do Porto



CENTRO DE  
MATEMÁTICA  
UNIVERSIDADE DO PORTO



# Introduction

What we did

Why we did it

# Where were the students from?



72 hours - theory  
18 weeks



2 editions  
84 enrolled students



Computer Engineering



Energy Engineering

# Learning Objectives and Assessment

- Descriptive Statistics



9 Tasks

Exam 1

Exam 2

- Probability Theory

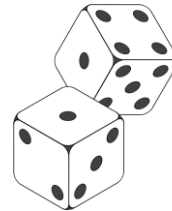

1/3

1/3

1/3

- Statistical Inference



# We proposed two problems to the students



*Is the resistance provided by the manufacturer reliable?*

*How does it behave in a real electric circuit?*

# Phase 1 – What did students do?

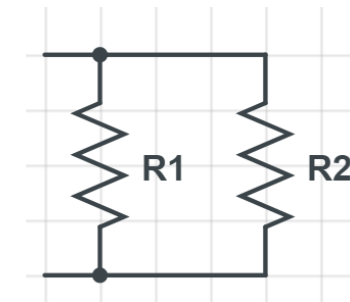
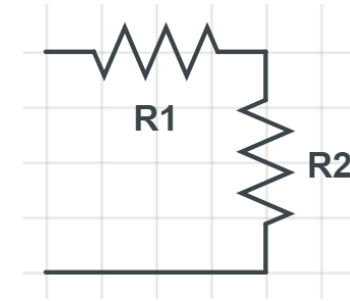
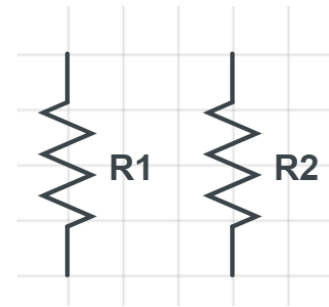

# What were they expected to do and learn?

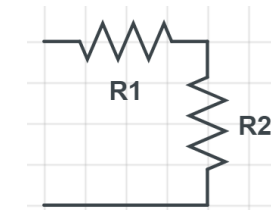
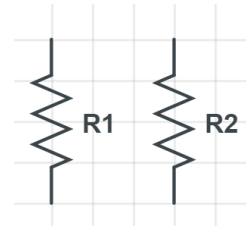
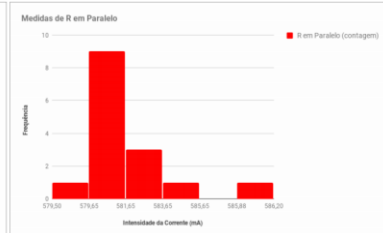
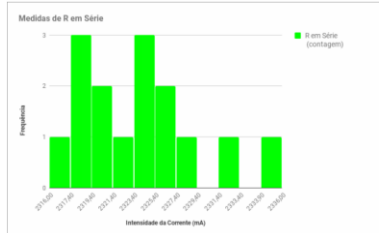
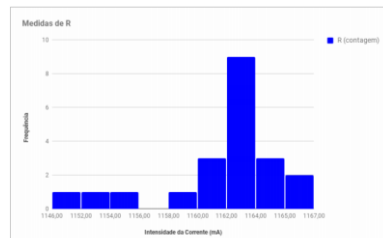
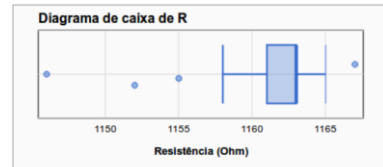

$2 \times$

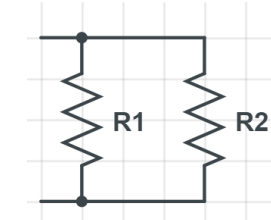

$\frac{1}{2} \times$

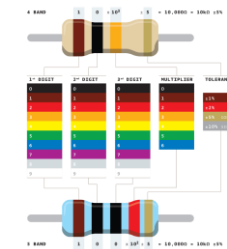

# Phase 2 – What did students do?

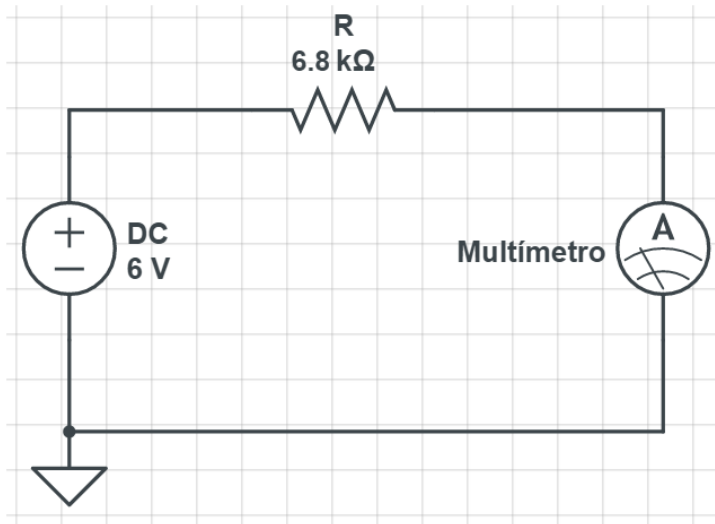

# Phase 2 – What did students do?

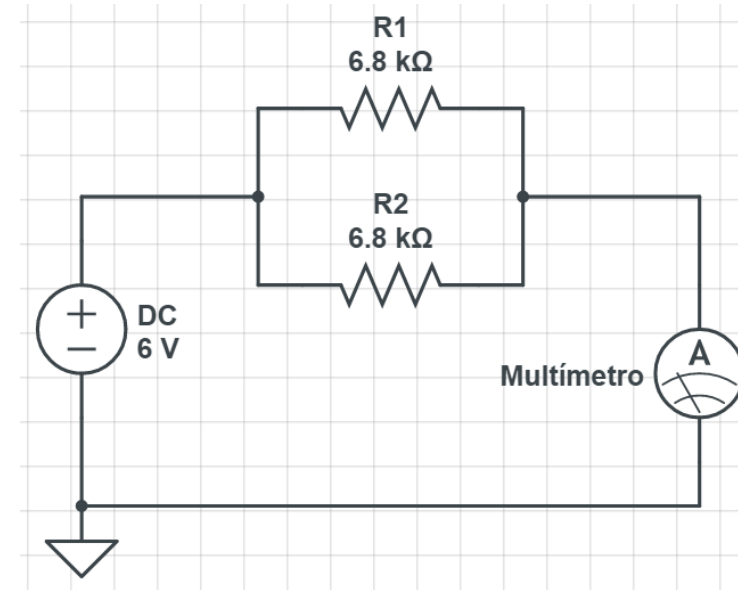
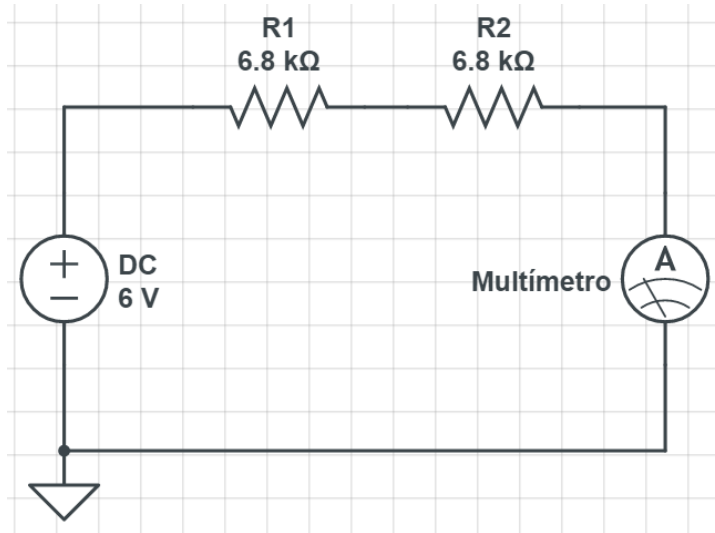

# What were they expected to do and learn?

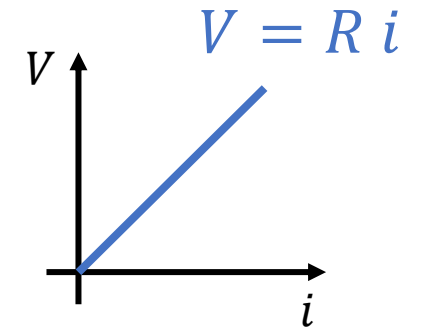
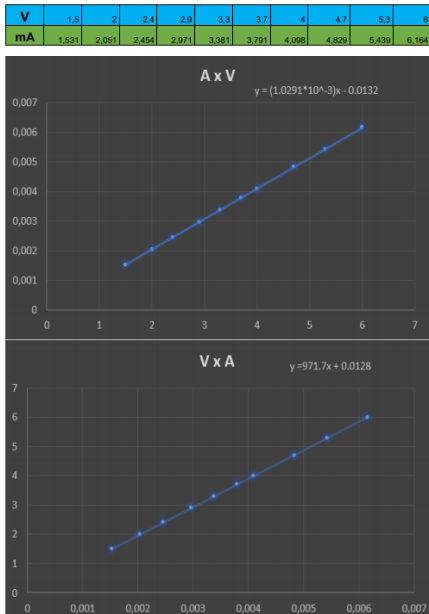

Ohm's Law



# Research question

*What are the effects of the use of hands-on and remote lab with an inquiry-based approach on statistics students?*

How we tried to answer it?

Assessment results

Attendance

Accesses to the remote lab

Student Satisfaction Questionnaire

Teacher Satisfaction Questionnaire

# Results – Student Satisfaction Questionnaire

## Students' autonomous work

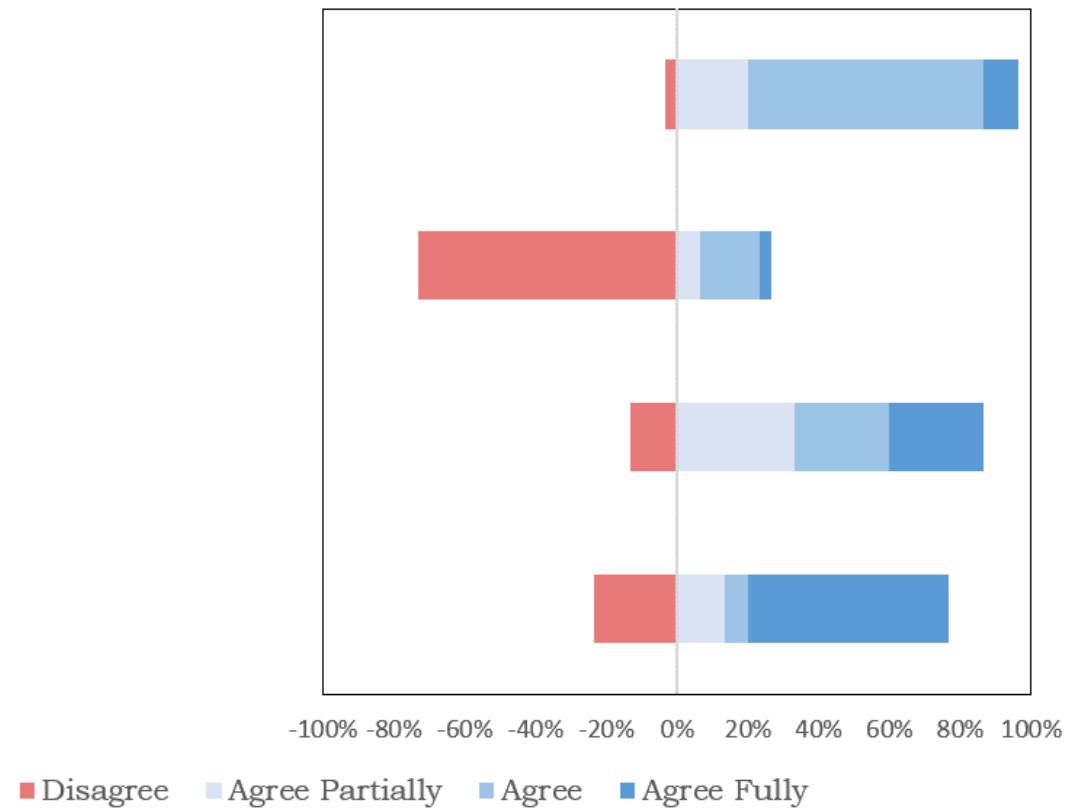

# Results – Student Satisfaction Questionnaire

## Students' development of practical, experimental and reflexive skills

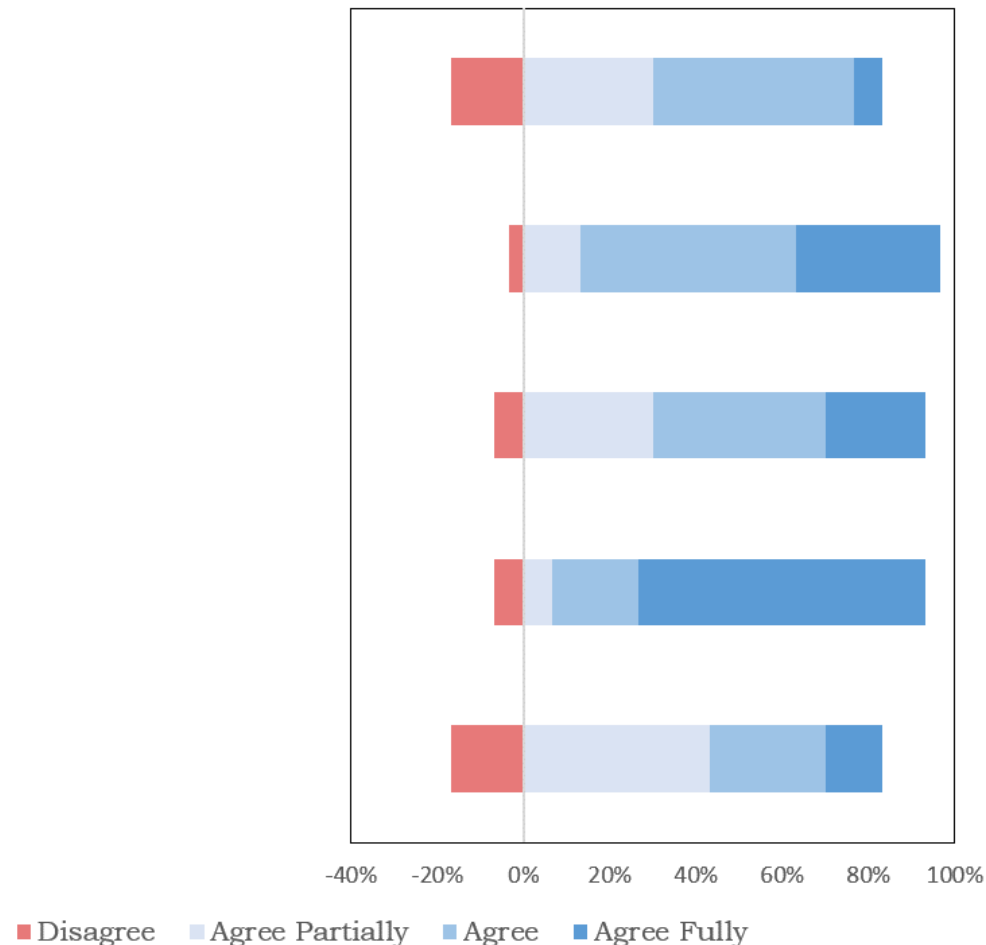

# Results – Open questions about the remote lab



Connection, server or  
login issues



Potential of the  
equipment

Access anytime, from  
anywhere

No fear of damaging

Nothing negative to  
highlight

# Results – Tasks and Exams

Table 1: Correlations between the number  $N$  of VISIR logs and grades

|                | Grades     |             |       |       |
|----------------|------------|-------------|-------|-------|
|                | Lab Report | Other Tasks | Exams | Final |
| $N$ VISIR logs |            |             |       |       |

Spearman's  $r_{sp}$  and Pearson's  $r_p$  correlation coefficients.

# Results – Tasks and Exams

Table 2: Correlations between grades of tasks and exams and final grades

| Grades | Lab Report | Other Tasks |
|--------|------------|-------------|
| Exams  |            |             |
| Final  |            |             |

Spearman's  $r_{sp}$  and Pearson's  $r_p$  correlation coefficients.

# Conclusions

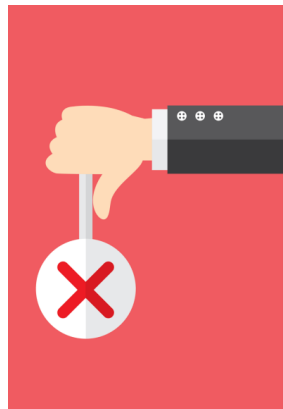

We need more data

Teacher support is critical



Positive impacted students' academic performance

Students felt more motivated to collaborate and learn statistics

Teacher felt more motivated

Replicable

Adequate for remote learning

Thank you!

Marcelo Zannin

m.zannin@ufsc.br

Natércia Lima

nmm@isep.ipp.pt

Carla M.A. Pinto

cap@isep.ipp.pt